

VENT
DAMPER
PLUG

IGNITION DIAGRAM

DCG3 Series Commercial Gas Spare Parts

Repair Parts Illustration

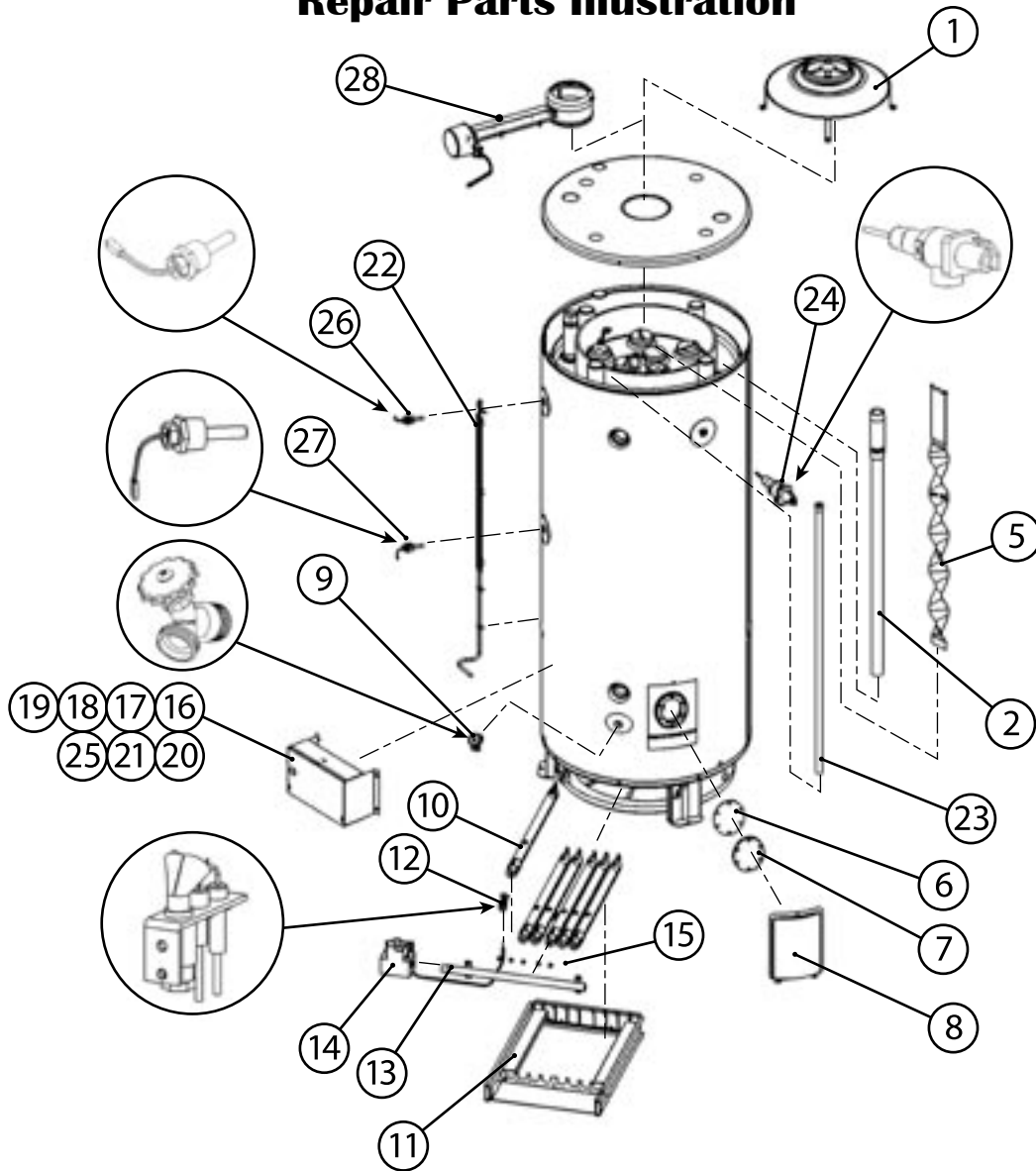

Repair Parts List

No.	Part Name and Description	No.	Part Name and Description
1	Drafthood	15	Main Burner Orifice(s)
2	Dip Tube (top)	16	Control Box Cover
3	Dip Tube (front - optional - not pictured)	17	Transformer
4	Dip Tube (back - optional - not pictured)	18	Ignition Control Module
5	Flue Baffles	19	Thermostat Board
6	Cleanout Gasket	20	ECO Reset Board
7	Cleanout Cover	21	Control Box
8	Cleanout Cover Jacket	22	Wiring Harness
9	Drain Valve	23	Anode Rod(s)
10	Main Burner Tube(s)	24	T&P Valve
11	Burner Tray	25	Temperature Control Potentiometer
12	Pilot Burner Assembly	26	Upper Temperature Sensor / ECO
13	Main Burner Manifold	27	Lower Temperature Sensor
14	Gas Valve	28	Flue Damper

		Model Number									
		DCG3-80T199		DCG3-100T199		DCG3-100T270		DCG3-75T125		DCG3-80T399	
No.	Part Name and Description	QTY	Part #	QTY	Part #	QTY	Part #	QTY	Part #	QTY	Part #
1	Drafthood	1	2710032	1	2710028	1	2710032	1	2710034	1	2710036
1a	Reducer (C-Vent) 7" to 6"	1	2710031			1	2710031				
2	Diptube (Top)	1	4710875	1	4710851	1	4710851	1	4710876		
3	Diptube (Front) (Optional not pictured)	1	4710889	1	4710852	1	4710852	1	4710886	1	4710887
4	Diptube (Back) (Optional not pictured)	1	4710889	1	4710853	1	4710853	1	4710886	1	4710888
6	Clean Out Gasket	1	4410156	1	4410156	1	4410156	1	4410156	1	4410156
7	Clean Out Cover	1	4710854	1	4710854	1	4710854	1	4710854	1	4710854
9	Drain Valve	1	4310172	1	4310172	1	4310172	1	4310172	1	4310172
10-15	Burner Assy - NAT	1	3010235	1	3010221	1	3010224	1	3010238	1	3010241
10-15	Burner Assy - NOX	1	3010236	1	3010222	1	3010225	1	3010239	1	3010242
10-15	Burner Assy - LPG	1	3010237	1	3010223	1	3010226	1	3010240	1	3010243
10	Main Burner Tube(s)(NAT/LPG)	5	3110032	5	3110032	7	3110032	3	3110032	9	3110036
10	Main Burner Tube(s)(NOx)	5	3110033	5	3110033	7	3110033	3	3110033	9	3110037
10	Burner Tube w/Pilot Bracket (NAT/LPG)	1	3110034	1	3110034	1	3110034	1	3110034	1	3110038
10	Burner Tube w/Pilot Bracket (NOx)	1	3110035	1	3110035	1	3110035	1	3110035	1	3110039
12	Pilot Burner Assembly(natural)	1	3210569	1	3210569	1	3210569	1	3210569	1	3210569
12	Pilot Burner Assembly(propane)	1	3210570	1	3210570	1	3210570	1	3210570	1	3210570
13	Main Burner Manifold	1	3710084	1	3710084	1	3710086	1	3710088	1	3710090
14	Gas Valve (NAT)	1	3210571	1	3210571	1	3210571	1	3210571	1	3210593
14	Gas Valve (LPG)	1	3210612	1	3210612	1	3210612	1	3210612	1	3210594
15	Main Burner Orifice(s) (NAT/NOx)	6	3600376	6	3600376	8	3600376	4	3600383	10	3600382
15	Main Burner Orifice(s) (LPG)	6	3600377	6	3600377	8	3600377	4	3600380	10	3600385
16	Control Box Cover	1	2010864	1	2010864	1	2010864	1	2010864	1	2010864
17	Transformer	1	4210282	1	4210282	1	4210282	1	4210282	1	4210282
18	Ignition Control Module	1	3210567	1	3210567	1	3210567	1	3210567	1	3210567
19	Thermostat board	1	3201049	1	3201049	1	3201049	1	3201049	1	3201049
20	ECO Reset Board (Lockout Control)	1	3210568	1	3210568	1	3210568	1	3210568	1	3210568
21	Control Box	1	2010865	1	2010865	1	2010865	1	2010865	1	2010865
22	Wiring Harness	1	4210281	1	4210281	1	4210281	1	4210281	1	4210281
24	T&P Valve	1	4300021	1	4300021	1	4300111	1	4300021	1	4300111
25	Temp. Control Potentiometer	1	3201069	1	3201069	1	3201069	1	3201069	1	3201069
26	Upper Temperature Sensor/ECO	1	3210566	1	3210566	1	3210566	1	3210566	1	3210566
27	Lower Temperature Sensor	1	3210565	1	3210565	1	3210565	1	3210565	1	3210565
28	Flue Damper	1	2710029	1	2710029	1	2710030	1	2710037	1	2710038
N/A	Wire Harness (Secondary)	1	4210283	1	4210283	1	4210283	1	4210283	1	4210283

When ordering repair parts, always give the following information:

- Model, serial and product number
- Parts Item number
- Type of gas
- Parts description

**Order Entry and Sales**

500 Princeton Road (FedEx, UPS)
Johnson City, TN 37601-2030
P.O. Box 4056 (Mailing)
Johnson City, TN 37602-4056
Hours of Operation:
Monday-Friday 8:00 a.m. - 6:30 p.m. EST
(800) 937-1037 Fax: (800) 581-7224

Warranty and Service Support

500 Princeton Road (FedEx, UPS)
Johnson City, TN 37601-2030
P.O. Box 1597 (Mailing)
Johnson City, TN 37605

Residential Product Service and Support

Hours of Operation:
Monday-Friday 8:00 a.m. - 8:00 p.m. EST
Saturday 9:00 a.m. - 6:00 p.m. EST
(800) 999-9515 Fax: (800) 999-5210

Commercial Product Service and Support

Hours of Operation:
Monday-Friday 8:00 a.m. - 8:00 p.m. EST
Saturday 9:00 a.m. - 6:00 p.m. EST
(800) 456-9805 Fax: (800) 999-5210

Warranty Claims

Hours of Operation:
Monday-Friday 8:00 a.m. - 5:00 p.m. EST
(800) 999-5052 Fax: (800) 999-5210

General Information

Hours of Operation:
Monday-Friday 8:00 a.m. - 5:00 p.m. EST
(423) 283-8000 Fax: (423) 283-8050

International Sales

Hours of Operation:
Monday-Friday 8:00 a.m. - 5:00 p.m. EST
(423) 283-8062 or (423) 283-8176
Fax: (423) 283-8137

Literature Fulfillment/Promotional Items

Hours of Operation:
Monday-Friday 8:00 a.m. - 5:00 p.m. EST
(423) 232-2477 Fax: (423) 232-2480

Credit/Collections

Hours of Operation:
Monday-Friday 8:00 a.m. - 5:00 p.m. EST
(423) 434-1681 Fax: (423) 975-2457

Visit our Website at
www.americanwaterheater.com