

Controller

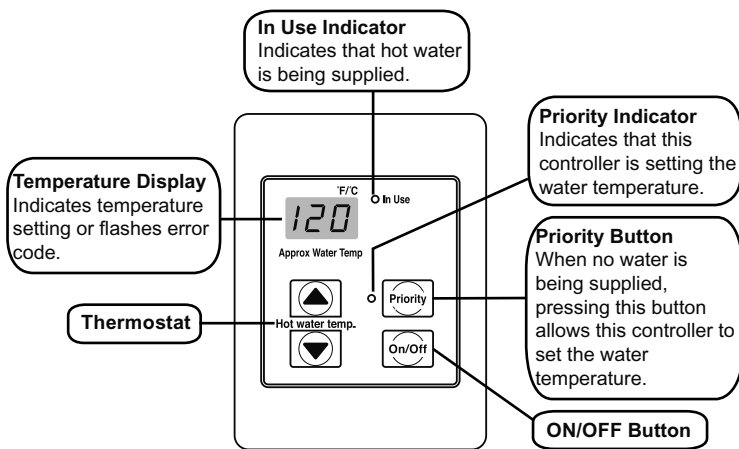

Diagnostic Use of the Controller

- To display error codes, press the ON/OFF button followed by the ▲ thermostat button to cycle through the error codes.
- To display the water flow through the water heater, press the ▲ thermostat button (hold for 2 seconds) and then press the ON/OFF button while continuing to hold the ▲ thermostat button.
- To display the outlet water temperature, press the ▼ thermostat button (hold for 2 seconds) and then press the ON/OFF button while continuing to hold the ▼ thermostat button.

To Change the Temperature Scale (°F / °C)

With the water heater turned off, press and hold the ON/OFF button until the display changes to the other temperature scale (about 5 seconds).

To Turn Off the Controller Sound (Mute)

To turn the sound off (mute), press and hold both the ▲ and ▼ thermostat buttons until a "beep" is heard (about 5 seconds).

Gas Pressure Setting

Ensure gas pressure check under Commissioning has been completed first! The regulator is electronically controlled and factory pre-set. Under normal circumstances it does not require adjustment during installation. Make adjustments only if the unit is not operating correctly and all other possible causes for incorrect operation have been eliminated.

- Turn OFF the gas supply.
- Turn OFF the 120 V power supply.
- Remove the front panel from the appliance.
- Check the gas type using the data plate on the side of the unit. If using a spare PC board, check that the gas type switches are in the correct position (dip switch 1 of SW2: ON for natural gas, NG, and OFF for propane, LPG). See dip switch settings section below. (ON is towards the right and OFF is towards the left.)
- Attach the pressure gauge to the burner test point, located on the gas control (Fig. 2).
- Turn ON the gas supply.
- Turn ON the 120 V power supply.
- If a controller is installed, turn the unit ON with the controller. Select the maximum delivery temperature and open all available hot water taps at full.
- Set the unit to 'Forced Low' combustion by setting No. 7 dip switch of the SW1 set to ON (Fig. 3).
- Check the burner test point pressure.
- Remove the rubber access plug and adjust the regulator screw on the modulating valve (Fig. 4) as required in Table 1. Replace the rubber access plug.
- Set the unit to 'Forced High' combustion by setting both No. 7 and No. 8 dip switches of the SW1 set to ON (Fig. 5). Ensure maximum water flow.
- Check the burner test point pressure.
- Adjust the high pressure potentiometer (POT) on the PC board as required to the pressure shown in Table 1.
- Return the unit to normal operation by setting dip switches 7 and 8 of the SW1 set back to OFF (Fig. 6). Close all water taps.
- Turn OFF the gas supply and 120 V power supply.
- Remove the pressure gauge and install sealing screw.
- Turn ON the gas supply and 120 V power supply.
- Operate the unit and check for gas leaks at the test point.
- Install the front panel.

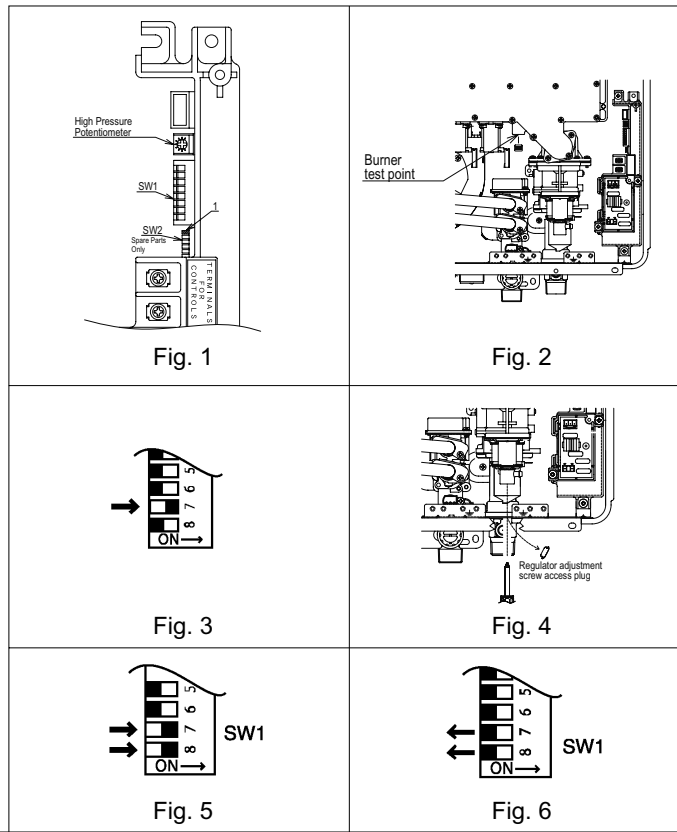

Gas Pressure Setting

NOTE: For additional installation and commissioning information refer to the Operation and Installation Manual.

WARNING

This appliance must be installed, serviced and removed by a trained and qualified person. During pressure testing of the consumer piping, ensure gas valve is turned off before unit is shut off. Failure to do so may result in serious injury to yourself or damage to the unit.

APPLIANCE OPERATING PRESSURES

Table 1

	Water Inlet Max.	Gas Inlet Min./Max.		Forced Low		Forced High	
		NAT.G	LPG	NAT.G	LPG	NAT.G	LPG
705(Outdoor)	150 PSI	5"W.C. /10.5"W.C.	8"W.C. /13.5"W.C.	0.65"W.C.	0.80"W.C.	2.8"W.C.	3.8"W.C.
705(Outdoor-ASME)							

Commissioning

With all gas appliances in operation at maximum gas rate, the flowing inlet pressure at the incoming test point on the Rinnai water heater should read 5" W.C. - 10.5" W.C. on natural gas and 8" W.C. - 13.5" W.C. on propane gas. If the pressure is lower, the gas supply is inadequate and the unit will not operate to specification. Check the gas meter regulator and pipework for correct operation/sizing and correct as required.

Troubleshooting

Important Safety Notes

There are a number of (live) tests that are required when fault finding this product. Extreme care should be used at all times to avoid contact with energized components inside the water heater. Only trained and qualified service technicians should attempt to repair this product. Before checking for resistance readings, disconnect the power source to the unit and isolate the item from the circuit (unplug it).

(SV1, SV2, SV3 and POV) Gas valve and Modulating solenoids: (Set meter above 2K)

Wire color	Voltage	Resistance	Connector #	Pin #'s
(Main) Pink - Black	11 ~ 13 VDC	24 ~ 28 ohms	H3	6 - 7
(SV1) Black - Red	11 ~ 13 VDC	37 ~ 43 ohms	H4	5 - 6
(SV2) Black - Orange	11 ~ 13 VDC	37 ~ 43 ohms	H5	4 - 6
(SV3) Black - Yellow	11 ~ 13 VDC	37 ~ 43 ohms	H6	3 - 6
(POV) Orange - Orange	2 ~ 15 VDC	67 ~ 81 ohms	H2	9 - 10

(M) Water Flow Control Device Servo or Geared Motor:

Wire color	Voltage	Resistance	Connector #	Pin #'s
Red - Blue	11 ~ 13 VDC	22 ~ 28 ohms	F5	9 - 10
Grey - Brown	4 ~ 6 VDC	N/A	F5	5 - 7
Grey - Yellow	N/A	N/A	F5	5 - 8

NOTE: The grey wire listed above turns to black at F connector on the PCB.

(QS) Water Flow Sensor:

Wire color	Voltage	Resistance	Connector #	Pin #'s
Black - Red	11 ~ 13 VDC	5.5 ~ 6.2 K ohms	F2	1 - 3
Yellow - Black	4 ~ 7 VDC	1 ~ 1.4 Mega ohms	F2	2 - 3

By-pass Flow Control:

Wire color	Voltage	Resistance	Connector #	Pin #'s
Brown - White	2 ~ 6 VDC	15 ~ 35 ohms	G1	1 - 5
Orange - White	(Unit in operating mode)		G1	2 - 5
Yellow - White			G1	3 - 5
Red-White - Ground			G1	4 - 5

(IG) Ignition System:

Wire color	Voltage	Resistance	Connector #	Pin #'s
Grey - Grey	90 ~ 110 VAC	N/A	C1	1 - 2

(FM) Combustion Fan Motor:

Wire color	Voltage	Resistance	Connector #	Pin #'s
Red - Black	6 ~ 45 VDC	N/A	E1	1 - 2
White - Black	5 ~ 10 VDC	9.2 ~ 9.4 K ohms	E1	2 - 4
Yellow - Black	11 ~ 13 VDC	3.5 ~ 3.9 K ohms	E1	2 - 3

Set your meter to the hertz scale. Reading across the white and black wires at terminals 2 and 4 you should read between 60 and 420 hertz.

Thermal Fuse / Overheat Switch:

Wire color	Voltage	Resistance	Connector #	Pin #'s
Red - White	11 ~ 13 VDC	Below 1 ohms	F6	H1 - H12

Flame Rod:

Place one lead of your meter to the flame rod and the other to ground. With the unit running you should read between 5-150 VAC. Set your meter to the μ amp scale and series your meter in line with the flame rod. You should read 1 μ amp or greater for proper flame circuit. In the event of low flame circuit remove the flame rod and check for carbon or damage.

Heat Exchanger and Outgoing Water Temperature Thermistors:

Check all thermistors by inserting meter leads into each end of the thermistor plug. Set your meter to the 20 K scale and read resistance. Applying heat to the thermistor bulb should decrease the resistance. Applying ice to the thermistor bulb should increase the resistance. See below for examples of typical temperatures and resistance readings.

Example:	59°F = 11.4 ~ 14K	140°F = 2.2 ~ 2.7K
	86°F = 6.4 ~ 7.8K	221°F = 0.6 ~ 0.8K
	113°F = 3.6 ~ 4.5K	

Outgoing Water Thermistor:

Wire color	Voltage	Resistance	Connector #	Pin #'s
White - White	N/A	See example above	F4	3 - 4

Heat Exchanger Temperature Thermistor:

Wire color	Voltage	Resistance	Connector #	Pin #'s
Pink - White	N/A	See example above	F3	3 - 11

Surge Protector:

Wire color	Voltage	Resistance	Connector #	Pin #'s
Black - White	108 ~ 132 VAC	N/A	D2	1 - 3
Black - White	108 ~ 132 VAC	N/A	D1	1 - 3

With the power off you can check the continuity through the surge protector. Place a meter lead on the top pin #1 of the surge protector and pin #3 on the bottom of the surge protector. Check across the top pin #3 and bottom pin #1. If you read continuity across these two points then the surge protector is good. If you do not get continuity then replace the surge protector.

Remote Controls:

Terminals	Voltage	Resistance	Connector #	Pin #'s
Terminals B1	10 ~ 13 VDC	1.5 ~ 3.0 K ohms	B	1 - 3

Frost Protection:

This unit has frost protection heaters mounted at different points to protect the water heater from freezing. The heaters located on the hot water outlet line should have a resistance reading of 180-207 ohms through each of these heaters. The heater located on the heat exchanger piping should have a resistance reading of 156-180 ohms and the one located in the water flow sensor valve should have a resistance reading 24-28 ohms.

Amp Fuses:

This unit has one inline (3) amp glass fuses. Remove the fuse and check continuity through it. If you have continuity through the fuse then it is good. Otherwise the fuse is blown and must be replaced.

Dip Switches Settings

Adjust switches 2 and 3 in the bank of 8 depending on your altitude according to the table below.

The original PC boards on the water heaters do not have the bank of 6 dip switches. Only spare PC boards have this bank.



WARNING

DO NOT adjust the other dip switches unless specifically instructed to do so. Incorrect Dip Switch Settings can cause the water heater to operate in an unsafe condition and may damage the water heater and void the warranty.

SW No.	Setting	Altitude Range
2	Off	Level 0 (0-2000 ft) (0-610 m)
3	Off	Level 1 (2001-5200 ft) (610-1585 m)
	On	Level 2 (5201-7700 ft) (1585-2347 m)
	On	Level 3 (7701-10200 ft) (2347-3109 m)

Error Codes

02 No burner operation during freeze protection mode <ul style="list-style-type: none"> Service Call 	16 Over Temperature Warning <ul style="list-style-type: none"> Check for restrictions in air flow around unit and vent terminal. Check for low water flow in a circulating system causing short-cycling. Check for foreign materials in combustion chamber and/or exhaust piping. Check for clogged heat exchanger.
03 Power interruption during Bath fill (Water will not flow when power returns) <ul style="list-style-type: none"> Turn off all hot water taps. Press ON/OFF twice. 	32 Outgoing Water Temperature Sensor Fault <ul style="list-style-type: none"> Check sensor wiring for damage. Measure resistance of sensor. Clean sensor of scale build up. Replace sensor.
10 Air Supply or Exhaust Blockage <ul style="list-style-type: none"> Ensure approved venting materials are being used. Check that nothing is blocking the flue inlet or exhaust. Check all vent components for proper connections. Ensure vent length is within limits. Ensure condensation collar was installed correctly. Verify dip switches are set properly. Check fan for blockage. 	33 Heat Exchanger Outgoing Temperature Sensor Fault <ul style="list-style-type: none"> Check sensor wiring for damage. Measure resistance of sensor. Clean sensor of scale build up. Replace sensor.
11 No Ignition <ul style="list-style-type: none"> Check that the gas is turned on at the water heater, gas meter, or cylinder. Ensure gas type and pressure is correct. Ensure gas line, meter, and/or regulator is sized properly. Bleed all air from gas lines. Verify dip switches are set properly. Ensure appliance is properly grounded. Disconnect multi-unit connections to isolate the problem. Ensure igniter is operational. Check igniter wiring harness for damage. Check gas solenoid valves for open or short circuits. Remove burner cover and ensure all burners are properly seated. Remove burner plate and inspect burner surface for condensation or debris. 	34 Combustion Air Temperature Sensor Fault <ul style="list-style-type: none"> Check for restrictions in air flow around unit and vent terminal. Check sensor wiring for damage. Measure resistance of sensor. Clean sensor of scale build up. Ensure fan blade is tight on motor shaft and is in good condition. Replace sensor.
12 Flame Failure <ul style="list-style-type: none"> Check that the gas is turned on at the water heater and gas meter. Check for obstructions in the flue outlet. Ensure gas line, meter, and/or regulator is sized properly. Ensure gas type and pressure is correct. Bleed all air from gas lines. Ensure proper venting material is installed. Ensure condensation collar was installed properly. Ensure vent length is within limits. Verify dip switches are set properly. Ensure appliance is properly grounded. Disconnect keypad. Disconnect multi-unit connections to isolate the problem. Check power supply for loose connections. Check power supply for proper voltage and voltage drops. Ensure flame rod wire is connected. Check flame rod for carbon build-up. Disconnect and re-connect all wiring harnesses on unit and PC board. Check all components for electrical short. Check gas solenoid valves for open or short circuits. Remove burner plate and inspect burner surface for condensation or debris. 	52 Modulating Solenoid Valve Signal Abnormal <ul style="list-style-type: none"> Check modulating gas solenoid valve wiring harness for loose or damage terminals. Measure resistance of valve coil.
14 Thermal Fuse <ul style="list-style-type: none"> Check gas type of unit and ensure it matches gas type being used. Check for restrictions in air flow around unit and vent terminal. Check for low water flow in a circulating system causing short-cycling. Ensure dip switches are set to the proper position. Check for foreign materials in combustion chamber and/or exhaust piping. Check heat exchanger for cracks and/or separations. Check heat exchanger surface for hot spots which indicate blockage due to scale build up. Refer to instructions in manual for flushing heat exchanger. Measure resistance of safety circuit. Ensure high fire and low fire manifold pressure is correct. Check for improper conversion of product. 	61 Combustion Fan Failure <ul style="list-style-type: none"> Ensure fan will turn freely. Check wiring harness to motor for damaged and/or loose connections. Measure resistance of motor winding.
16 Over Temperature Warning <ul style="list-style-type: none"> Check for restrictions in air flow around unit and vent terminal. Check for low water flow in a circulating system causing short-cycling. Check for foreign materials in combustion chamber and/or exhaust piping. Check for clogged heat exchanger. 	65 Water Flow Servo Fault (does not stop flow properly) <ul style="list-style-type: none"> If blank screen is present on remote control then the flow control has shorted out. Unplug flow control. If remote lights up and unit starts operating then replace flow control assembly.
03 Power interruption during Bath fill (Water will not flow when power returns) <ul style="list-style-type: none"> Turn off all hot water taps. Press ON/OFF twice. 	71 SV0, SV1, SV2, and SV3 Solenoid Valve Circuit Fault <ul style="list-style-type: none"> Check wiring harness to all solenoids for damage and/or loose connections. Measure resistance of each solenoid valve coil.
10 Air Supply or Exhaust Blockage <ul style="list-style-type: none"> Ensure approved venting materials are being used. Check that nothing is blocking the flue inlet or exhaust. Check all vent components for proper connections. Ensure vent length is within limits. Ensure condensation collar was installed correctly. Verify dip switches are set properly. Check fan for blockage. 	72 Flame Sensing Device Fault <ul style="list-style-type: none"> Ensure flame rod is touching flame when unit fires. Check all wiring to flame rod for damage. Remove flame rod and check for carbon build-up; clean with sand paper. Check inside burner chamber for any foreign material blocking flame at flame rod. Measure micro amp output of sensor circuit with flame present. Replace flame rod.
11 No Ignition <ul style="list-style-type: none"> Check that the gas is turned on at the water heater, gas meter, or cylinder. Ensure gas type and pressure is correct. Ensure gas line, meter, and/or regulator is sized properly. Bleed all air from gas lines. Ensure proper venting material is installed. Ensure condensation collar was installed properly. Ensure vent length is within limits. Verify dip switches are set properly. Ensure appliance is properly grounded. Disconnect keypad. Disconnect multi-unit connections to isolate the problem. Check power supply for loose connections. Check power supply for proper voltage and voltage drops. Ensure flame rod wire is connected. Check flame rod for carbon build-up. Disconnect and re-connect all wiring harnesses on unit and PC board. Check all components for electrical short. Check gas solenoid valves for open or short circuits. Remove burner plate and inspect burner surface for condensation or debris. 	LC Scale Build-up in Heat Exchanger (when checking maintenance code history "00" is substituted for "LC") <ul style="list-style-type: none"> Flush heat exchanger. Refer to instructions in manual. Replace heat exchanger.
12 Flame Failure <ul style="list-style-type: none"> Check that the gas is turned on at the water heater and gas meter. Check for obstructions in the flue outlet. Ensure gas line, meter, and/or regulator is sized properly. Ensure gas type and pressure is correct. Bleed all air from gas lines. Ensure proper venting material is installed. Ensure condensation collar was installed properly. Ensure vent length is within limits. Verify dip switches are set properly. Ensure appliance is properly grounded. Disconnect keypad. Disconnect multi-unit connections to isolate the problem. Check power supply for loose connections. Check power supply for proper voltage and voltage drops. Ensure flame rod wire is connected. Check flame rod for carbon build-up. Disconnect and re-connect all wiring harnesses on unit and PC board. Check all components for electrical short. Check gas solenoid valves for open or short circuits. Remove burner plate and inspect burner surface for condensation or debris. 	No Code (Nothing happens when water flow is activated.) <ul style="list-style-type: none"> Clean inlet water supply filter. On new installations ensure hot and cold water lines are not reversed. Check for bleed over. Isolate unit from building by turning off hot water line to building. Isolate the circulating system if present. Open your pressure relief valve; if unit fires, there is bleed over in your plumbing. Ensure you have at least the minimum flow rate required to fire unit. Ensure turbine spins freely. Measure the resistance of the water flow control sensor. Remote control does not light up but you have 12 VDC at the terminals for controls.

Wiring Diagram

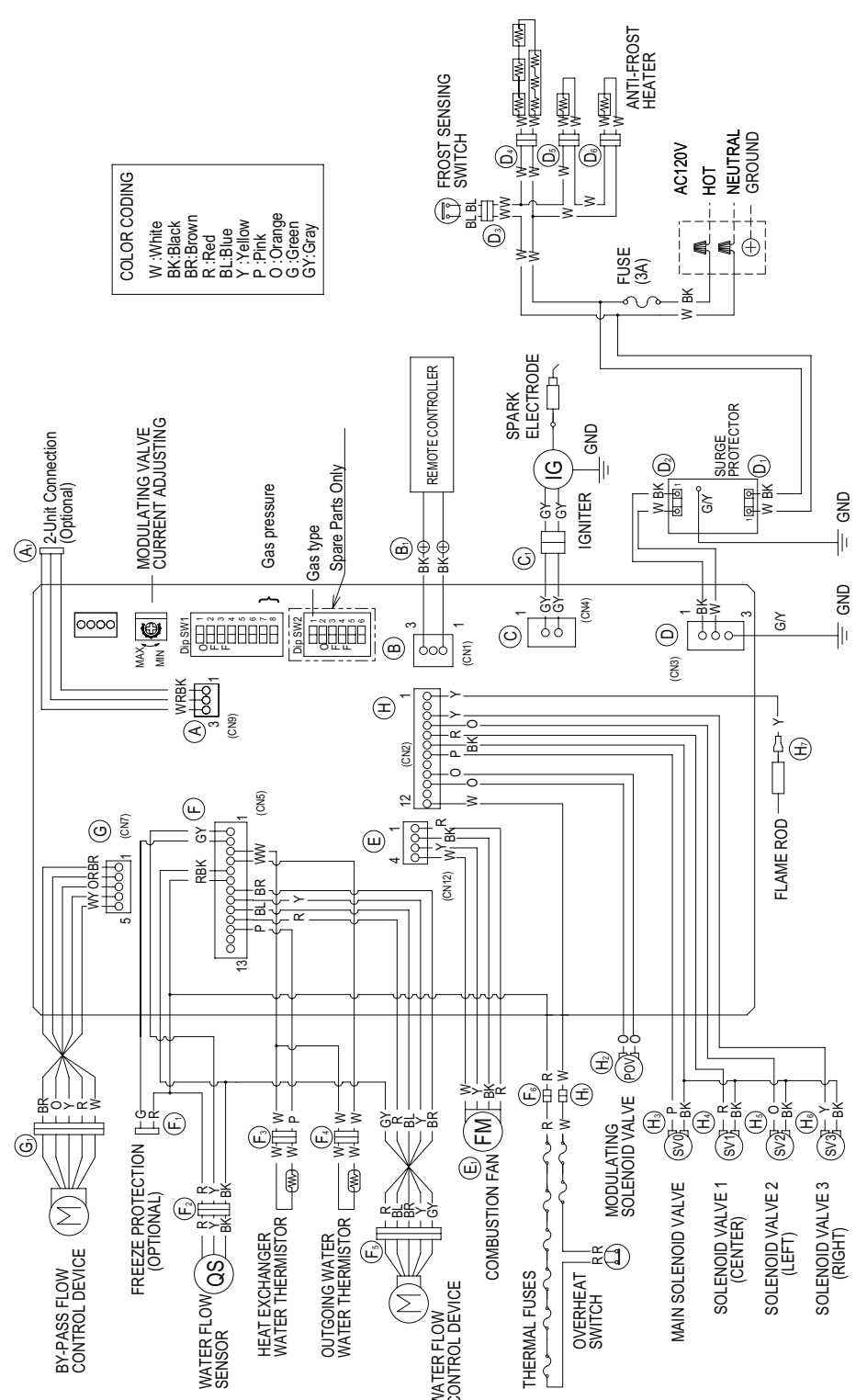

070 00012 36692 0

705 Outdoor

U273-1374(01)

