

Residential Electric Water Heater Installation Instructions and Use & Care Guide

To obtain technical, warranty or service assistance during or after the installation of this water heater, call toll free 1-800-999-9515

When calling for assistance, please have the following information ready:

1. Model number
2. 7 Digit product number
3. Serial number
4. Date of installation
5. Place of Purchase

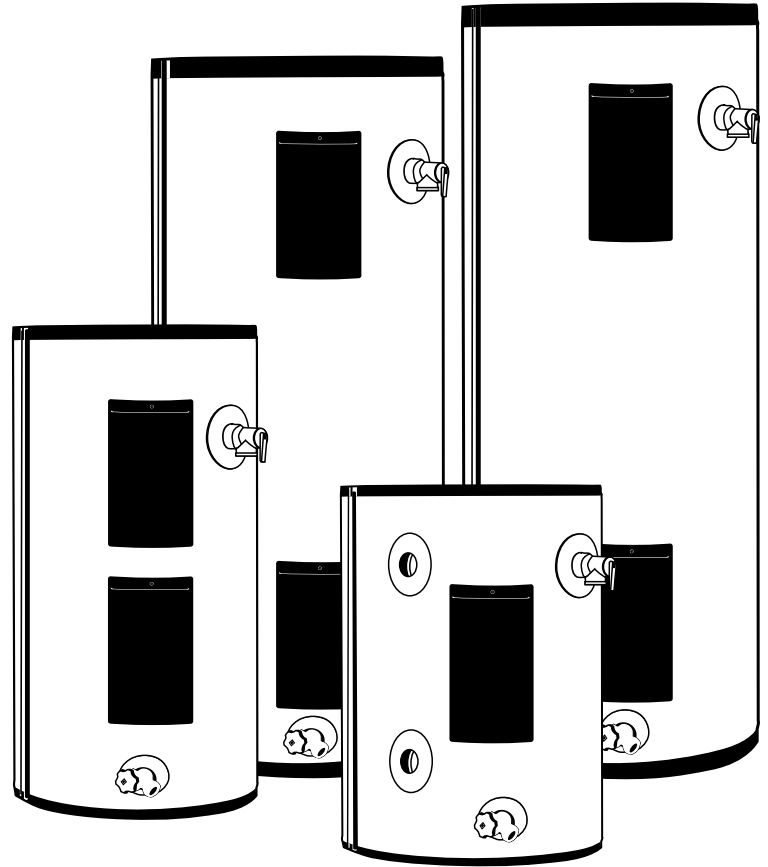

Table Of Contents

	PAGE
Water Heater Safety	2
Installing Your Electric Water Heater	3-8
Unpacking Instructions	3
Location Requirements	4
Electrical Requirements	5
Water System Piping	6
Installation Checklist	8
Operating Your Water Heater	9-11
Water Temperature Regulation	9
Adjusting the Thermostat	10
Operational Conditions	11
Maintenance of Your Water Heater	12-13
Trouble Shooting Chart	14
Repair Parts Illustration	15
Thermostat Wiring Chart and Diagram	16

Your safety and the safety of others are very important.

We have provided many important safety messages in this manual and on your appliance. Always read and obey all safety messages.



This is the safety alert symbol.

This symbol alerts you to potential hazards that can kill or hurt you and others.

All safety messages will follow the safety alert symbol and either the word "DANGER" or "WARNING." These words mean:

⚠ DANGER

You can be killed or seriously injured if you don't immediately follow instructions.

⚠ WARNING

You can be killed or seriously injured if you don't follow instructions.

All safety messages will tell you what the potential hazard is, tell you how to reduce the chance of injury, and tell you what can happen if the instructions are not followed.

Important Safety Instructions

CAUTION: Hydrogen gas is produced in a hot water system served by this heater that has not been used for a long period of time (2 weeks or more). Hydrogen is extremely flammable. To reduce the risk of injury under these conditions, it is recommended that the hot water faucet be opened for several minutes at the kitchen sink before using any electrical appliance connected to the hot water system. When hydrogen is present, there will be an unusual sound such as air escaping through the pipe as the water begins to flow. There should be no smoking or open flame near the faucet at the time it is open.

The California Safe Drinking Water and Toxic Enforcement Act requires the Governor of California to publish a list of substances known to the State of California to cause cancer, birth defects, or other reproductive harm, and requires businesses to warn of potential exposure to such substances.

Warning: This product contains a chemical known to the State of California to cause cancer, birth defects, or other reproductive harm.

This appliance can cause low-level exposure to some of the substances listed, including formaldehyde.

INSTALLING YOUR WATER HEATER

Consumer Information

This water heater should be installed in accordance with the local code authority having jurisdiction, the power company or electric utility, and this installation manual. In the absence of local code requirements, follow the regulations set forth in the latest edition of The National Electric Code, NFPA 70. This is available from the following:

National Fire Protection Agency
1 Batterymarch Park
Quincy, MA 02269

American National Standards Institute
1430 Broadway
New York, NY 10018

Check your phone listings for the local authorities having jurisdiction over your installation.

Consumer Responsibilities

This manual has been prepared to acquaint you with the installation, operation and maintenance of your electric water heater and to provide important safety information in these areas.

We urge you to read all of the instructions thoroughly before attempting the installation or operation of this water heater. This manual should be kept for future reference.

The manufacturer of this water heater will not be liable for any damages caused by failure to comply with the installation and operating instructions outlined in this manual.

If you lack the necessary skills required to properly install this water heater or you have difficulty following the directions, you should not proceed but have a qualified person perform the installation of this water heater. Massachusetts code requires this water heater to be installed in accordance with Massachusetts Plumbing and Fuel Gas Code 248 CMR section 2.00 and 5.00.

A data plate identifying your water heater can be found adjacent to the element door. When referring to your water heater always have the information listed on the data plate readily available.

Retain your original receipt as proof of purchase.

Unpacking the Water Heater



Excessive Weight Hazard

Use two or more people to move and install water heater.

Failure to do so can result in back or other injury.

Removing Packaging Materials

Important: Do not remove any permanent instructions, labels, or the data label from outside of the water heater or on the inside of panels.

- Remove exterior packaging and place installation components aside.
- Inspect all parts for damage prior to installation and start-up.
- Completely read all instructions before attempting to assemble and install this product.
- After installation, dispose of packaging material in the proper manner.

Location Requirements

Site location

Select a location near the center of the water piping system. It must be installed indoors and in a vertical position on a level surface.

The water heater should be located in an area not subject to freezing temperatures. Water heaters located in unconditioned spaces (i.e., attics, basements, etc.) May require the water piping and drain piping to be insulated to protect against freezing. The drain and controls must be easily accessible for operation and service.

Do not use this water heater in conjunction with a spa or hot tub.

Note: Local codes and requirements in your area may require the installation of your water heater be accomplished in a way that the bottom element is elevated from the floor at least 18 inches.

Important: The water heater should be located in an area where leakage of the tank or connections will not result in damage to the area adjacent to the water heater or to lower floors of the structure. Due to the normal corrosive action of the water, the tank will eventually leak after an extended period of time. It is recommended that a suitable drain pan be installed under the water heater as shown below. This pan is to protect the property from damage which may occur from normal condensate formation on the tank or leaks in the tank and pipe connections. The pan must limit the water level to a maximum depth of 2-1/2 inches and be two inches wider than the heater and piped to an adequate drain. Locate the water heater near a suitable indoor drain. Outside drains are subject to freezing temperatures which can obstruct the drain line. The piping should be at least 3/4" ID and pitched for proper drainage.

Under no circumstance will the manufacturer be held liable for any water damage in connection with this water heater.

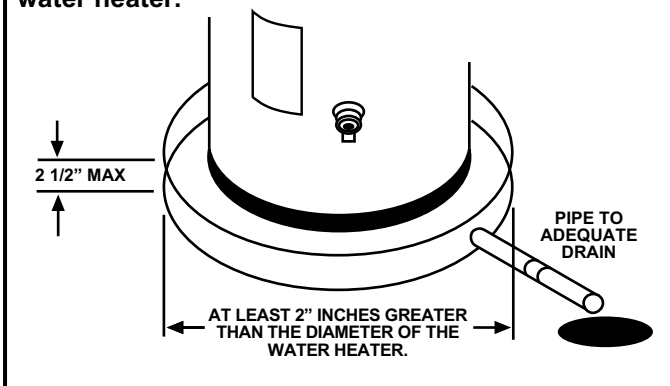

Note: The water heater shall be located so it is not subject to physical damage by moving vehicles or area flooding.

**FIGURE 1
RESIDENTIAL GARAGE
INSTALLATION**

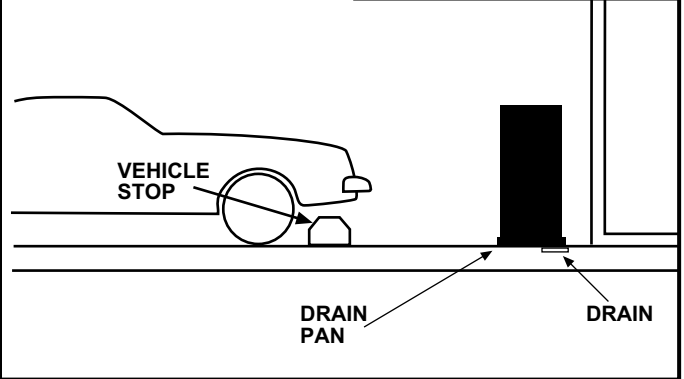

State of California

Note: The water heater must be braced, anchored, or strapped to avoid moving during an earthquake. Contact local utilities for code requirements in your area or call **1-800-999-9515** and request instructions.

Electrical Requirements

! WARNING	
	Electrical Shock Hazard
	Disconnect power before servicing.
	Replace all parts and panels before operating.
Failure to do so can result in death or electrical shock.	
! WARNING	
	Fire Hazard
	Use proper size solid copper wire.
	Use a UL approved strain relief.
	Connect ground wire to green ground screw.
	Failure to do so can result in death, fire, or electrical shock.

If you lack the necessary skills required to properly install the electrical wiring to this water heater, do not proceed but have a qualified electrician perform the installation.

When making the electrical connections, always make sure:

- The electrical supply has the proper overload fuse or breaker protection.
- Wire sizes and connections comply with all applicable codes.
- Wiring enclosed in approved conduit (if required by local codes).
- The water heater and electrical supply are properly grounded.

Figures 3, 4, and 5 are provided as reference drawings for the 120/240v 2-wire models only. Always reference the wiring diagram located on the water heater for the correct electrical connections.

When installing the electrical wiring to the water heater:

1. Be sure tank is completely filled with water before making any electrical connections. (See Figure 2)
2. Shut-off the power to the unit.
3. Loosen the screw holding the junction box cover to the top of the water heater. Set the cover aside.
4. Connect the electrical supply to the water heater in accordance with local utility requirements and codes. A standard 1/2 inch opening has been made in the junction box for conduit connections.
5. Ground the water heater by connecting a grounding wire from the electrical service ground terminal to the green grounding screw in the junction box of the water heater.

FIGURE 2
HEATING ELEMENT

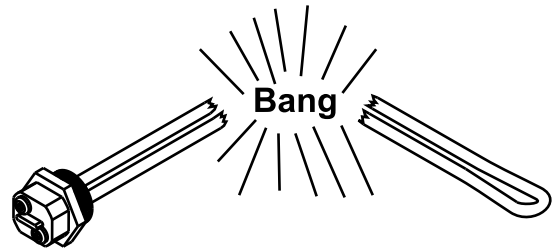

Notice: Applying electrical power to elements that are not submerged in water will destroy them. The manufacturer will not warranty any elements damaged in this manner.

FIGURE 3
120/240V 2-WIRE MODELS

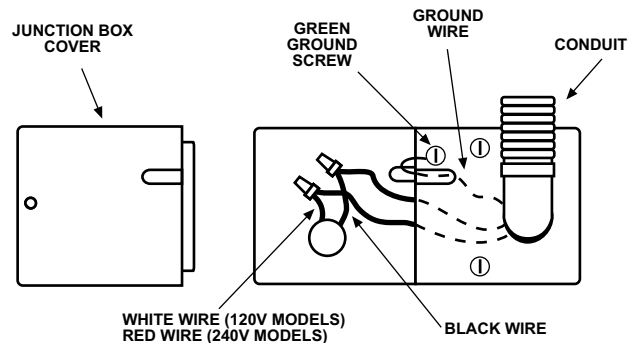

FIGURE 4
WIRING DIAGRAM
120V MODELS ONLY

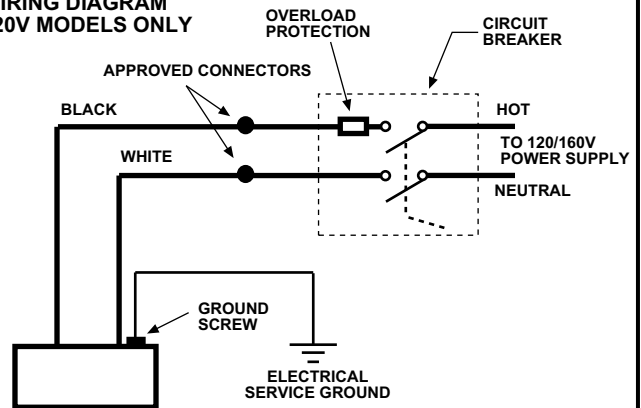
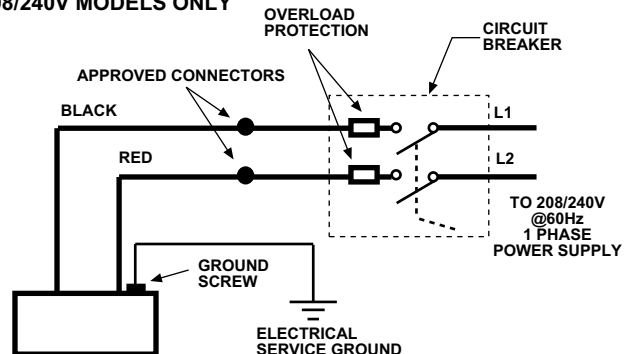

FIGURE 5
WIRING DIAGRAM
208/240V MODELS ONLY



Water System Piping

Piping Installation

Piping, fittings, and valves should be installed according to the installation drawing (Figure 6). If the indoor installation area is subject to freezing temperatures, the water piping must be protected by insulation.

Water supply pressure should not exceed 80% of the working pressure of the water heater. The working pressure is stated on the water heater's data plate. If this occurs a pressure limiting valve with a bypass may need to be installed in the cold water supply line. This should be placed on the supply to the entire house in order to maintain equal hot and cold water pressures.

Important: Heat cannot be applied to the water fittings on the heater as they may contain nonmetallic parts. If solder connections are used, solder the pipe to the adapter before attaching the adapter to the hot and cold water fittings.

Important: Always use a good grade of joint compound and be certain that all fittings are drawn up tight.

1. Install the water piping and fittings as shown in the Figure 6. Connect the cold water supply (3/4 NPT) to the fitting marked "C". Connect the hot water supply (3/4 NPT) to the fitting marked "H".

Important: Some models may contain energy saving heat traps to prevent the circulation of hot water within the pipes. Do not remove these inserts.

2. The installation of unions in both the hot and cold water supply lines are recommended for ease of removing the water heater for service or replacement.
3. The manufacturer of this water heater recommends installing a tempering valve in the domestic hot water line as shown in Figures 7 and 8. These valves reduce the point-of-use temperature of the hot water by mixing cold and hot water and are readily available. Contact a licensed plumber or the local plumbing authority.
4. If installing the water heater in a closed water system, install a relief valve or expansion tank in the cold water line as specified under "Closed System/Thermal Expansion".
5. Install a shut off valve in the cold water inlet line. It should be located close to the water heater and be easily accessible. Know the location of this valve and how to shut off the water to the heater.
6. Install a temperature and pressure relief valve and discharge line in the opening marked "T & P RELIEF VALVE". Install as specified under "Temperature and Pressure Relief Valve."
7. After piping has been properly connected to the water heater, open the nearest hot water faucet and allow the tank to completely fill with water. To purge the lines of any excess air and sediment, keep the hot water faucet open for 3 minutes after a constant flow of water is obtained. Close the faucet and check all connections for leaks.

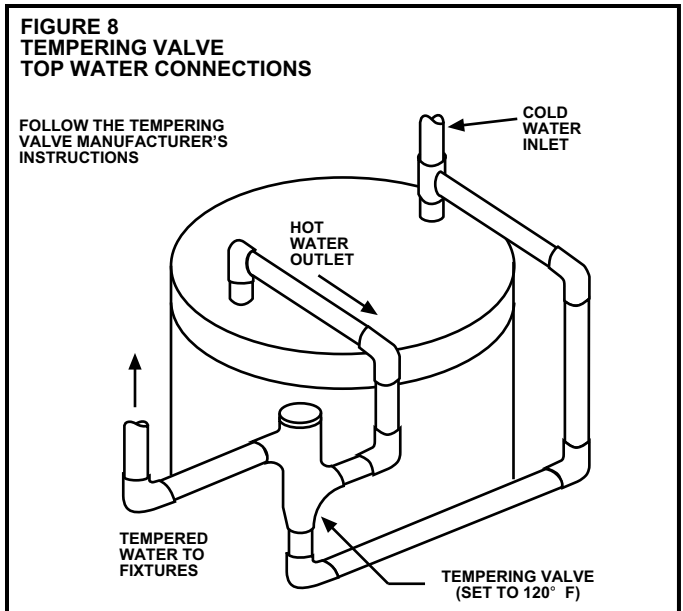
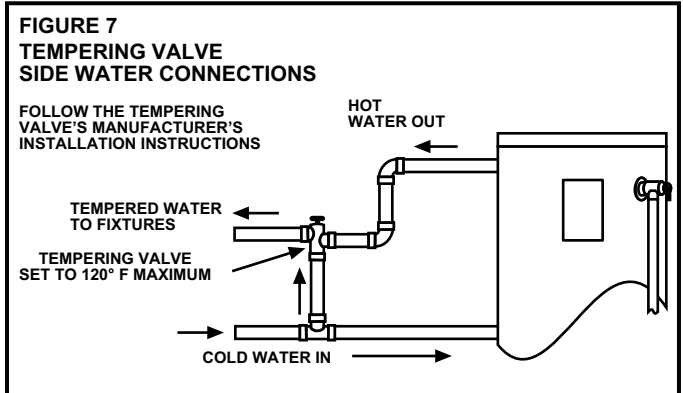
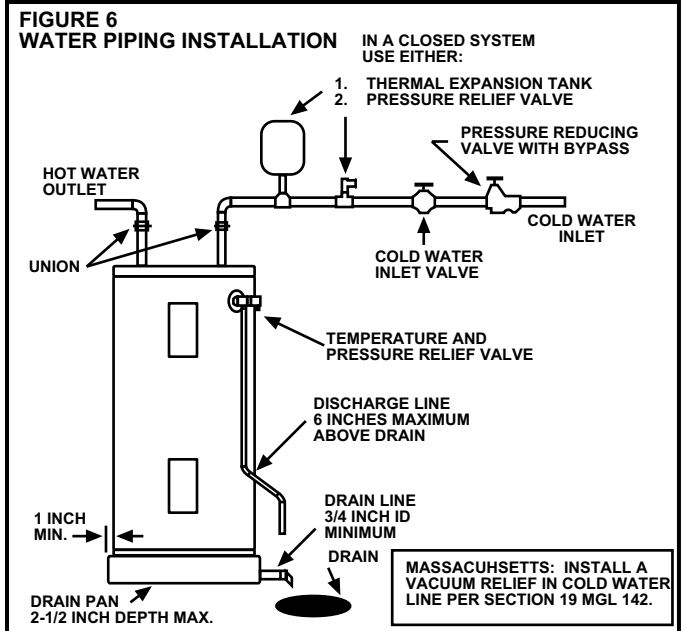

Please note the following:

DO NOT install this water heater with iron piping. The system should be installed only with new piping that is suitable for potable (drinkable) water such as copper, CPVC, or polybutylene. **DO NOT** use PVC water piping.

DO NOT use any pumps, valves, or fittings that are not compatible with potable water.

DO NOT use valves that may cause excessive restriction to water flow. Use full flow ball or gate valves only.

DO NOT use 50/50 tin-lead solder (or any lead based solder) in potable water lines. Use 95/5 tin-antimony or other equivalent material.

DO NOT tamper with the thermostat, heater elements, electrical connections, or temperature and pressure relief valve. Tampering voids all warranties. Only qualified technicians should service these components.

DO NOT use with piping that has been treated with chromate's, boiler seal, or other chemicals.

DO NOT add any chemicals to the system piping which will contaminate the potable water supply.

Closed System/Thermal Expansion

Periodic discharge of the temperature and pressure relief valve may be due to thermal expansion in a closed water supply system. The water utility supply meter may contain a check valve, backflow preventer or water pressure reducing valve. This will create a closed water system. During the heating cycle of the water heater, the water expands causing pressure inside the water heater to increase. This may cause the temperature and pressure relief valve to discharge small quantities of hot water. To prevent this from happening, there are two recommendations:

1. Install a diaphragm-type expansion tank that is suitable for potable water on the cold water supply line. The expansion tank must have a minimum capacity of 1.5 U.S. gallons for every 50 gallons of stored water.
2. Install a 125 PSI pressure relief valve in the cold water supply line. Make sure the discharge of this valve is directed to an open drain and protected from freezing.

Contact the local water supplier or plumbing inspector for information on how to control this situation. **Do not plug the temperature and pressure relief valve.**

Temperature and Pressure Relief Valve

! WARNING



Explosion Hazard

If the temperature and pressure relief valve is dripping or leaking, have a licensed plumber repair it.

Do not plug valve.

Do not remove valve.

Failure to follow these instructions can result in death, or explosion.

FIGURE 9
TEMPERATURE AND PRESSURE
RELIEF VALVE INSTALLATION

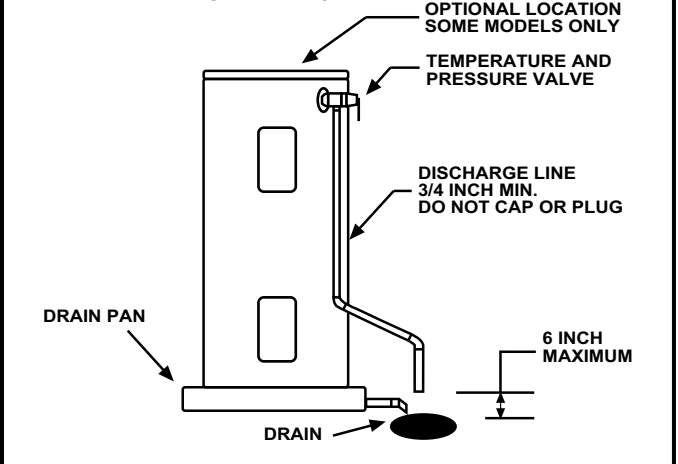

For protection against excessive pressures and temperatures, a temperature and pressure relief valve must be installed in the opening marked "T & P RELIEF VALVE" (See Figure 9).

Caution: To reduce the risk of excessive pressures and temperatures in this water heater, install temperature and pressure relief protective equipment required by local codes, but no less than a combination temperature and pressure relief valve certified by a nationally recognized testing laboratory that maintains periodic inspection of the production of listed equipment or materials, as meeting the requirements for Relief Valves and Automatic Shutoff Devices for Hot Water Supply Systems, ANSI Z21.22 - 1986. This valve must be marked with the maximum set pressure not to exceed the marked maximum working pressure of the water heater. Install the valve into an opening provided and marked for this purpose in the water heater, and orient it or provide tubing so that any discharge from the valve exits only within 6 inches above, or at any distance below, the structural floor, and does not contact any live electrical part. The discharge opening must not be blocked or reduced in size under any circumstance.

Important: Only a new temperature and pressure relief valve should be used with your water heater. Do not use an old or existing valve as it may be damaged or not adequate for the working pressure of the new water heater. Do not place any valve between the relief valve and the tank.

The Temperature & Pressure Relief Valve:

- Must not be in contact with any electrical part.
- Must be connected to an adequate discharge line.
- Must not be rated higher than the working pressure shown on the data plate of the water heater.

The Discharge Line:

- Must not be smaller than the pipe size of the relief valve or have any reducing coupling installed in the discharge line.
- Must not be capped, blocked, plugged or contain any valve between the relief valve and the end of the discharge line.
- Must terminate a maximum of 6 inches above a floor drain or external to the building.
- Must be capable of withstanding 250°F (121°C) without distortion.
- Must be installed to allow complete drainage of both the valve and discharge line.

Solar Installation

If this water heater is used as a solar storage heater or as a backup for the solar system, the water supply temperatures to the water heater tank may be in excess of 120°F. A tempering valve or other temperature limiting valve must be installed in the water supply line to limit the supply temperature to 120°F.

Note: Solar water heating systems can often supply water with temperatures exceeding 180°F and may result in water heater malfunction.

Installation Check List

Water Heater Location

- Centrally located with the water piping system.
- Located indoors and in a vertical position. Protected from freezing temperatures.
- Provisions made to protect the area from water damage. Drain pan installed and piped to an adequate drain.
- Sufficient room to service the water heater.

Water System Piping

- Temperature and pressure relief valve properly installed with a discharge line run to an open drain and protected from freezing.
- All piping properly installed and free of leaks.
- Heater completely filled with water. (See Figure 2)
- Closed system pressure buildup precautions installed.
- Tempering valve installed per manufacturer's instructions.

Electrical Connections

- Wiring and connections comply with all applicable codes.
- Water heater and electrical supply are properly grounded.
- Proper overload fuse or circuit breaker protection installed.

OPERATING YOUR WATER HEATER

Before operating the water heater, perform the following:

1. Make sure the water heater has been properly installed.
2. Completely fill the tank with water. (See Figure 2)
3. Apply power to the water heater only after the tank is completely filled with water.
4. Carefully read and understand the "Water Temperature Regulation" section of this manual.
5. Adjust the thermostat to the desired temperature setting as directed under "Adjusting the Thermostat/High Limit Control".

Important: Do not attempt to operate this water heater if the thermostat(s), or surrounding insulation has been exposed to water in any way. Immediately call a qualified service technician to inspect the water heater and replace any thermostat or insulation that has been exposed to water. Do not attempt to repair these parts. Water heaters subjected to flood conditions or any time the thermostat(s) have been submerged in water require replacement of the entire water heater.

Safety Shut-off

This water heater is designed to automatically shut-off in the event that the water temperature exceeds 170°F (77°C). A high limit control switch is used to shut off the power to the elements if the water temperature exceeds 170°F (77°C). The high limit control can be reset by firmly pushing in the red reset button located on the thermostat. Follow the instructions under "Adjusting the Thermostat/High Limit Control" to properly reset the high limit control.

Water Temperature Regulation

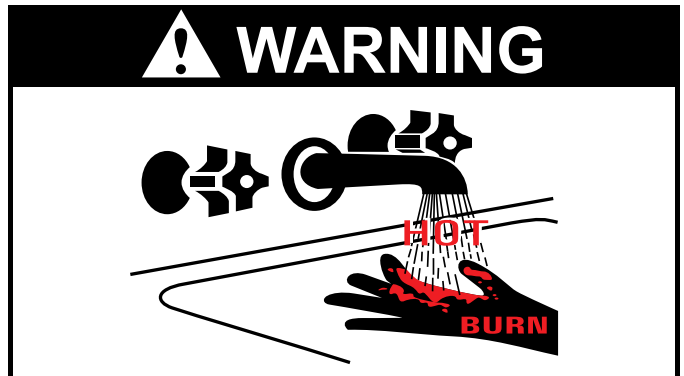

Water temperature over 125°F can cause severe burns instantly or death from scalds.

Children, disabled and elderly are at highest risk of being scalded.

See instructions manual before setting temperature at water heater.

Feel water before bathing or showering.

Temperature limiting valves are available.

The thermostat is adjusted to a temperature setting of 120°F or lower when it is shipped from the factory. Water temperature can be regulated by adjusting the thermostat to the preferred setting as shown in "Adjusting the Thermostat/High limit Control." **The preferred starting point is 120°F. There is a hot water scald potential if the thermostat is set too high.**

Important: Adjusting the thermostat past 120°F on the thermostat will increase the risk of scald injury. Hot water can produce first degree burns within:

120°F (49°C) more than 5 minutes

130°F (54°C) at 20 seconds

140°F (60°C) at 3 seconds

150°F (66°C) at 1-1/2 seconds

160°F (71°C) at less than 1 second

During low demand periods when hot water is not being used, a lower thermostat setting will reduce energy losses and may satisfy your normal hot water needs. If hot water use is expected to be more than normal, a higher thermostat setting may be required to meet the increased demand.

When leaving your home for extended periods (vacations, etc.) turn the thermostat to its lowest setting. This will maintain the water at low temperatures with minimum energy losses and prevent the tank from freezing during cold weather.

Adjusting the Thermostat/High Limit Control

This water heater is equipped with one or more adjustable temperature regulating thermostats and a manual reset high limit control. The following procedures must be performed when changing the temperature of the stored water or resetting the high limit control. **Upper and lower thermostats must be adjusted to the same temperature.**

Before attempting to adjust the thermostat, make sure you read and understand the section of "Water Temperature Regulation". Any other adjustments must be made by qualified service personnel.

1. Shut-off the power to the water heater.
2. Remove the access cover(s) and fold the insulation outward and away from the thermostat(s). Do not remove the plastic cover.
3. Using a screwdriver to adjust the thermostat pointer, set the thermostat(s) to the desired water temperature. Be sure the RED reset button (High Limit Control) is properly set: push in firmly to reset.
4. Replace the insulation. Make sure the thermostat(s) are well covered. Replace the access cover(s).
5. Apply power to the water heater.

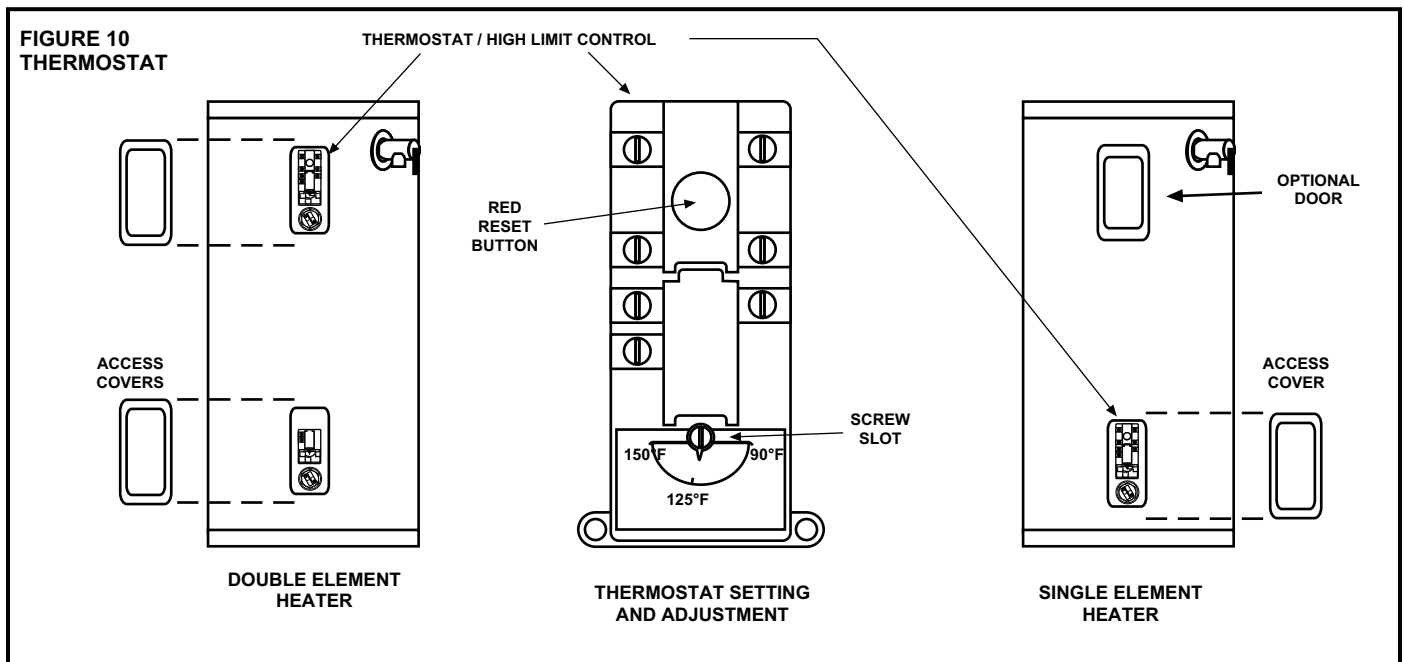

Operation Conditions

Anode Rod/Water Odor

Each water heater contains at least one anode rod, which will slowly deplete while protecting the glass-lined tank from corrosion and prolonging the life of the water heater. Certain water conditions will cause a reaction between this rod and the water. Once the anode is depleted, the tank will start to corrode, eventually developing a leak. The most common complaint associated with the anode rod is a "rotten egg smell" produced from the presence of hydrogen sulfide gas dissolved in the water. **Do not remove this rod permanently as it will void any warranties, stated or implied.** The parts list includes a special anode that can be ordered if water odor or discoloration occurs. This rod may reduce but not eliminate water odor problems. The water supply system may require special filtration equipment from a water conditioning company to successfully eliminate all water odor problems.

Artificially softened water is exceedingly corrosive because the process substitutes sodium ions for magnesium and calcium ions. The use of a water softener may decrease the life of the water heater tank.

The anode rod should be removed from the water heater tank every 3 years for inspection. If the rod is more than 50% depleted, the anode rod should be replaced.

For replacing the anode, shut-off the power to the water heater. Be sure the cold water supply to the heater is turned off. Open the hot water faucet to depressurize the water tank. Drain out 5 gallons of water from the drain valve at the bottom of the heater. Remove the anode rod. See the "Repair Parts Illustration" for anode rod location on page 15.

Water Heater Sounds

During the normal operation of the water heater, sounds or noises may be heard. These noises are common and may result from the following:

1. Normal expansion and contraction of metal parts during periods of heat-up and cool-down.
2. Sediment buildup in the tank bottom will create varying amounts of noise and may cause premature tank failure. Drain and flush the tank as directed under "Draining and Flushing".

Stacking

Stacking occurs when a series of short draws of hot water (3 gallons or less) are taken from the water heater tank. This causes increased cycling of the heater elements and can result in increased water temperatures at the hot water outlet. An anti-scald device is recommended in the hot water supply line to reduce the risk of scald injury.

Maintenance

Temperature and Pressure Relief Valve

WARNING



Explosion Hazard

If the temperature and pressure relief valve is dripping or leaking, have a licensed plumber repair it.

Do not plug valve.

Do not remove valve.

Failure to follow these instructions can result in death, or explosion.

Manually operate the temperature and pressure relief valve at least once a year to make sure it is working properly. To prevent water damage, the valve must be properly connected to a discharge line which terminates at an adequate drain.

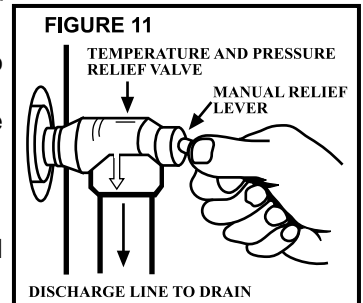

Standing clear of the outlet (discharged water may be hot), slowly lift and release the lever handle on the temperature and pressure relief valve to allow the valve to operate freely and return to its closed position. If the valve fails to completely reset and continues to release water, immediately shut-off the electrical power and the cold water inlet valve and call a qualified service technician.

Draining and Flushing

The water heater should be drained if being shut down during freezing temperatures. It is recommended that the tank be drained, and flushed every 6 months to remove sediment which may buildup during operation. To drain the tank perform the following steps:

1. Turn off the power to water heater.
2. Close the cold water inlet valve and open a nearby hot water faucet.
3. Connect a hose to the drain valve and terminate it to an adequate drain.

Important: Drain hose should be rated for at least 200°F. If the drain hose does not have this rating, open the cold water inlet valve and a nearby hot faucet until water is no longer hot.

4. Open the water heater drain valve and the nearest hot water faucet. Allow all the water to drain from the tank. Flush the tank with water as needed to remove sediment.
5. Close the drain valve, refill the tank, and restore power.

If the water heater is going to be shut down for an extended period, the drain valve should be left open.

NOTE: When draining Table Top models, remove the screw securing the drain access cover. Remove the cover by pulling down and away from the water heater.

Heating Element Replacement

! WARNING	
	<p>Electrical Shock Hazard Disconnect power before servicing. Replace all parts and panels before operating. Failure to do so can result in death or electrical shock.</p>

Replacement heating elements must be of the same style and voltage/wattage rating as the ones presently in the water heater. This information can be found on the flange or terminal block of the element or on the water heater data plate.

1. Shut-off the electric power to the water heater.
2. Drain the water heater as directed under "Draining and Flushing".
3. Remove the access cover(s). Fold the insulation outward and away from the heater element(s). Remove the plastic thermostat cover from the thermostat(s) making sure to disengage the attachment point from the thermostat.
4. Disconnect the electric wires from the heating element (Figure 13). Remove the screw-in elements by turning the element counterclockwise with a 1-1/2 inch socket wrench. Remove the existing gasket.

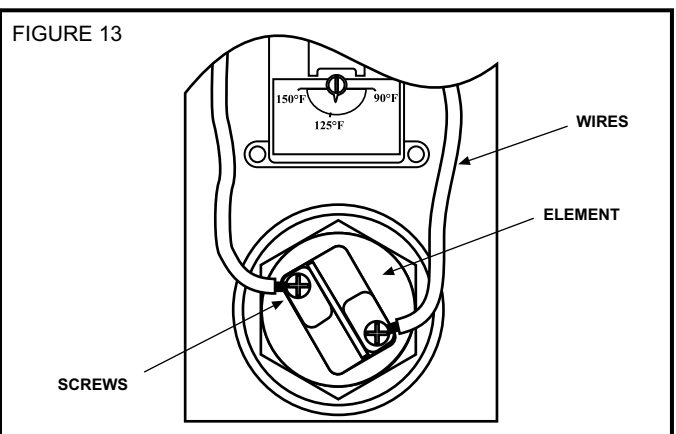

5. Clean the area where the gasket fits to the tank. If you are replacing the bottom element, remove the accumulated sediment on the bottom of the tank.
6. Make sure the replacement element has the correct voltage and wattage rating. Position the new gasket on the element and insert it into the water heater tank (Figure 14). Tighten the element by turning it clockwise until secure.

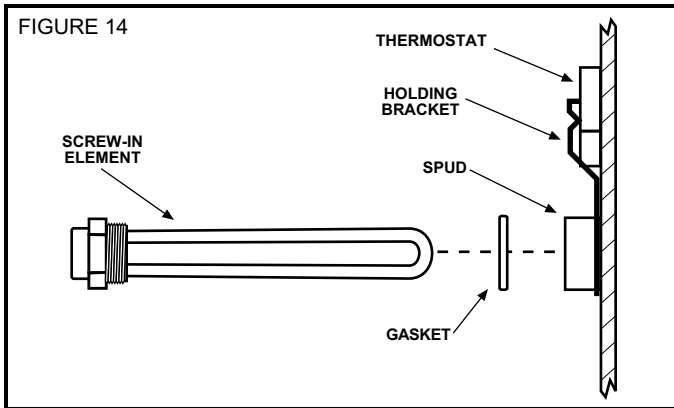

7. Close the drain valve. Open the nearest hot water faucet and allow the tank to fill completely with water. To purge the lines of any excess air and sediment, keep the hot water faucet open for 3 minutes after a constant flow of water is obtained.
8. Check for leaks around the element(s).

9. Connect the electric wires to the heater element. Make sure the wires are secure. Replace the plastic thermostat cover making sure the attachment points are engaged on the thermostat.
10. Replace the access cover(s).
11. Make certain the tank is filled with water. Applying electric current to heater elements not submerged in water will destroy them.
12. Restore the electric power supply to the water heater.

TROUBLESHOOTING CHART

PROBLEM	POSSIBLE CAUSE(S)	CORRECTIVE ACTION
NO HOT WATER	<ol style="list-style-type: none"> 1. No power to heater 2. High Temperature Limit Switch open 3. Defective upper thermostat 	<ol style="list-style-type: none"> 1. Turn on electrical switch. Check for blown fuses or tripped breaker 2. Reset. Check for source of trouble and correct 3. Replace thermostat
INSUFFICIENT HOT WATER	<ol style="list-style-type: none"> 1. Defective thermostats 2. Defective lower element 3. Improper calibration 4. Thermostats set too low 5. Sediment or lime in tank 6. Heater too small for job 7. Wrong piping connections 8. Leaking faucets 9. Wasted hot water 10. Long runs of exposed pipe 11. Hot water piping on outside wall 	<ol style="list-style-type: none"> 1. Replace thermostats 2. Replace element 3. Replace thermostats 4. Set thermostats to desired temperature 5. Drain. Determine if water treatment is needed 6. Install adequate water heater 7. Correct piping 8. Repair faucets 9. Advise customer 10. Insulate piping 11. Insulate piping
HIGH OPERATION COSTS	<ol style="list-style-type: none"> 1. Improper Calibration 2. Thermostats set too high 3. Sediment or lime in tank 4. Heater too small for job 5. Wrong piping connections 6. Leaking faucets 7. Wasted hot water 8. Long runs of exposed piping 9. Hot water piping in exposed wall 	<ol style="list-style-type: none"> 1. Replace thermostats 2. Set thermostat to desired setting 3. Drain. Flush-Provide water treatment if needed 4. Install adequate heater 5. Correct piping 6. Repair faucets 7. Advise customer 8. Insulate piping 9. Insulate piping
SLOW HOT WATER RECOVERY	<ol style="list-style-type: none"> 1. Defective upper element 2. Defective lower element 	<ol style="list-style-type: none"> 1. Replace element 2. Replace element
DRIP FROM RELIEF VALVE	<ol style="list-style-type: none"> 1. Excessive water pressure 2. Closed system 	<ol style="list-style-type: none"> 1. Use Pressure Reducing Valve and Pressure Relief Valve 2. See page 7, "Closed System"
THERMOSTAT FAILS TO SHUT OFF	<ol style="list-style-type: none"> 1. Defective thermostats 2. Improper calibration 	<ol style="list-style-type: none"> 1. Replace thermostats 2. Replace thermostats
WATER ODOR	<ol style="list-style-type: none"> 1. Sulfides in the water 	<ol style="list-style-type: none"> 1. See page 11, "Water Odor"

REPAIR PARTS ILLUSTRATION

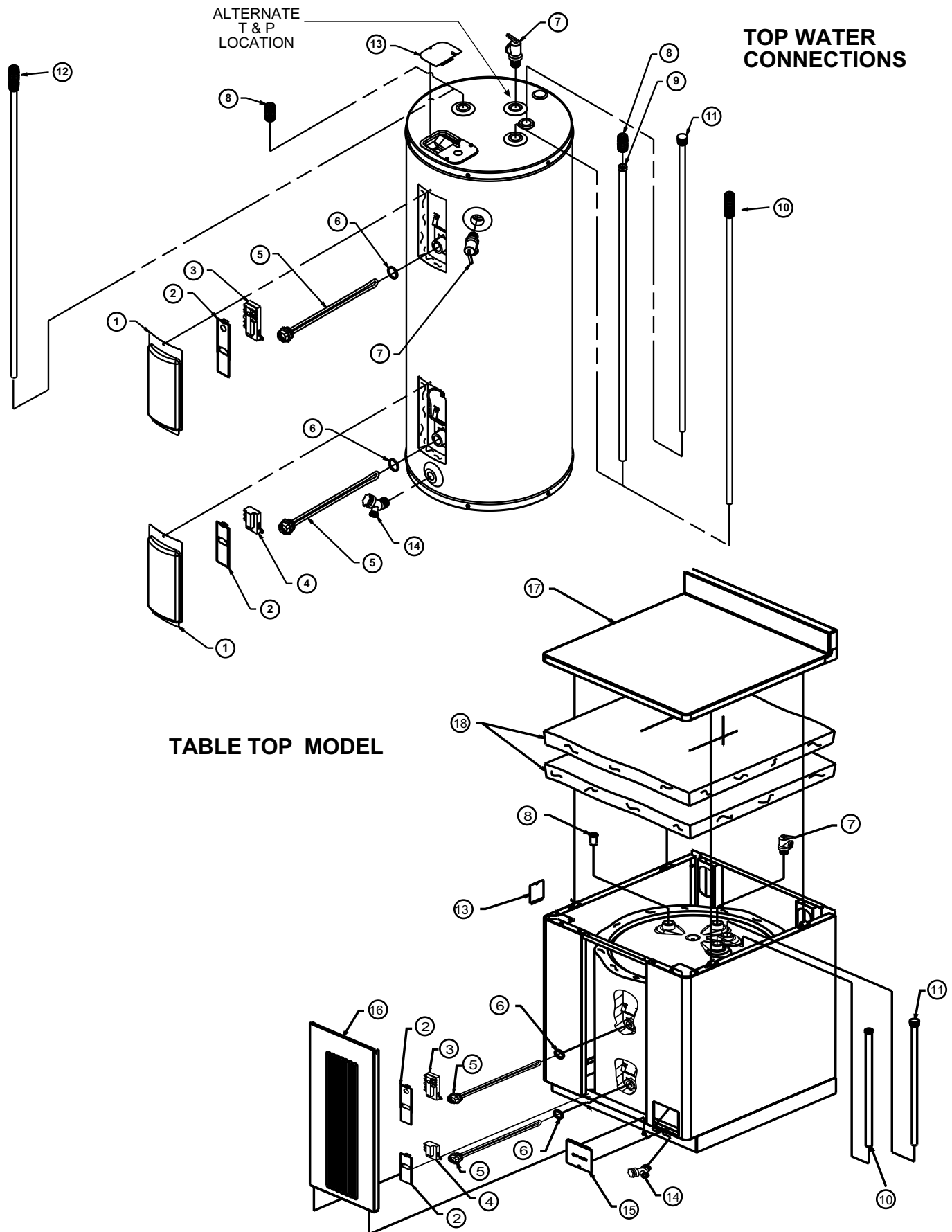

REPAIR PARTS ILLUSTRATION

SIDE WATER CONNECTIONS

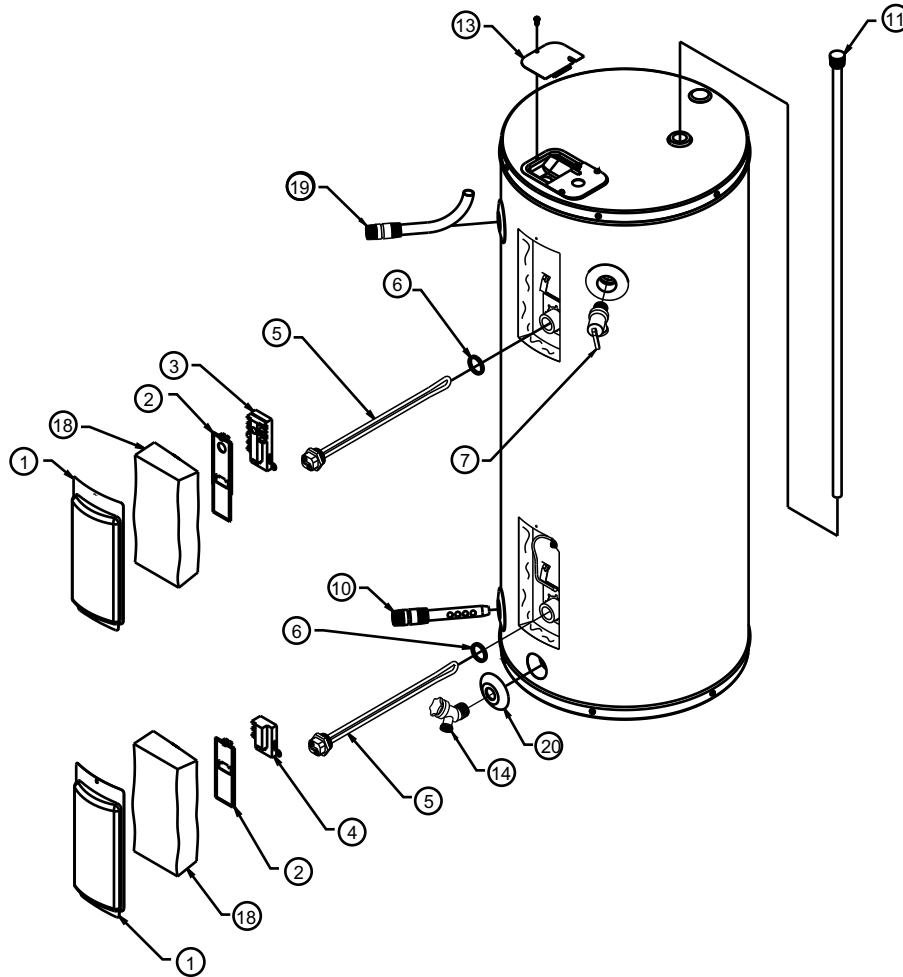

REPAIR PARTS

Repair parts may be ordered through your plumber, local distributor, home improvement center, or by calling 1-800-999-9515. When ordering repair parts always give the following information:

1. Model, serial and product number
2. Item number
3. Parts description

REPAIR PARTS LIST

LEGEND

- ◆ Special anode rod (See page 11)
- Temperature and Pressure Relief Valve is required, but may not be factory installed.
- ▲ Specify thermostat type when ordering.
- Exclusive to the Table Top Water Heaters.

ITEM NO.	PARTS DESCRIPTION
1	ACCESS DOORS
2	THERMOSTAT COVERS (UPPER & LOWER)
3	UPPER THERMOSTAT ▲
4	LOWER THERMOSTAT ▲
5	ELEMENT
6	ELEMENT GASKET
7	TEMPERATURE AND PRESSURE RELIEF VALVES ■
8	HEAT TRAPS
9	DIP TUBE
10	HEAT TRAP/DIP TUBE COMBINATION
11	ANODE ROD ◆
12	HEAT TRAP/ANODE ROD COMBINATION ◆
13	JUNCTION BOX COVER
14	DRAIN VALVE
15	PANEL DRAIN ACCESS ●
16	FRONT PANEL ●
17	TOP PANEL ●
18	INSULATION
19	HEAT TRAP/J-TUBE COMBINATION
20	FLANGE

THERMOSTAT WIRING DIAGRAM

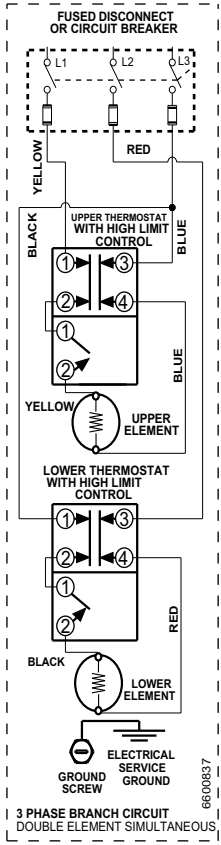
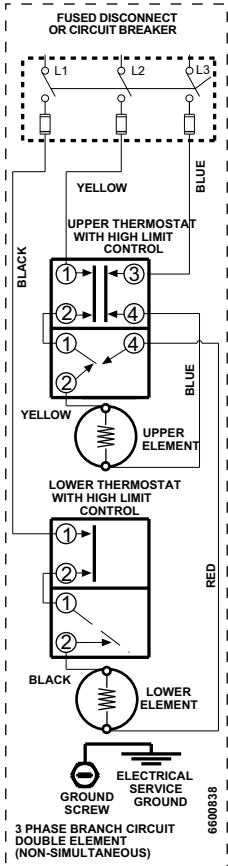
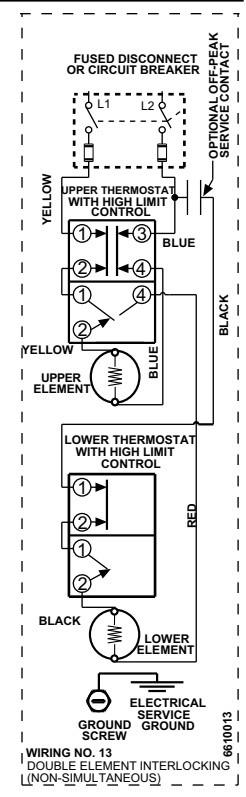
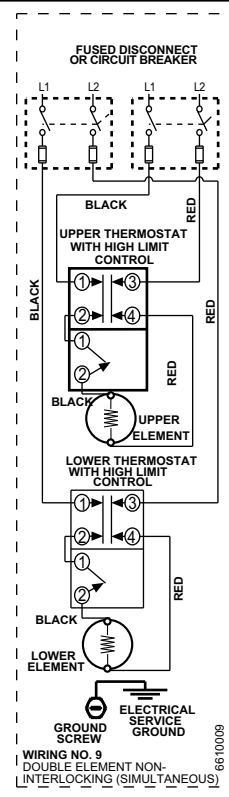
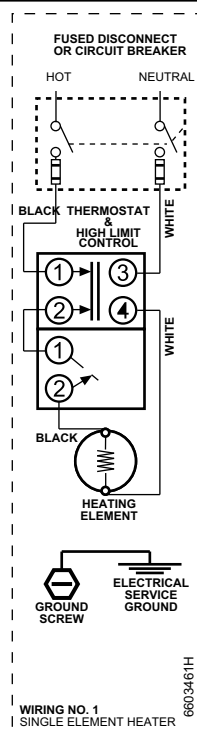
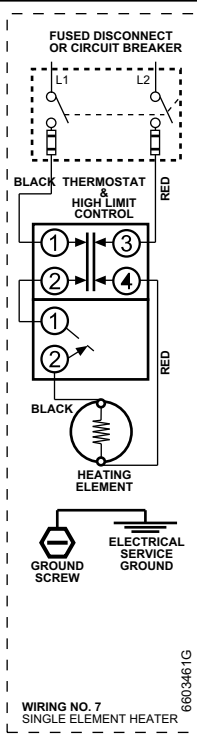
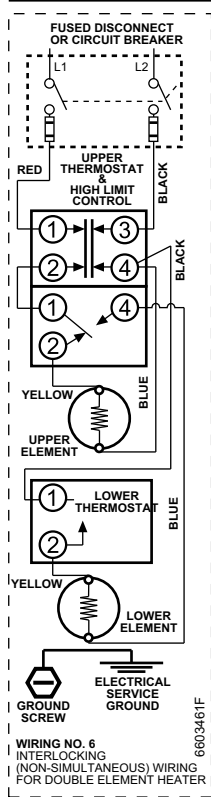

BRANCH CIRCUIT SIZING GUIDE						
Based on N.E.C. NFPA NO. 70 - 1999						
WATT LOAD	Recommend Over Current Protection Rating			Copper Wire Size AWG Based on N.E.C. Table 310 - 16 (60°C)		
	120 V	208 V	240 V	120 V	208 V	240 V
1500*	15	15	15	12	14	14
2000	20	15	15	10	14	14
2500	30	15	15	10	14	14
3000	30	20	15	8	12	12
3500	-	20	20	-	10	12
4000	-	25	20	-	10	10
4500	-	30	25	-	10	10
5000	-	30	30	-	10	10
5500	-	35	30	-	8	10
6000	-	35	30	-	8	8
9000	-	50	45	-	6	6
12000	-	70	60	-	3	4

* Wattages less than 1500 may be wired 14 gage with 15 amp protection