

6-Year Limited Tank/Parts Warranty*

All residential electric water heaters have the Fused Ceramic Shield lining, a tough, thick, durable coating of ceramic that is fused to the tank's interior surface at 1600°F, forming a corrosion-resistant lining for years of dependable protection and use.

- **Heating Element**

Screw-in, direct immersion, 120-volt heating element for maximum efficiency in multiple wattages and voltages. (4500-watt, 240-volt available on 20U)

- **Foam Insulation**

The tank is surrounded by a thick coat of non-CFC polyurethane foam to trap heat inside the tank, saving energy.

- **T&P Valve**

Conveniently located on the side of the tank to facilitate piping to a drain or external to the building.

- **Flexible 3/4" Water Connections**

Top inlet and outlet ready to use; optional side inlet & outlet plugged.

- **Anode Rod**

Top-mounted, heavy-duty anode for added tank protection, extending the life of the tank.

- **Built-In Electric Junction Box**

Top-located, convenient junction box, ready for 1/2" or 3/4" conduit.

- **Thermostat/High Limit Control**

Single-element thermostat with high limit for single-element heaters.

- **Code Approvals**

Listed to UL 174. All models are certified at 300 PSI test pressure and 150 PSI working pressure.

- **Drain Valve**

Child-resistant, corrosion-resistant drain valve.



**For complete warranty information consult the written warranty of American Water Heaters found at www.americanwaterheater.com, or call (800) 999-9515.*

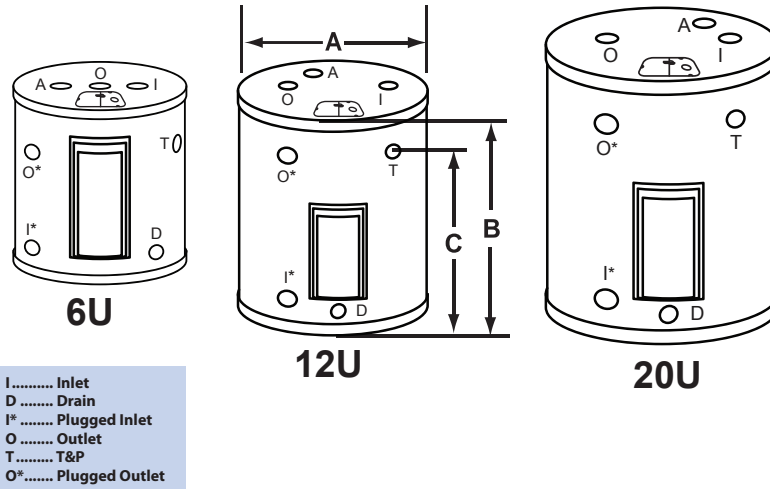

MODEL NUMBER	GALLON CAPACITY	ELEMENTS		GPH RECOVERY 90° RISE	EF	JACKET DIAMETER A	HEIGHT TO TOP OF HEATER	HEIGHT TO SIDE T&P VALVE	APPROX. SHIPPING WEIGHT
		STANDARD	MAXIMUM				B	C	
E61-06U-017SV	6	120V/1650 W	240V/3000 W	7.5	N/A	14-1/4	15-3/8	10-3/4	31
E61-12U-015SV	12	120V/1500 W	240V/4500 W	6.9	N/A	16	22-3/4	16-1/2	49
E61-20U-015SV	19	120V/1500 W	240V/4500 W	6.9	N/A	18	25	18-1/2	65

For 20 gallon lowboy, model E61-19L-045DV, please see spec sheet NRESS00408.

Dimensions and specifications subject to change without notice in accordance with our policy of continuous product improvement. Dimensions on all charts shown in inches.

Specification

Residential electric water heater(s) shall be Utility model _____ as manufactured by American Water Heaters, or an approved equal, and shall have a _____ year tank warranty and a _____ year parts warranty, when installed in a residential application. Heater(s) shall have a storage capacity of _____ gallons and shall have a rated input of _____ KW at _____ Volts, single phase, 60 cycle AC, and shall be designed, tested and listed in accordance with Underwriter's Laboratories standard UL 174. The interior of the storage tank shall be lined with a Fused Ceramic Shield lining, fused to the tank at 1600°F, forming a corrosion-resistant lining; polymer linings are not acceptable. Each tank shall be furnished with an internal anode for cathodic protection. The unit must be equipped with a built-in electrical junction box. Electrical heating element shall be screw-in, direct immersion, resistance type. Element operation shall be controlled by a thermostat for each element. A high temperature cut-off shall be supplied as an integral part of the heater. Element access panel shall be provided on the front of the heater. A corrosion-resistant drain valve shall be provided on the front of each unit. The tank shall be totally encased in a metal jacket and insulated with a non-CFC foam to reduce standby heat loss. The tank must be design certified for 300 PSI test pressure and 150 PSI working pressure.

Distributed By:

Order Entry and Sales

500 Princeton Road (FEDEX, UPS)
 Johnson City, TN 37601-2030
 P.O. Box 4808 (Mailing)
 Johnson City, TN 37602-4808
 (800) 937-1037
 FAX (800) 581-7224

Warranty and Service

500 Princeton Road (FEDEX, UPS)
 Johnson City, TN 37601-2030
 P.O. Box 1597 (Mailing)
 Johnson City, TN 37605-1597
 (800) 999-9515
 FAX (800) 999-5210