

HYBRID ELECTRIC HEAT PUMP AL WITH ANTI-LEAK TECHNOLOGY

The Heat Pump AL smart hybrid electric water heater from American is the most cost-effective, energy-efficient option available for consumers who want to save money on their utility bills. Heat Pump AL combines annual savings up to \$521 per year* on utility bills with new leak protection features to support homeowner peace of mind like leak detection and optional automatic water shutoff.

HOW DO THEY WORK?

Absorb ambient heat from the surrounding air to heat water using a compressor

- Self-contained heat pump unit is integrated into the top of the tank
- Backup electric elements can supplement the heat pump depending on operating mode, environmental conditions and hot water demand

QUALIFIES FOR MANY STATE AND LOCAL UTILITY REBATES - CHECK WWW.AMERICANWATERHEATER.COM

EXCEPTIONAL ENERGY EFFICIENCY

- Improved efficiency up to 4.02 Uniform Energy Factor (UEF) can reduce the cost of water heating by up to 78%*
- Heat pump can work down to 37°F ambient for more days of high efficiency operation
- ENERGY STAR® certified for many state and local utility rebates

iCOMM™ SMART CONNECTIVITY

- Monitor and control your water heater through the free iCOMM app
- Connect through a local Wi-Fi network or directly to the water heater through Bluetooth
- If applicable download the Time of Use schedule of your local electric utility to prioritize heating when the rates are most affordable
- Receive alerts and notifications

LEAK PROTECTION TECHNOLOGY

- Smart anode adapts to local water conditions to protect and extend the life of the water heater
- Controls regulate depletion of the anode to extend the life of the anode allowing superior tank protection far longer than standard anode rods
- User is notified when the anode is consumed and needs to be replaced
- Smart sensor alerts user in the event a leak does occur for added peace of mind

- Compatible with the automatic water shutoff valve for enhanced protection (accessory kit 100356001)

- Notifications through the iCOMM app

QUIET OPERATION

- 45 dBA operating sound level is the quietest heat pump in the industry

FLEXIBLE DESIGN

- Top and front water connections for easy installation
- Zero clearance required on sides and back to fit in tighter spaces
- Integrated ducting adapters for installations in confined spaces
- Ideal for basements, utility rooms or garage installations; the compressor transfers heat to the water while dehumidifying and cooling the ambient air

ELECTRONIC CONTROLS

- User-friendly electronic interface allows easy control of temperature, operating mode and diagnostics

ADVANCED QUALIFICATIONS

- NEEA Tier 4
- California JA13
- CTA-2045 (AC)
- OpenADR 2.0b VEN

10-YEAR LIMITED WARRANTY

- For complete information, consult written warranty or go to americanwaterheater.com



*Comparing 66-gallon Heat Pump AL against pre-2015 similarly-sized standard electric using DOE EF to UEF conversion rates. Savings may vary.



COMMERCIAL-GRADE RESIDENTIAL ELECTRIC WATER HEATERS

Model Number	Nominal Capacity	Rated Storage Volume	UEF	First Hour Rating (Gallons)	Dimensions in Inches							Approx. Shipping Weight (lbs)	Warranty Term
					A	B	C	D	E	F	G		
HPS10250H045DV	50	46	3.80	65	63	22	40.5	3.75	8	43.5	48	196	10
HPS10266H045DV	66	67	4.02	82	61.5	26.5	38.25	4	8	41.25	46	284	10
HPS10280H045DV	80	82	3.88	95	69	26.5	46.5	4	8	50.5	54.5	302	10

Requires 30 amp breaker.
Top T&P option not available on these models.

MULTIPLE OPERATING MODES

Choose from multiple modes to match water heating needs and environmental conditions

- Hybrid (Default): Hot water delivery balanced with energy saving performance
- Heat Pump: Maximum energy efficiency
- Electric: Uses only the electric heating elements
- Vacation: Reduce energy use while you are away

iCOMM SMART CONNECTIVITY

- Download the free iCOMM app to get started.

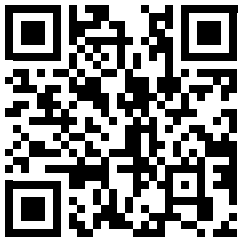

OTHER FEATURES:

- Easily accessible front mounted junction box
- Environmentally-friendly non-CFC foam insulation
- Durable, enhanced-flow brass drain valve
- CSA certified and ASME rated temperature & pressure relief valve

OPERATING REQUIREMENTS:

- Requires provision for non-acidic condensate draining; if a suitable drain is not available a condensate pump is required
- 208/240 VAC 50/60Hz single phase 30 amp power supply

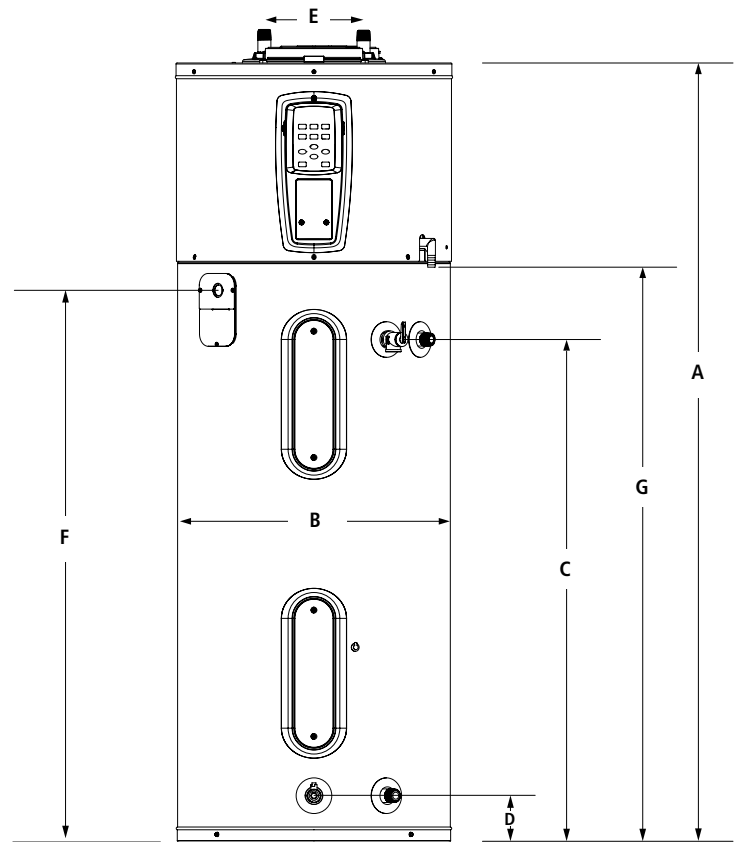

Apple logo and Apple App Store Logo are trademarks of Apple Inc.
Google Play and the Google Play logo are trademarks of Google LLC.

For technical information call (800) 999-9515. American Water Heaters reserves the right to make product changes or improvements without prior notice.

For complete warranty information consult the written warranty of American Water Heaters found at:
www.americanwaterheater.com or call (800) 999-9515 | Copyright © by American Water Heater Company August 2022. All Rights reserved.