

NON-DAMPERED 60

FULLY AUTOMATIC CONTROLS WITH SAFETY SHUTOFF

- Accurate, dependable control system requires no electric connections. Fixed automatic gas shutoff device for added safety. Maximum temperature setting is up to 180°F.

GREEN CHOICE® GAS BURNER

- Patented eco-friendly burner design reduces NOx emissions by up to 33% and complies with Low-NOx emission requirements of less than 40 ng/J.

PUSH-BUTTON PIEZO IGNITOR

- Makes lighting the pilot fast and easy with one-hand push-button spark ignition.

HEAT TRAP NIPPLES

- Factory-installed for faster installation.

BLUE DIAMOND® GLASS COATING

- Provides superior corrosion resistance compared to industry standard glass lining.

ENHANCED-FLOW BRASS DRAIN VALVE

- Designed for easy operation, this valve includes an integral screwdriver slot that features a 1/4 turn (open/close) radius, which not only permits full straight-through water flow but also a quick and positive shut off.

LOWER OPERATING COST

- Eco-Friendly non-CFC foam insulation, external heat traps and specially designed combustion chamber combine for maximum savings on operating costs.

MAXIMUM HYDROSTATIC WORKING PRESSURE 150 PSI

DESIGN-CERTIFIED BY CSA INTERNATIONAL

- Certified at 300 psi test pressure and 150 psi working pressure. Listed according to ANSI Z21.10.1-CSA 4.1 standards governing storage tank-type gas water heaters.

STANDARDS AND CERTIFICATIONS

- Complies with the Federal Energy Conservation Standards effective April 16, 2015, in accordance with the Energy Policy and Conservation Act, (EPCA), as amended.
- CSA certified and ASME rated T&P relief valve.
- Not recommended for sanitation rinse.

3-YEAR LIMITED TANK / 1-YEAR LIMITED PARTS WARRANTY

- For complete information, consult written warranty or go to americanwaterheater.com



CG32-55T60





Commercial Gas Water Heater

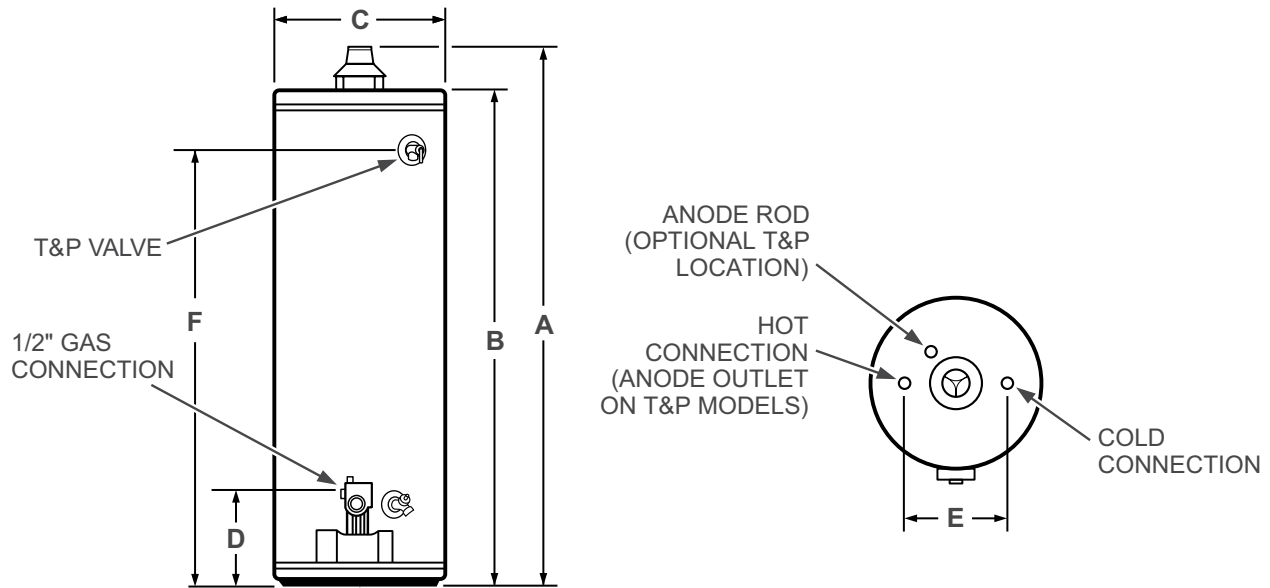

| Model Number | Gallon Capacity | First Hour Rating Gallons | Energy Factor | Recovery Eff. | BTU Input Propane Gas | BTU Input Natural Gas | GPH Recovery @ 100°F Rise Natural | GPH Recovery @ 100°F Rise LP | Dimensions in Inches | | | | | | Approx. Shipping Weight (lbs) | |
|--------------|-----------------|---------------------------|---------------|---------------|-----------------------|-----------------------|-----------------------------------|------------------------------|----------------------|--------|----|--------|---|----|-------------------------------|------------|
| | | | | | | | | | A | B | C | D | E | F | | Draft Hood |
| CG32-55T60 | 55 | 106 | 0.59 | 0.80 | 54,000 | 60,000 | 58 | 52 | 59-3/4 | 55-1/4 | 24 | 13-1/2 | 8 | 48 | 4 | 185 |

| Gas Type | Capacity | | Input Rating | | Temperature Rise GPH (LPH) | | | | | | | | | | | |
|--------------|----------|--------|--------------|---------|----------------------------|-------------|-------------|-------------|-------------|-------------|-------------|--------------|--------------|--------------|--------------|--------------|
| | Gallon | Litres | BTU/HR | kW/ Hr. | 30°F (17°C) | 40°F (22°C) | 50°F (28°C) | 60°F (33°C) | 70°F (39°C) | 80°F (45°C) | 90°F (50°C) | 100°F (56°C) | 110°F (61°C) | 120°F (67°C) | 130°F (72°C) | 140°F (78°C) |
| Natural Gas | 55 | 208 | 60,000 | 17.6 | 194 (734) | 145 (551) | 116 (440) | 97 (367) | 83 (315) | 73 (275) | 65 (245) | 58 (220) | 53 (200) | 48 (184) | 45 (169) | 42 (157) |
| Propane (LP) | 55 | 208 | 54,000 | 15.8 | 175 (661) | 131 (496) | 105 (396) | 87 (330) | 75 (283) | 65 (248) | 58 (220) | 52 (198) | 48 (180) | 44 (165) | 40 (152) | 37 (142) |

Recovery capacities based on actual performance tests.

Water connection is 3/4" on all models

All models approved for installation from sea level to 10,100 ft. elevation.

Dimensions and specifications subject to change without notice in accordance with our policy of continuous product improvement.

Specify natural or propane gas when ordering.

FLAMMABLE VAPOR IGNITION RESISTANT (FVIR) WATER HEATERS

American FVIR design meets the American National Standards Institute standards (ANSI Z21.10.1-CSA 4.1) that deal with the accidental or unintended ignition of flammable vapors, such as those emitted by gasoline.

SPECIFICATION

Water heater(s) shall be Model CG32-55T60 as manufactured by American Water Heaters or an approved equal. Water heater(s) shall be of glasslined design, and gas-fired, equipped to burn _____ gas and design certified by CSA to meet ANSI Z21.10.1 - CSA 4.1. Heaters must meet all applicable energy codes. Heaters shall have an input rating of ____ BTU/H and a recovery capacity of ____ GPH at a temperature rise of 100°F with a storage capacity of 55 gallons. Heater shall have a working pressure of 150 psi and shall be provided with an automatic gas shutoff device and safety shutoff in the event the pilot flame is extinguished; a gas pressure regulator set for the type of gas supplied; an approved draft diverter, and extruded anode rod rigidly supported for cathodic protection. A CSA Certified and ASME Rated T&P Relief Valve shall be furnished and installed by the manufacturer. The tank shall be foam insulated. The outer jacket shall have a baked enamel finish over a bonderized undercoating. All internal surfaces of the heater exposed to water shall be glasslined with an alkaline borosilicate composition that has been fused-to-steel by firing at a temperature range of 1400° to 1600°F. Water Heater tank shall have a three year limited warranty against corrosion and tank failure due to sediment build-up as outlined in the written warranty. Operation of the heater in a closed system where thermal expansion has not been compensated for with a properly sized expansion tank will void the warranty. Fully illustrated instruction manual and parts list to be included.

For technical information call (800) 458-456-9805. American Water Heaters reserves the right to make product changes or improvements without prior notice.