

LIGHT-SERVICE COMMERCIAL ELECTRIC WATER HEATERS

Designed for light duty commercial applications with intermittent hot water loads.

GLASSLINED TANK

- Tank interior is coated with glass specially designed by American for water heater use

HEATING ELEMENTS

- Two 6.1 KW zinc plated copper sheathed elements are standard

STANDARD VOLTAGES

- The standard voltage is 277V single phase

TOP MOUNTED RECESSED JUNCTION BOX

CONTROLS

- Thermostat is adjustable through a range of 120° to 181°F with a manual reset high temperature cutoff. The heater is wired for simultaneous single phase operation.

COREGARD™ ANODE ROD

- Our anode rods have a stainless steel core that extends the life of the anode rod allowing superior tank protection for longer than standard anode rods

ENHANCED-FLOW BRASS DRAIN VALVE

- Solid brass, tamper resistant, enhanced-flow, ball type, drain valve

MAXIMUM WORKING PRESSURE 150 PSI

FACTORY INSTALLED CSA CERTIFIED AND ASME RATED TEMPERATURE AND PRESSURE RELIEF VALVE

CERTIFIED TO UL 1453 FOR COMMERCIAL ELECTRIC WATER HEATERS

COMPLIANCE

- Meets the standby loss requirements of the U.S. Department of Energy and current edition of ASHRAE/IES 90.1

WARRANTY

- 6-Year limited tank/1-Year limited parts
- For complete information consult the written warranty or go to americanwaterheater.com



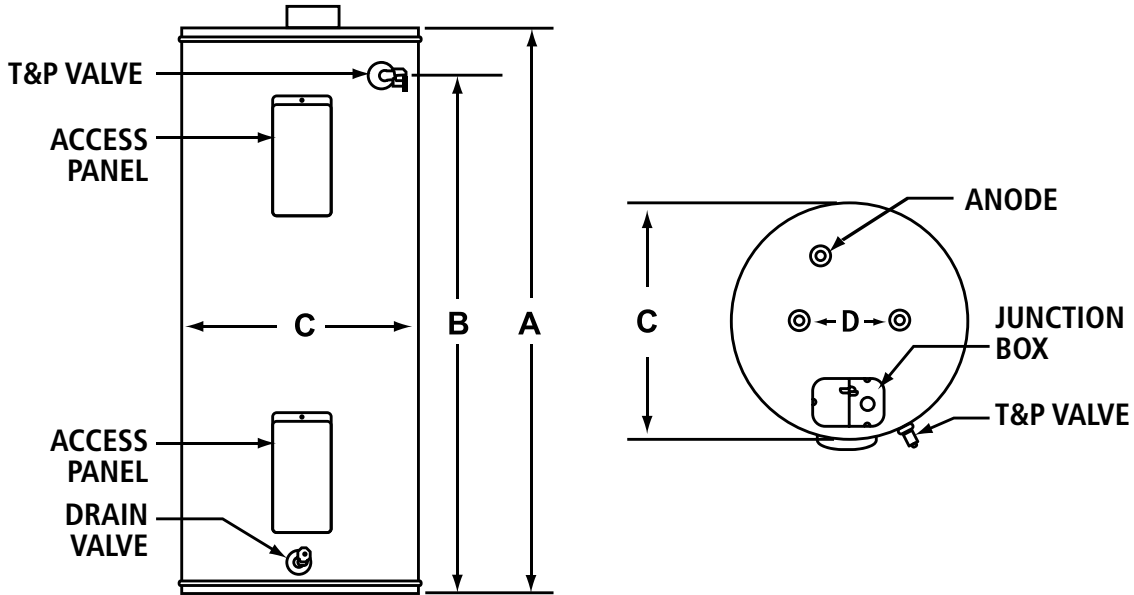

PRODUCT SPECIFICATIONS

Model Number	Gallon Capacity	Standard Element Wattage	Dimensions in Inches				Approx. Shipping Weight (lbs)
			A	B	C Diameter	D	
VSCE62 65H	66	6100	60-1/4	53	22	8	146
VSCE62 80H	80	6100	60-1/2	52-1/4	24	8	175
VSCE62 119R	119	6100	61-1/2	54-1/2	28	8	268

Not available with top mounted T&P valve option.
Inlet and outlet connections: 3/4".

RECOVERY CAPACITIES

Element Wattage (Upper/Lower)	Input kW	U.S. Gallons/Hour and Liters/Hour at Indicated Temperature Rise												
		°F	36	40	54	60	72	80	90	100	108	120	126	°F
		°C	20	22.2	30	33.3	40	44.4	50	55.5	60	66.6	70	°C
Simultaneous														
6100/6100	12.2	GPH	125	113	84	75	63	56	50	45	42	38	36	GPH
		LPH	474	427	316	285	237	213	190	171	158	142	135	LPH

Standard factory wiring is for simultaneous operation.

SPECIFICATION

The water heaters(s) shall be Model(s) No. _____ as manufactured by American or an approved equal. Heater(s) shall be rated at _____kW, _____volts, single-phase, 60 cycle AC, and listed by Underwriters' Laboratories. Models shall meet the standby loss requirements of the U.S. Department of Energy and current edition of ASHRAE/IES 90.1. Tank(s) shall be _____gallon capacity. Heater(s) shall have 150 psi working pressure and be equipped with an extruded high density anode rod. All internal surfaces of the heater(s) exposed to water shall be glasslined with an alkaline borosilicate composition that has been fused-to-steel by firing at a temperature range of 1400°F to 1600°F. Electric heating elements shall be zinc plated copper sheath. Each element shall be controlled by an individually mounted thermostat and high temperature cutoff switch. The outer jacket shall be of baked enamel finish and shall enclose the tank with foam insulation. The drain valve shall be located in the front for ease of servicing. Heater tank shall have a three year limited warranty as outlined in the written warranty. Fully illustrated instruction manual to be included.

For technical information call (800) 456-9805. American Water Heaters reserves the right to make product changes or improvements without prior notice.