

MOBILE HOME



APPROVED FOR MANUFACTURED HOUSING

- All residential electric water heaters are compliant with HUD Standards for mobile homes/ manufactured housing.

SIDE WATER CONNECTIONS

- For ease of installation in mobile home applications.

COREGARD™ ANODE ROD

- Our anode rods have a stainless steel core that extends the life of the anode rod allowing superior tank protection far longer than standard anode rods.

LONG-LASTING HEATING ELEMENTS

- Screw-in, direct immersion, 3500W/240V or 3000W/120V heating elements for maximum efficiency.

BLUE DIAMOND® GLASS COATING

- Provides superior corrosion resistance compared to industry standard glass lining.

ENHANCED-FLOW BRASS DRAIN VALVE

- Our residential water heaters have a solid brass, tamper resistant, enhanced-flow, ball type, drain valve.
- Uses a standard female hose fitting that allows for fast and easy draining during maintenance.
- Designed for easy operation, this valve includes an integral screwdriver slot that features a ¼ turn (open/close) radius, which not only permits full straight-through water flow but also a quick and positive shut off.

CODE COMPLIANCE

- Meets UBC, CEC and HUD National Codes.
- Meets the thermal efficiency and standby loss requirements of the U.S. Department of Energy and current edition of ASHRAE/IESNA 90.1
- Complies with the Federal Energy Conservation Standards effective April 16, 2015, in accordance with the Energy Policy and Conservation Act (EPCA), as amended.

CERTIFIED TO UL 174 FOR HOUSEHOLD ELECTRIC WATER HEATERS

CSA CERTIFIED AND ASME RATED T&P RELIEF VALVE

DESIGN-LISTED BY UNDERWRITERS LABORATORIES

- Certified at 300 PSI test pressure and 150 PSI working pressure.
- Listed according to UL 174 standards governing storage tank-type electric water heaters.

6-YEAR LIMITED TANK AND PARTS WARRANTY

- For complete information, consult written warranty or go to www.americanwaterheater.com.



Low Lead Content





Residential Electric Water Heaters

Model Number	Gallon Capacity	First Hour Rating Gallon	Energy Factor	Recovery @ 90°F Rise Gallon Per Hour	Voltage	Wattage		Dimensions in Inches					Approx. Shipping Weight (lbs)
						Upper Element	Lower Element	A	B	C	D	E	
MHE6-30H-030D	30	42	0.95	14	120	3000	3000	46-3/4	39-1/2	19	3-7/8	39-5/8	98
MHE6-30H-035D	30	42	0.95	16	240	3500	3500	46-3/4	39-1/2	19	3-7/8	39-5/8	98
MHE6-40R-030D	40	51	0.95	14	120	3000	3000	50	40-3/4	22	4-3/8	41	109
MHE6-40R-035D	40	51	0.95	16	240	3500	3500	50	40-3/4	22	4-3/8	41	109
MHE6-30L-030D*	28	40	0.95	14	120	3000	3000	30	21-3/4	22	4-1/2	22	96
MHE6-30L-035D*	28	40	0.95	16	240	3500	3500	30	21-3/4	22	4-1/2	22	96

*Models ship with supplied insulation blanket.

MHE6 models have limited element options due to element size or other restrictions.

Top T&P option not available on these models.

3/4" water connections.

Dimensions and specifications subject to change without notice in accordance with our policy of continuous product improvements.

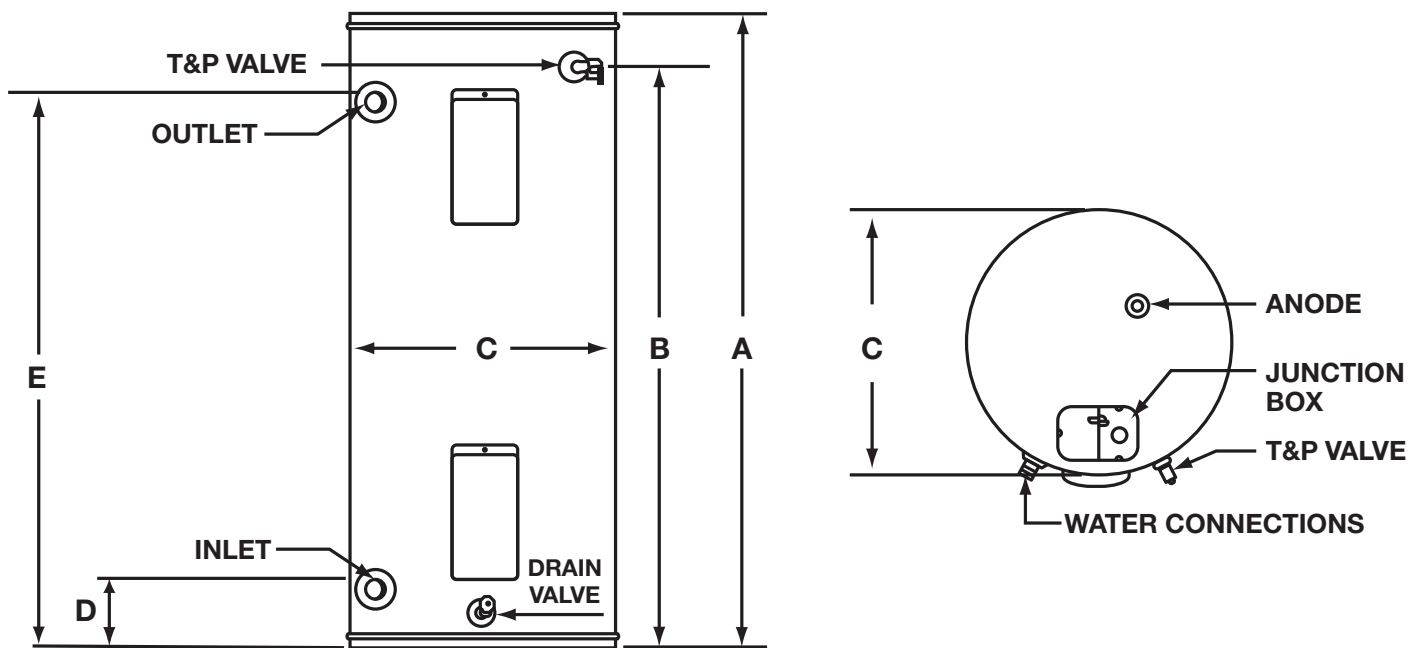

For technical information call (800) 999-9515. American Water Heaters reserves the right to make product changes or improvements without prior notice.