

**COMMERCIAL GAS WATER HEATERS**



PO Box 1597, 500 Princeton Road  
Johnson City, TN 37605

**FOR MODELS: BCL  
381T1206NOX, 381T1546NOX, 395T1806NOX,  
395T1996NOX, 395T2506NOX  
ULTRA LOW NOx SERIES 104**

**INSTALLATION CONSIDERATIONS - PRE SERVICE CHECKS -  
CONSTRUCTION - OPERATION & SERVICE - TROUBLESHOOTING**



**SERVICING SHOULD ONLY BE PERFORMED BY A QUALIFIED SERVICE TECHNICIAN**



# TABLE OF CONTENTS

---

INTRODUCTION .....	2
QUALIFICATIONS .....	2
TOOLS REQUIRED .....	3
INSTALLATION CONSIDERATIONS .....	4
GAS AND ELECTRICAL CHARACTERISTICS .....	4
GAS PRESSURE – REQUIREMENTS .....	4
FEATURES AND COMPONENTS .....	8
BLOWER AND BURNER ASSEMBLY .....	9
SPARK IGNITER, FLAME SENSOR, SIGHT GLASS .....	11
VENTING .....	12
VENTING TABLES – TECHNICAL VENTING DATA .....	14
OPERATION AND SERVICE .....	15
SEQUENCE OF OPERATION – FLOW CHART .....	16
LIGHTING AND OPERATING LABEL .....	17
TROUBLESHOOTING .....	18
CONTROLS OVERVIEW - CONTROL BOX ASSEMBLY .....	19
PRESSURE SWITCHES – ALL MODELS .....	19
HIGH LIMIT SWITCH/ DIGITAL THERMOSTAT .....	20
CONTINUITY CHECK OF HIGH LIMIT (ECO) .....	22
UPPER TEMPERATURE PROBE CONTINUITY CHECK .....	23
LOWER TEMPERATURE PROBE CONTINUITY CHECK .....	24
IGNITION CONTROL .....	25
START UP/ FLAME RECOVERY/ SAFETY LOCKOUT .....	26
UGB – BLOWER SPEED CONTROL .....	28
WIRING DIAGRAM .....	29

## INTRODUCTION

---

The service handbook is designed to aid in servicing and troubleshooting American Water Heaters BCL commercial water heaters in the field. No duplication or reproduction of this book may be made without the express written authorization of American Water Heaters.

The following text and illustrations will provide you with a step by step procedure to verify proper installation, operation, and troubleshooting procedures. Additional quick reference data is included to assist you in servicing these products.

The information contained in this handbook is designed to answer commonly faced situations encountered in the operation of this product line and is not meant to be all inclusive. If you are experiencing a problem not covered in this handbook, please contact American Water Heaters Technical Information at 1-800-456-9805, by email at [help@americanwaterheater.com](mailto:help@americanwaterheater.com), or your local American Water Heaters representative for further assistance. Our website at: [www.americanwaterheater.com](http://www.americanwaterheater.com) is also a resource for installation and service information. This handbook is intended for use by licensed plumbing professionals and reference should be made to the installation manual accompanying the product. This handbook contains supplemental information to the product's installation and operation manual.

## QUALIFICATIONS

---

"Qualified Service Technician" or "Qualified Agency"

Installation and service of this water heater requires ability equivalent to that of a Qualified Agency (as defined by ANSI below) in the field involved. Installation skills such as plumbing, air supply, venting, gas supply and electrical supply are required in addition to electrical testing skills when performing service.

ANSI Z223.1 Sec. 3.3.85: "Qualified Agency" - "Any individual, firm, corporation or company that either in person or through a representative is engaged in and is responsible for (1) the installation, testing or replacement of gas piping or (2) the connection, installation, testing, repair or servicing of appliances and equipment; that is experienced in such work; that is familiar with all precautions required; and that has complied with all the requirements of the authority having jurisdiction."

Service of this water heater requires ability equivalent to that of a Qualified Service Technician in the field involved. Installation skills such as plumbing, air supply, venting, gas supply, electrical supply are required in addition to electrical testing skills. Some products may require combustion testing equipment and certification. If you do not possess these skills or do not have the proper tools you should not attempt to service this water heater.

## SERVICE WARNING

If you are not qualified (as defined by ANSI above) and licensed or certified as required by the authority having jurisdiction to perform a given task do not attempt to perform any of the procedures described in this manual. If you do not understand the instructions given in this manual do not attempt to perform any procedures outlined in this manual.

## SERVICE REMINDER

When performing any troubleshooting step outlined in this manual always consider the wiring and connectors between components. Perform a close visual inspection of all wiring and connectors to and from a given component before replacement. Ensure wires were stripped before being crimped in a wire connector, ensure wires are crimped tightly in their connectors, ensure connection pins in sockets and plugs are not damaged or worn, ensure plugs and sockets are mating properly and providing good contact.

Failure to perform this critical step or failing to perform this step thoroughly often results in needless down time, unnecessary parts replacement, and customer dissatisfaction.

## TOOLS REQUIRED

---

- Electrical multimeter capable of measuring continuity/ ohms, ac & dc volts, amperes, microamperes, millivolts, and frequency (hz)
  - UeI Model DL289 or equivalent
- Digital manometer + 60" w. c., resolution 0.01" increments

**Note:** A digital manometer is required for testing pressure switches and can replace a gas pressure gauge, draft gauge or slack tube manometer for checking gas pressure.

- UeI model EM200 or equivalent
- Water pressure gauge w/lazy hand and hose bibb connection
- Thermometer
- 1-1/16 Inch socket with extension for anode replacement
- Phillips head screwdriver
- Set of numbered drill bits
- Standard screwdrivers
- 3/8, 7/16, 1/2 and 9/16 inch open end wrenches

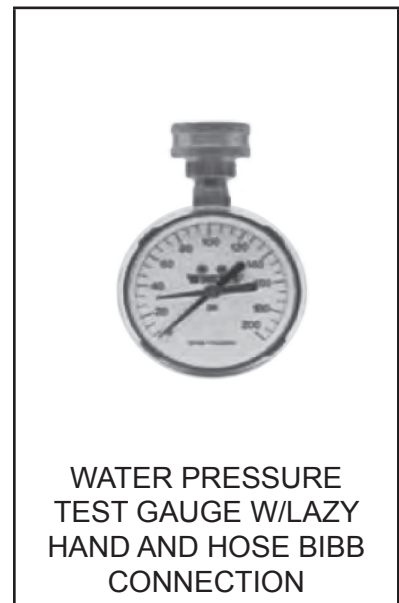

## INSTALLATION CONSIDERATIONS

### GAS AND ELECTRICAL CHARACTERISTICS

MODELS	GAS TYPE	GAS SUPPLY PRESSURE		VOLTS/HZ	AMPERES
		MINIMUM	MAXIMUM		
All Models	Natural	3.5" WC (0.87 kPa)	14.0" WC (3.48 kPa)	120/60	< 5

All models require a minimum gas supply pressure of 3.5" W.C. The minimum supply pressure is measured while gas is flowing (dynamic pressure). The supply pressure (dynamic) should never fall below 3.5" W.C. The supply pressure should be measured with all gas fired appliances connected to the common main firing at full capacity. If the supply pressure drops more than 1.5" W.C. as gas begins to flow to the water heater then the supply gas system including the gas line and/or the gas regulator may be restricted or undersized.

The gas valve on all models has a maximum gas supply pressure limit of 14" W.C. The maximum supply pressure is measured while gas is not flowing (static pressure).

### GAS PRESSURE – REQUIREMENTS

Main line gas pressure to the water heater for natural gas should be between a **maximum** of 14" w.c. (3.48 kPa) static pressure and a **minimum** of 3.5" w.c. (0.87 kPa) dynamic pressure for Natural Gas.

**A supply gas pressure regulator ( service regulator ) must be installed on the gas supply line if the static pressure exceeds 14" w.c. and it should be installed no closer than 3 feet (1 meter), but no farther than 8 feet (2.4 meters) of equivalent length from the water heater's inlet gas connection.**

1. Check gas line pressure with a manometer.
2. Cycle the burner on and off several times to check its operation.
3. Check the operation of the limit and operating controls.
4. Check the vent system seams and joints and ensure that there is no discharge of flue products into the room.
5. Check the input rate.

Supply gas pressure shall be measured while the water heater is not firing (static pressure) and while the water heater is firing at full capacity (dynamic pressure). If the supply gas pressure to the water heater is not between the required minimum and maximum values given in table above, adjust the supply gas regulator as necessary. Adjust the supply gas regulator(s) per the regulator manufacturer's instructions to achieve the required "static" and "dynamic" supply gas pressure.

#### MULTIPLE APPLIANCE INSTALLATIONS:

In multiple water heater installations or in installations where the installed water heater(s) share a common gas supply main with other gas fired appliances; the supply gas pressures shall be measured at each water heater with all gas fired appliances connected to a common main firing at full capacity.

In multiple water heater installations the supply gas line regulators shall be adjusted to provide gas pressure to each water heater within the minimum and maximum supply pressure requirements listed in table above with all gas fired appliances connected to a common gas main firing at full capacity.

**Note:** A pressure drop of more than 1.5" W. C. (0.37 kPa) when the main burner ignites is an indication of an inadequate supply of gas and can lead to ignition failure, rough starts and/or rough operation. If a drop of more than 1.5" W. C. (0.37 kPa) in supply gas pressure occurs when the main burner ignites, ensure the supply gas lines and regulator(s) are properly sized and installed.

## AIR SUPPLY:

Stoichiometric or theoretical complete combustion requires 10 cubic feet of air per 1,000 BTU of gas supplied. The National Fuel Gas Code also recommends an additional 2.5 cubic feet of “excess” air. For information on minimum make-up air opening sizes for various building installations, refer to the National Fuel Gas Code NFPA 54/ANSI Z223.1.

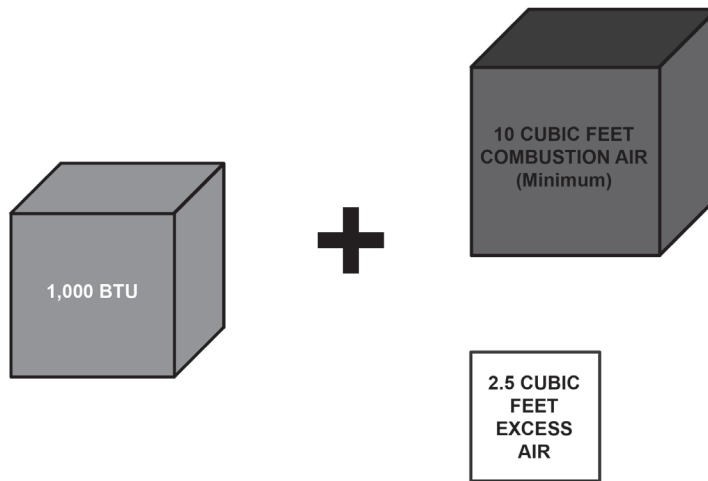

## INSUFFICIENT MAKE-UP AIR, NEGATIVE AIR PRESSURE AND DOWNDRAFTS:

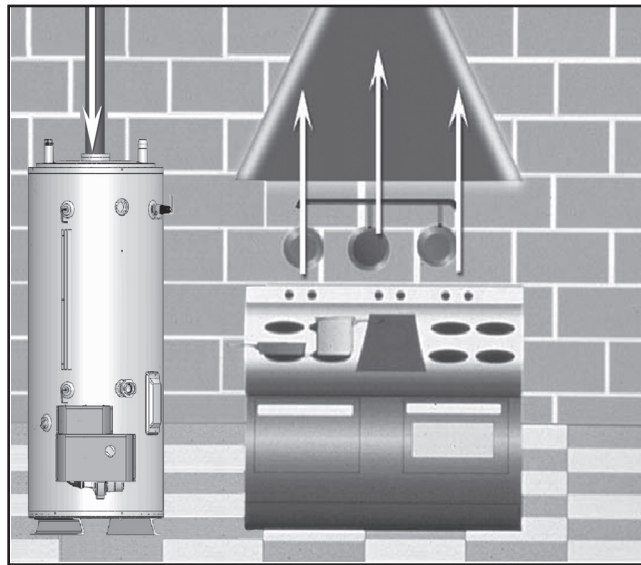

Downdraft Caused by Kitchen Vent Hood

A lack of combustion and ventilation air can create a negative ambient air pressure in the installed space. The vent system on one or more gas fired appliances can experience down drafts due to the outdoor air pressure being greater than the ambient air pressure in the installed space. Where multiple gas fired appliances are installed, one or more gas fired appliances can “pull air” through the vent system(s) of other appliances installed nearby.

One common example is in a restaurant installation where exhaust vent equipment was not considered in sizing make-up requirements. This condition may result in air being back drafted by the restaurant exhaust equipment through the heater causing the draft proving switch to open and/or erratic heater shutdown.

- Down drafts can cause flue gases to spill into the installed space.



## MAKE-UP AIR – DIRECT COMMUNICATION WITH OUTDOORS:

A fresh supply of make-up air for combustion can be supplied to the water heater through make-up air ducts, which directly communicate with the outdoors. (Not Direct Vent.)

Two openings are required: one within 12 inches (30 cm) of the top of the enclosure and one within 12 inches (30 cm) of the bottom of the enclosure. Each opening must have a free area of not less than 1 square inch per 4,000 BTU/Hr of the total input of all appliances within the enclosure. The lower opening primarily provides combustion air. The upper opening provides vent dilution air and acts as a relief opening for flue gases should the vent become obstructed or a downdraft condition occur.

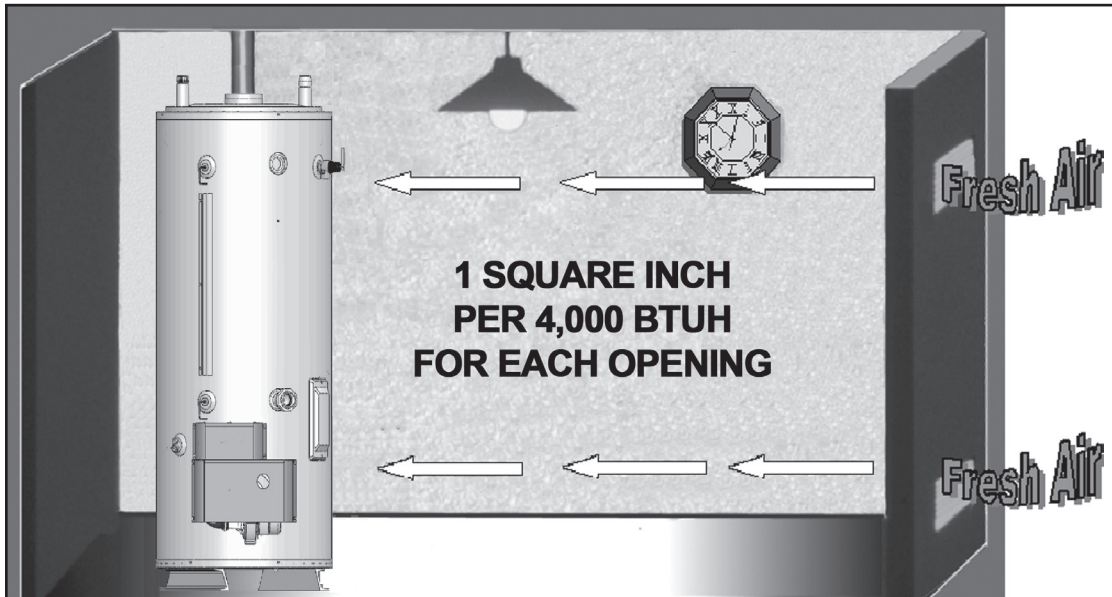

Additionally, when the water heater is installed in a confined space and communicating with the outdoor air, one permanent opening, beginning within 12 inches (30 cm) of the top of the enclosure, must be permitted where the equipment has clearances of at least 1 inch (2.5 cm) from the sides and back, and 6 inches (16 cm) from the front of the appliance. The opening must directly communicate with the outdoors and must communicate through a vertical or horizontal duct to the outdoors or spaces (crawl or attic) that freely communicate with the outdoors, and must have a minimum free area of a) 1 square inch per 3,000 BTU/Hr (7cm<sup>2</sup> per kW) of the total input of all equipment located in the enclosure and b) not less than the sum of the areas of all vent connectors in the confined space.

## CONTAMINATED AIR:

Corrosion of the flue ways and vent system may occur if air for combustion contains certain chemical vapors. Such corrosion may result in failure and risk of asphyxiation.

Combustion air that is contaminated can greatly diminish the life span of the water heater and water heater components such as hot surface igniters and burners. Propellants of aerosol sprays, beauty shop supplies, water softener chemicals and chemicals used in dry cleaning processes that are present in the combustion, ventilation or ambient air can cause such damage.

Do not store products of this sort near the water heater. Air which is brought in contact with the water heater should not contain any of these chemicals. If necessary, uncontaminated air should be obtained from remote or outdoor sources. The limited warranty is voided when failure of water heater is due to a corrosive atmosphere. (See limited warranty for complete terms and conditions).



## **AIR REQUIREMENTS:**

For safe operation an adequate supply of fresh uncontaminated air for combustion and ventilation must be provided. An insufficient supply of air can cause recirculation of combustion products resulting in contamination that may be hazardous to life. Such a condition often will result in a yellow, luminous burner flame, causing sooting of the combustion chamber, burners and flue tubes and creates a risk of asphyxiation.

Do not install the water heater in a confined space unless an adequate supply of air for combustion and ventilation is brought in to that space using the methods described in the Confined Space section of the Instruction Manual.

Never obstruct the flow of ventilation air. If you have any doubts or questions at all, call your gas supplier. Failure to provide the proper amount of combustion air can result in a fire or explosion and cause property damage, serious bodily injury or death.

## **CLOSED WATER SYSTEMS:**

Water supply systems may, because of code requirements or such conditions as high line pressure, among others, have installed devices such as pressure reducing valves, check valves, and back flow preventers. Devices such as these cause the water system to be a closed system.

## **THERMAL EXPANSION:**

As water is heated, it expands (thermal expansion). In a closed system the volume of water will grow when it is heated. As the volume of water grows there will be a corresponding increase in water pressure due to thermal expansion. Thermal expansion can cause premature tank failure (leakage). This type of failure is not covered under the limited warranty. Thermal expansion can also cause intermittent Temperature-Pressure Relief Valve operation: water discharged from the valve due to excessive pressure build up. This condition is not covered under the limited warranty. The Temperature-Pressure Relief Valve is not intended for the constant relief of thermal expansion.

## **CONTAMINATED AIR:**

Corrosion of the flue ways and vent system may occur if air for combustion contains certain chemical vapors. Such corrosion may result in failure and risk of asphyxiation.

Combustion air that is contaminated can greatly diminish the life span of the water heater and water heater components such as hot surface igniters and burners. Propellants of aerosol sprays, beauty shop supplies, water softener chemicals and chemicals used in dry cleaning processes that are present in the combustion, ventilation or ambient air can cause such damage.

Do not store products of this sort near the water heater. Air which is brought in contact with the water heater should not contain any of these chemicals. If necessary, uncontaminated air should be obtained from remote or outdoor sources. The limited warranty is voided when failure of water heater is due to a corrosive atmosphere. (See limited warranty for complete terms and conditions).

## **POWER SUPPLY:**

The water heaters covered in this manual require a 120 VAC, 1Ø (single phase), 60Hz, 15 amp power supply and must also be electrically grounded in accordance with local codes or, in the absence of local codes, with the National Electrical Code, ANSI/ NFPA 70 or the Canadian Electrical Code, CSA C22.1.

# FEATURES AND COMPONENTS

---

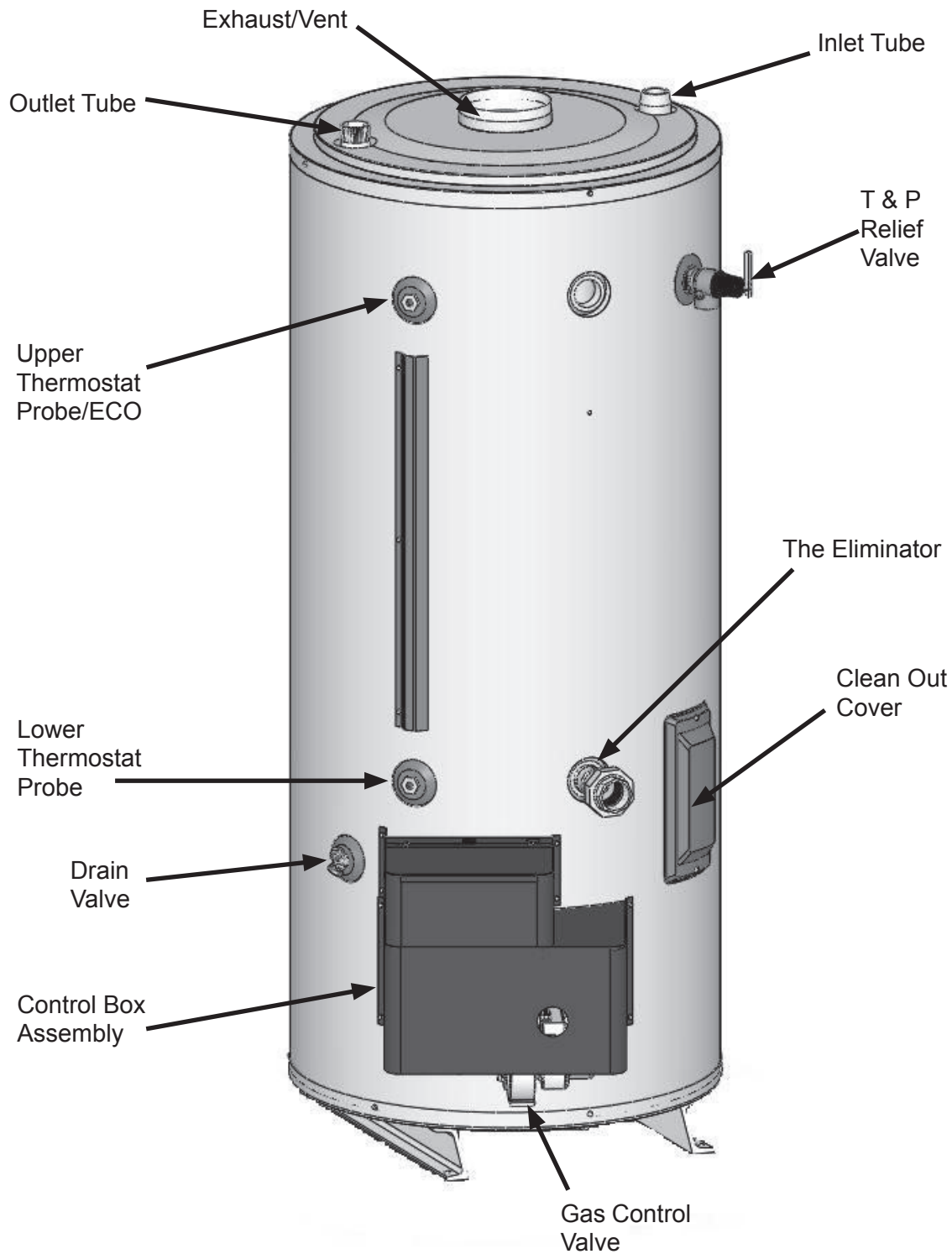

## BLOWER AND BURNER ASSEMBLY

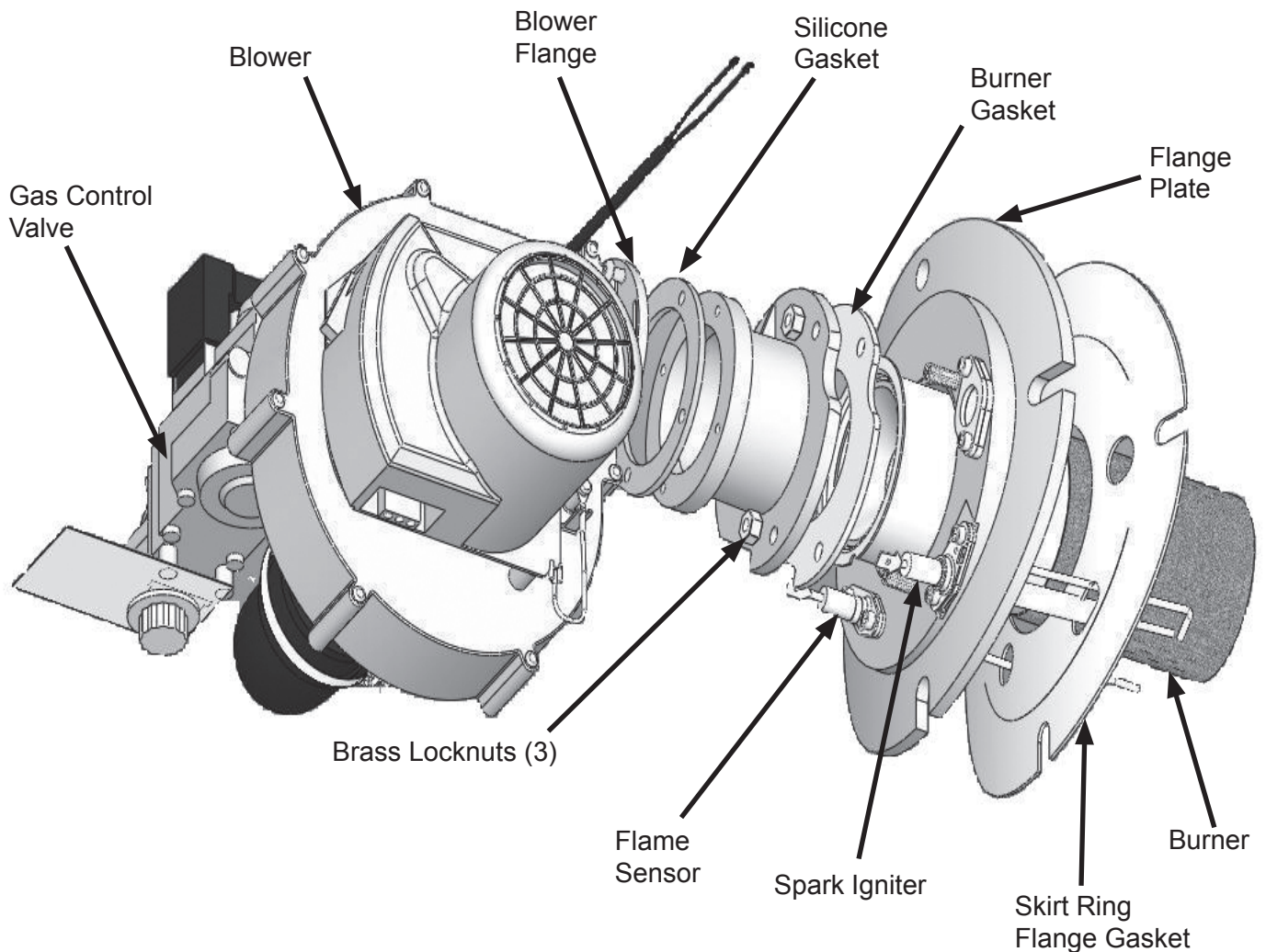

### BURNER REPLACEMENT:

1. Turn off the gas supply and electricity to the water heater and remove the blower cover.
2. Disconnect the spark ignition cable and ground wire plus the flame sensor wire at their connection points on the flange plate.
3. Disconnect the hose tubes, power supply and PWM (Pulse-Width Modulation) control to the blower.
4. Disconnect the gas line near the gas valve.
5. Remove the 4 brass locknuts and 4 flat-washers holding the flange plate to the skirt ring flange.
6. Pull the blower and burner assembly out of the combustion chamber. Take care not to damage the spark igniter or flame sensor during the removal process.
7. Clean the flange plate and skirt ring flange surfaces to remove any portions of the old skirt ring flange gasket.

8. Support the blower and burner assembly in a vertical position with the burner extending downward.
9. Remove the 3 brass locknuts holding the blower adapter to the flange plate.
10. Separate the blower from the flange plate.
11. Clean the flange plate surfaces removing any portions of the old burner gasket.
12. Remove the burner from the flange plate.
13. Insert the new burner into the flange plate and align the notch in the burner flange with the tab in the flange plate.
14. Install the new burner gasket over the three studs extending from the flange plate.
15. Install the blower assembly on the flange plate with the 3 brass locknuts. Torque the nuts to 60 in.lb.
16. Install the new skirt ring flange gasket on the flange plate.
17. Install the blower and burner assembly into the combustion chamber and engage the 4 studs through the mounting holes/slots in the flange plate. Install 4 flat washers and 4 brass locknuts on the studs and torque to 16 ft.lb.
18. Reconnect the gas line.
19. Reconnect the spark ignition cable and ground wire plus the flame sensor wire at their connection points on the flange plate.
20. Reconnect the blower's power supply. PWM control and pressure sensing tubing.
21. Check that all gas connections and fasteners are tight.
22. Turn on the gas supply and electricity to water heater.

## SPARK IGNITER, FLAME SENSOR, SIGHT GLASS

The spark igniter and the flame sense rod are shown below. Also shown is the burner sight glass. These features are typical for all models.

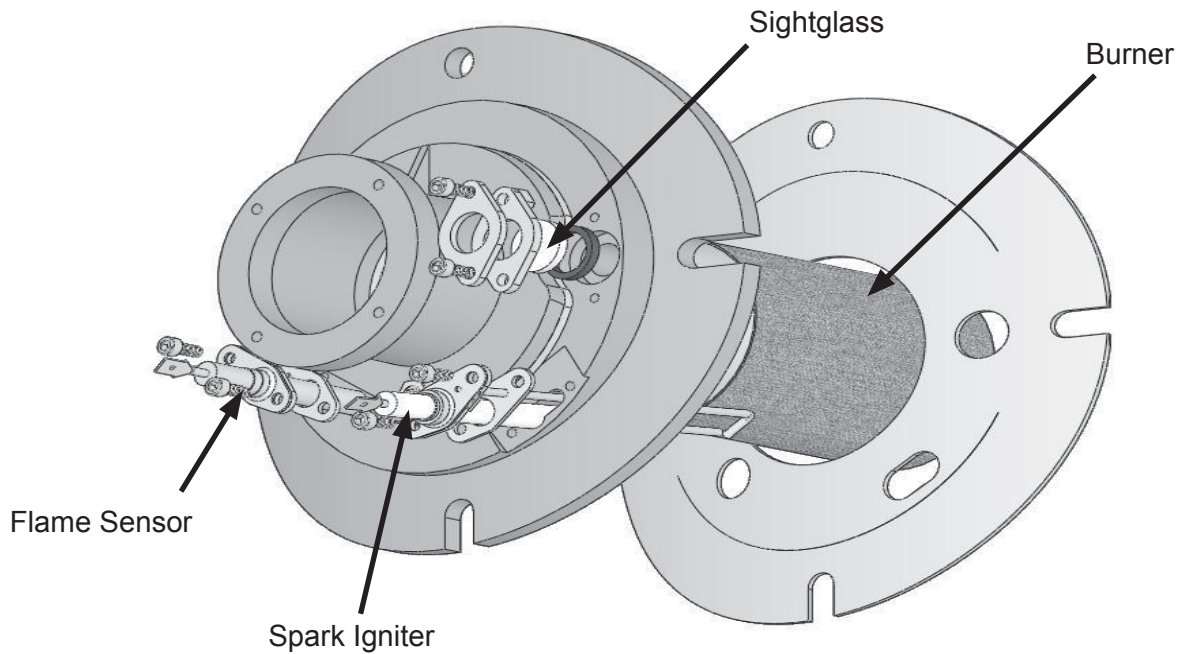

## SPARK IGNITER / FLAME SENSOR / CONTROL TIMING

### SPARK IGNITER

This water heater is equipped with a spark igniter. Do not damage the ceramic insulator. Inspect the igniter ceramic insulator for any cracks. The spark gap between the spark rod and grounding rod is 1/8".

### FLAME SENSOR

This water heater is equipped with a flame sensor. The flame sensor senses flame by passing a small electric current through the flame. This type of flame sensing is also known as flame rectification. The Ignition Control is looking for a minimum current of 0.7 micro amperes for the water heater to operate.

### CONTROL TIMING

Pre-purge	30 seconds
Inter Purge	30 seconds
Trial for ignition	4 seconds
Tries	3
Flame Sensing	Remote
Loss of Flame	Recycle
Reset	15 minutes auto reset
<b>Note:</b> 5 seconds delay between low and high fire rate.	

# VENTING

## INSTALLATION – VENTING CATEGORY AND MATERIALS

BCL VENTING	
Category I	• Non-condensing, negative pressure in vent, below atmospheric.
Type venting	• Must be installed Conventional Vent; uses room air for combustion and discharges flue gases to the outdoor atmosphere through one pipe.
Vent materials	• B Vent.

### MINIMUM CLEARANCES

This water heater is approved for installation on combustible flooring in an alcove with minimum clearance from combustion construction as indicated in below Figure and Table.

In all installations the minimum combustible clearances from vent piping shall be 6" (15.2 cm). Vent piping passing through a combustible wall or ceiling must be a continuous run (no joints) and retain 6" (15.2 cm) clearance unless an approved reducing thimble is used.

A service clearance of 24" (61 cm) should be maintained from serviceable parts, such as Temperature-pressure relief valves, baffles, digital thermostats, cleanout openings or drain valves.

The units are approved for installation with side, rear and ceiling clearances as indicated below:

### MINIMUM CLEARANCES TO COMBUSTIBLE OR NON-COMBUSTIBLE CONSTRUCTION:

MODELS	"A" RIGHT SIDE	"B" LEFT SIDE	"C" BACK	"D" CEILING
BCL-120, 154, 180, 199, 250	0"	0"	0"	12"
	0 cm	0 cm	0 cm	30.5 cm

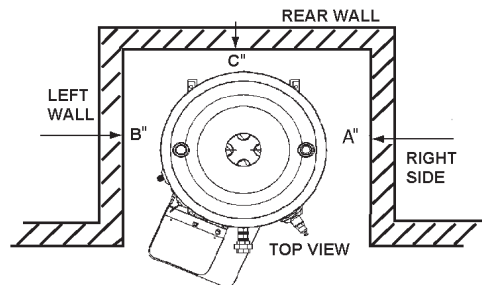
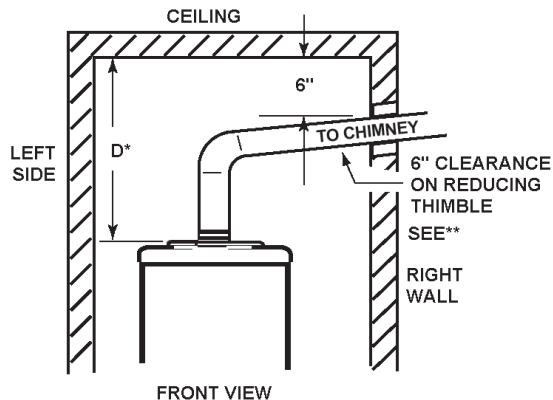

ILLUSTRATION OF MINIMUM COMBUSTIBLE CLEARANCES IN AN ALCOVE

NOTES:  
 \* INCLUDES 6" FROM VENTING AND FLUE BAFFLE SERVICE CLEARANCE.  
 \*\* ALL HORIZONTAL VENT PIPING SHALL HAVE A RISE OF 1/4" PER FOOT MINIMUM.

## EXTERIOR CLEARANCES

The illustration below shows the required clearances for venting units using natural draft venting.

The vent must extend at least 3 feet above the highest point where it passes through a roof of a building and at least 2 feet higher than any portion of a building within a horizontal distance of 10 feet (for vents of 12 inches in diameter or less).

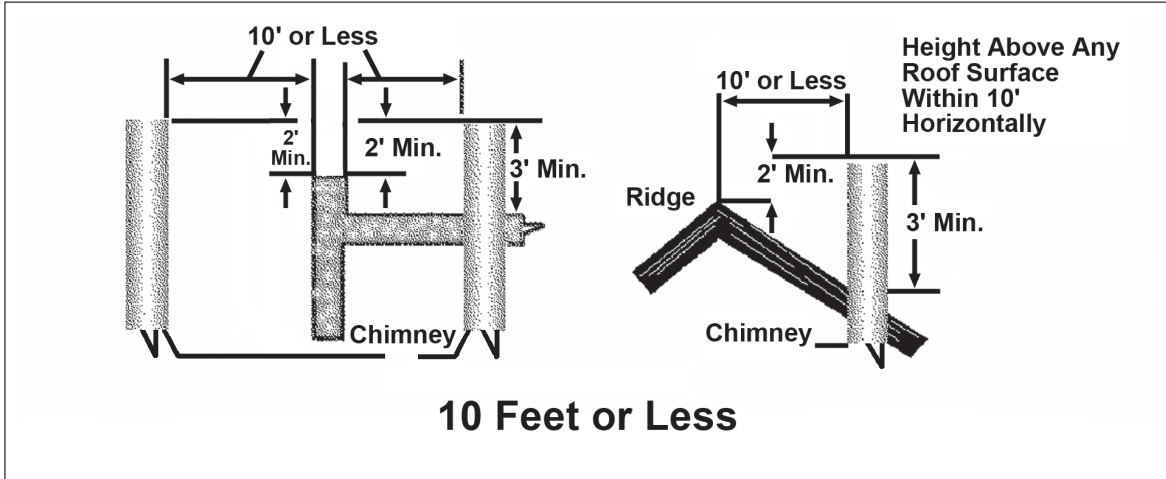



# VENTING TABLES – TECHNICAL VENTING DATA

## TYPE B GAS VENT

### Multiple Gas Fired Tank-Type Heaters

When venting multiple tank type heaters using Type B vent pipe, follow the installation diagram and tables below which give sizing and data based upon NFPA 54 ANSI Z223.1.

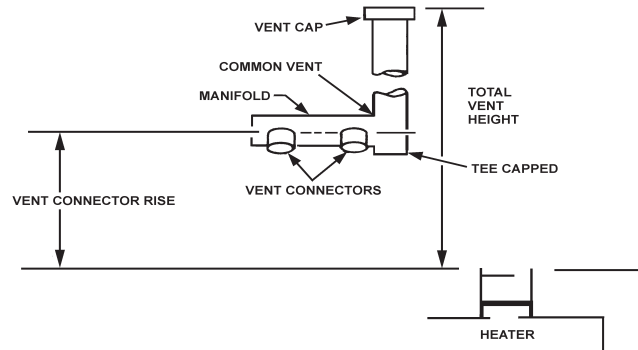

Model BCL381T1206NOX			Total Vent Height (Feet)							
Input: 120,000 Btu/hr			6	8	10	15	20	30	50	100
Vent connector size: 6 inches			Vent Connector Diameter (Inches)							
	Input Btu/hr	Rise								
	120,000	1 ft.	6	6	5	5	5	5	5	5
	120,000	2 ft.	5	5	5	5	5	5	5	5
	120,000	3 ft.	5	5	5	5	5	5	5	5
Number of 120 Heaters	Combined Input in Thousands of Btu/hr	Manifold and Common Vent Diameter (Inches)								
2	240,000	7	7	6	6	6	6	6	6	6
3	360,000	8	8	7	7	7	6	6	6	6
4	480,000	9	9	9	8	8	7	7	6	6
Model BCL381T1546NOX			Total Vent Height (Feet)							
Input: 154,000 Btu/hr			6	8	10	15	20	30	50	100
Vent connector size: 6 inches			Vent Connector Diameter (Inches)							
	Input Btu/hr	Rise								
	154,000	1 ft.	6	6	6	6	6	6	6	6
	154,000	2 ft.	6	6	6	6	6	6	6	6
	154,000	3 ft.	6	6	6	6	6	6	6	6
Number of 154 Heaters	Combined Input in Thousands of Btu/hr	Manifold and Common Vent Diameter (Inches)								
2	308,000	7	7	6	6	6	6	6	6	6
3	462,000	8	8	7	7	7	6	6	6	6
4	616,000	9	9	9	8	8	7	7	6	6
Model BCL395T1806NOX/1996NOX			Total Vent Height (Feet)							
Input: 180,000 and 199,000 Btu/hr			6	8	10	15	20	30	50	100
Vent connector size: 6 inches			Vent Connector Diameter (Inches)							
	Input Btu/hr	Rise								
	180,000	1 ft.	7	7	6	6	6	6	6	6
	199,000	1 ft.	7	7	7	6	6	6	6	6
	180,000	2 ft.	6	6	6	6	6	6	6	6
	199,000	2 ft.	7	7	6	6	6	6	6	6
	180,000	3 ft.	6	6	6	6	6	6	6	6
	199,000	3 ft.	6	6	6	6	6	6	6	6
Number of Heaters	Combined Input in Thousands of Btu/hr	Manifold and Common Vent Diameter (Inches)								
2	360,000	8	8	8	7	7	7	6	6	6
	398,000	8	8	8	7	7	7	6	6	6
3	540,000	10	9	9	9	8	8	7	7	7
	597,000	10	9	9	9	8	8	7	7	7
4	720,000	12	12	10	10	9	9	8	8	8
	796,000	12	12	10	10	9	9	8	8	8
Model (A)BCL395T2506NOX			Total Vent Height (Feet)							
Input: 250,000 Btu/hr			6	8	10	15	20	30	50	100
Vent connector size: 6 inches			Vent Connector Diameter (Inches)							
	Input Btu/hr	Rise								
	250,000	1 ft.	8	8	7	7	6	6	6	6
	250,000	2 ft.	7	7	7	7	6	6	6	6
	250,000	3 ft.	7	7	7	7	6	6	6	6
Number of 250 Heaters	Combined Input in Thousands of Btu/hr	Manifold and Common Vent Diameter (Inches)								
2	500,000	9	9	9	8	8	7	7	7	7
3	750,000	12	12	10	10	10	9	8	8	8
4	1,000,000	14	14	12	12	10	10	9	9	9

## OPERATION AND SERVICE

---

### SEQUENCE OF OPERATION:

1. Switch power on to unit.
2. Thermostat calls for heat.
3. UGB (Universal Gas Board) sends PWM signal to blower to start the blower.
4. Blower runs at high prepurge speed for 20 seconds.
5. Combustion Blower initiates air flow through water heater closing the Prover Switch.
6. After 30 seconds, the Ignition Control provides power to the Spark Igniter and Gas Valve.
7. Ignition Control maintains spark for up to 4 seconds and monitors Flame Sensor to determine if Burner is lit.
8. If the Flame Sensor does not detect proper flame, the Ignition Control shuts off the Gas Valve and allows the Blower to purge the unit. At that time, the Ignition Control restarts with step 6. It will try and ignite the main burners 2 more times. If the unit does not light, the Ignition Control will wait 15 minutes and then restart at step 6. This cycle will continue until the unit lights or the power is shut off to the unit.
9. If the Flame Sensor detects proper flame, the Ignition Control will energize the main gas valve output, which will make the blower to run at a pre-determined high speed until call-for-heat is removed from T-stat.
10. Once the unit is satisfied, the Thermostat will shut off the Blower, Gas Valve and Ignition Control and the unit will be in standby mode until another call for heat is initiated by the thermostat.

# SEQUENCE OF OPERATION – FLOW CHART

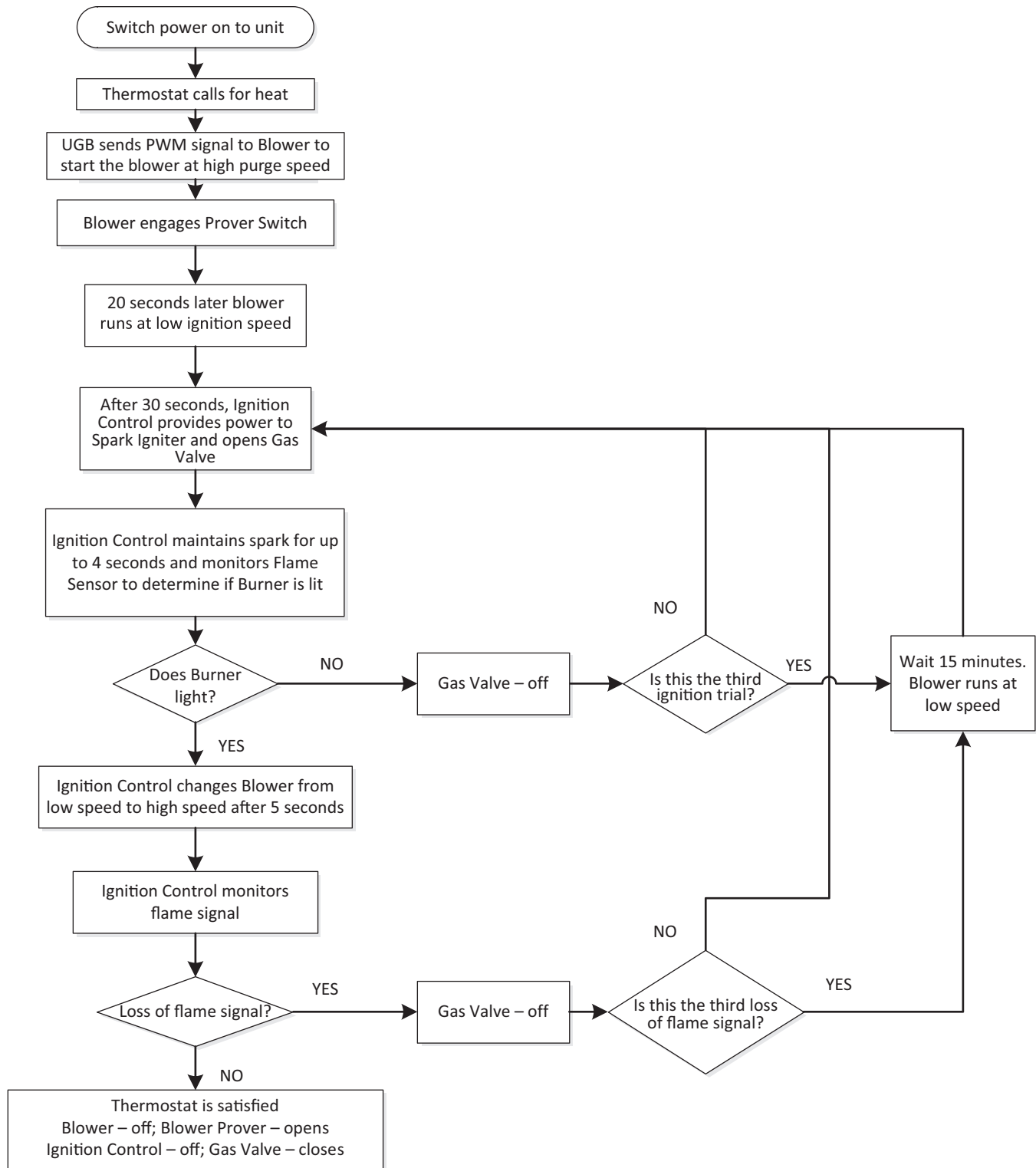

# LIGHTING AND OPERATING LABEL

## FOR YOUR SAFETY READ BEFORE OPERATING



**WARNING:** If you do not follow these instructions exactly, a fire or explosion may result causing property damage, personal injury or loss of life.



**BEFORE OPERATING: ENTIRE SYSTEM MUST BE FILLED WITH WATER AND AIR PURGED FROM ALL LINES.**

- A. This appliance does not have a pilot. It is equipped with an ignition device which automatically lights the burner.  
**Do not try to light the burner by hand.**
- B. BEFORE OPERATING smell all around the area for gas. Be sure to smell next to the floor because some gas is heavier than air and will settle on the floor.
- WHAT TO DO IF YOU SMELL GAS
- Do not try to light any appliance.
  - Do not touch any electric switch; do not use any phone in your building.
  - Immediately call your gas supplier from a neighbor's phone. Follow the gas suppliers instructions.
- If you cannot reach your gas supplier, call the fire department.
- C. Use only your hand to push the control buttons. Never use tools. If the control buttons will not push in, don't try to repair them, call a qualified service technician. Force or attempted repair may result in a fire or explosion.
- D. Do not use this appliance if any part has been under water. Immediately contact a qualified installer or service agency to replace a flooded water heater. Do not attempt to repair the unit. It must be replaced!

## OPERATING INSTRUCTIONS

1. STOP! Read the safety information above on this label.
  2. Set the ON/OFF switch on the control box to the "OFF" position.
  3. Set the thermostat to the lowest setting.
  4. This appliance is equipped with a device which automatically lights the burner.  
**DO NOT TRY TO LIGHT THE BUNER BY HAND.**
  5. Wait five (5) minutes to clear out any gas. If you then smell gas, STOP! Follow "B" in the safety information above on this label. If you don't smell gas, go to the next step.
  6. Turn on all electrical power to the appliance.
  7. Set the ON/OFF switch on the control box to the "ON" position.
  8. Set the thermostat to the desired setting.
  9. If the appliance will not operate, follow the instructions "TO TURN OFF GAS TO APPLIANCE" and call your technician or gas supplier.
- CAUTION: Hotter water increases the risk of scald injury. Consult the instruction manual before changing temperature.**
- WARNING: TURN OFF ALL ELECTRIC POWER BEFORE SERVICING.**

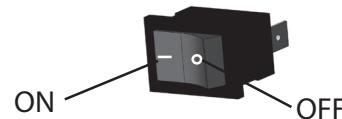

## TO TURN OFF GAS TO APPLIANCE

1. Set the thermostat to the lowest setting.
2. Set the ON/OFF switch on the control box to the "OFF" position.
3. Turn off all electrical power to the appliance if service is to be performed.

## TROUBLESHOOTING

COMPLAINT	CAUSE	REMEDY	
		USER	QUALIFIED AGENCY
*Water not hot enough.	Thermostat set too low.	Set thermostat dial to a higher temperature	
	Upper and/or lower temperature probe out of calibration.	Call qualified agency.	Check continuity and resistance (Ohms) of upper and lower temperature probes. Replace probes if out of specification.
*Insufficient hot water. *See WATER TEMPERATURE CONTROL WARNING on page 12 of Instruction Manual.	Thermostat set too low.	Set thermostat dial to a higher temperature	
	Upper and/or lower temperature probe out of calibration.	Call qualified agency.	Check continuity and resistance (Ohms) of upper and lower temperature probes. Replace probes if out of specification.
	Main manual gas shutoff valve partially closed.	Open main manual gas shutoff valve to fullest extent.	
	Heater too small for demand.	Space usage to give heater time to restore water temperature.	
	Heater recovery is slower.	Call qualified agency.	Check gas input. If incorrect, check for inlet air blockage and/or flue gas exhaust blockage.
Water temperature too hot.	Thermostat set too high.	Set thermostat to a lower setting.	
Rumbling.	Sediment accumulation on bottom of tank.	Drain a quantity of water through drain valve. If rumbling persists, call qualified agency.	Delime heater.
Ticking or metallic sounds.	Expansion and contraction - normal.		
Pounding or water hammer.	Air chambers in piping have become waterlogged. Thermal expansion tank damaged, improperly charged, or improperly sized.	Drain piping system and refill. Heater must be off while this is being done. Check thermal expansion tank charge pressure when the water system pressure is zero.	Follow the manufacturer's instructions for proper charging of the thermal expansion tank.
Water leaks.	Drain valve not closed tightly.	If drain valve cannot be closed tightly, replace.	
	If leakage source cannot be corrected or identified, call qualified agency.	Shut off gas supply to heater and close cold water inlet valve to heater.	Repair or in case of suspected tank leakage, be certain to confirm before replacing heater.
Gas odors.	Possible gas leaks.	Shut off gas supply to heater and call gas company at once.	

## CONTROLS OVERVIEW - CONTROL BOX ASSEMBLY

---

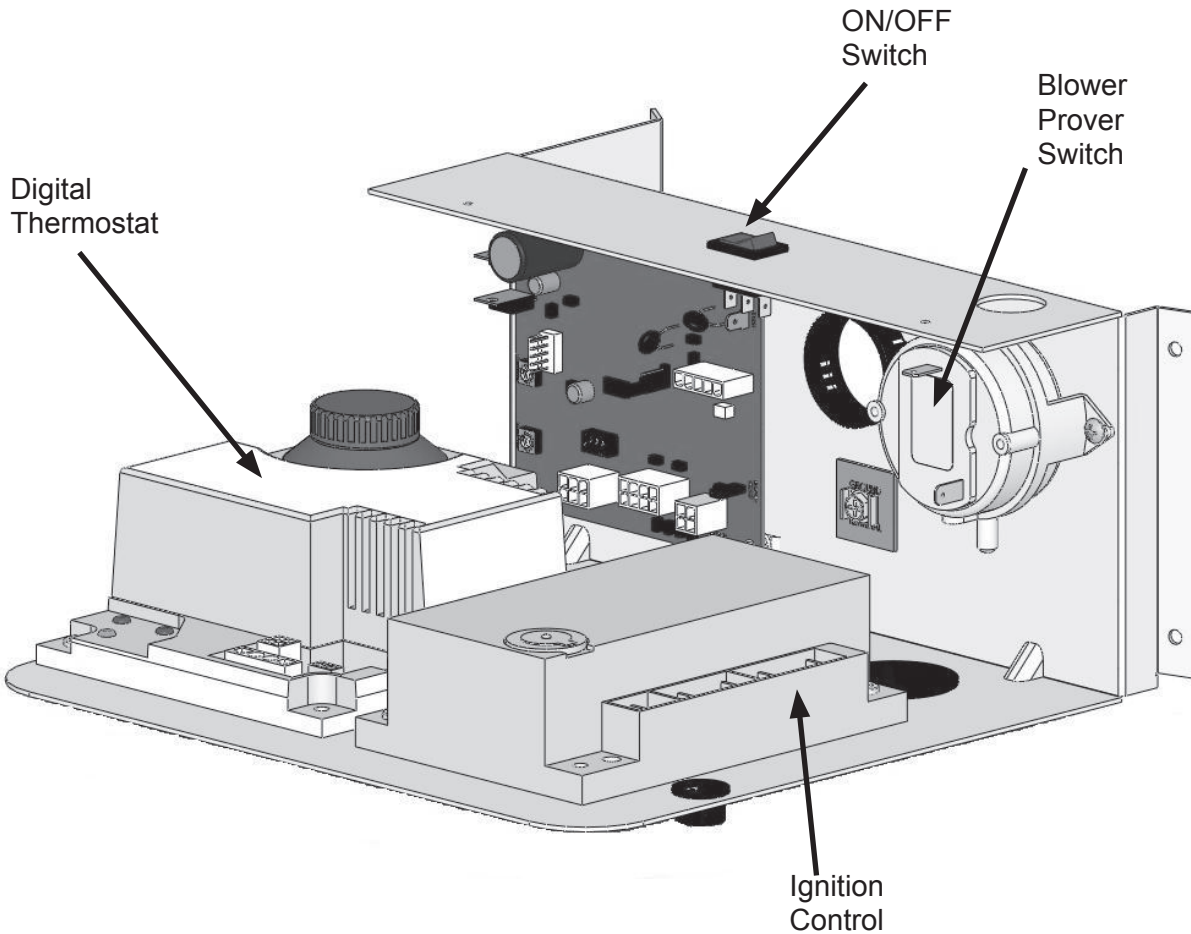

### PRESSURE SWITCHES – ALL MODELS

---

All BCL 120 thru 250 models are provided with one blower prover switch with +0.38" w.c. setpoint. The blower prover switch is provided on the heater to verify that the fan is operating. It is a positive pressure switch whose electrical contacts are normally open. The blower prover switch electrical contacts will close on a rise in pressure as the blower increases the pressure in the burner. This switch is connected to the blower outlet pressure tap by a piece of silicone tubing. This tubing must be connected in order for the switch to close the electrical contacts.

# HIGH LIMIT SWITCH/ DIGITAL THERMOSTAT

The digital thermostat contains the high limit (energy cut out) switch. The high limit switch interrupts burner gas flow should the water temperature reach 203°F (95°C).

In the event of high limit switch operation, the water heater cannot be restarted unless the water temperature is reduced to approximately 120°F (49°C). The manual reset button on the front of the control then needs to be depressed.

Continued manual resetting of high limit control, preceded by higher than usual water temperature is evidence of high limit switch operation.

Contact your dealer or qualified service technician if continued high limit switch operation occurs.

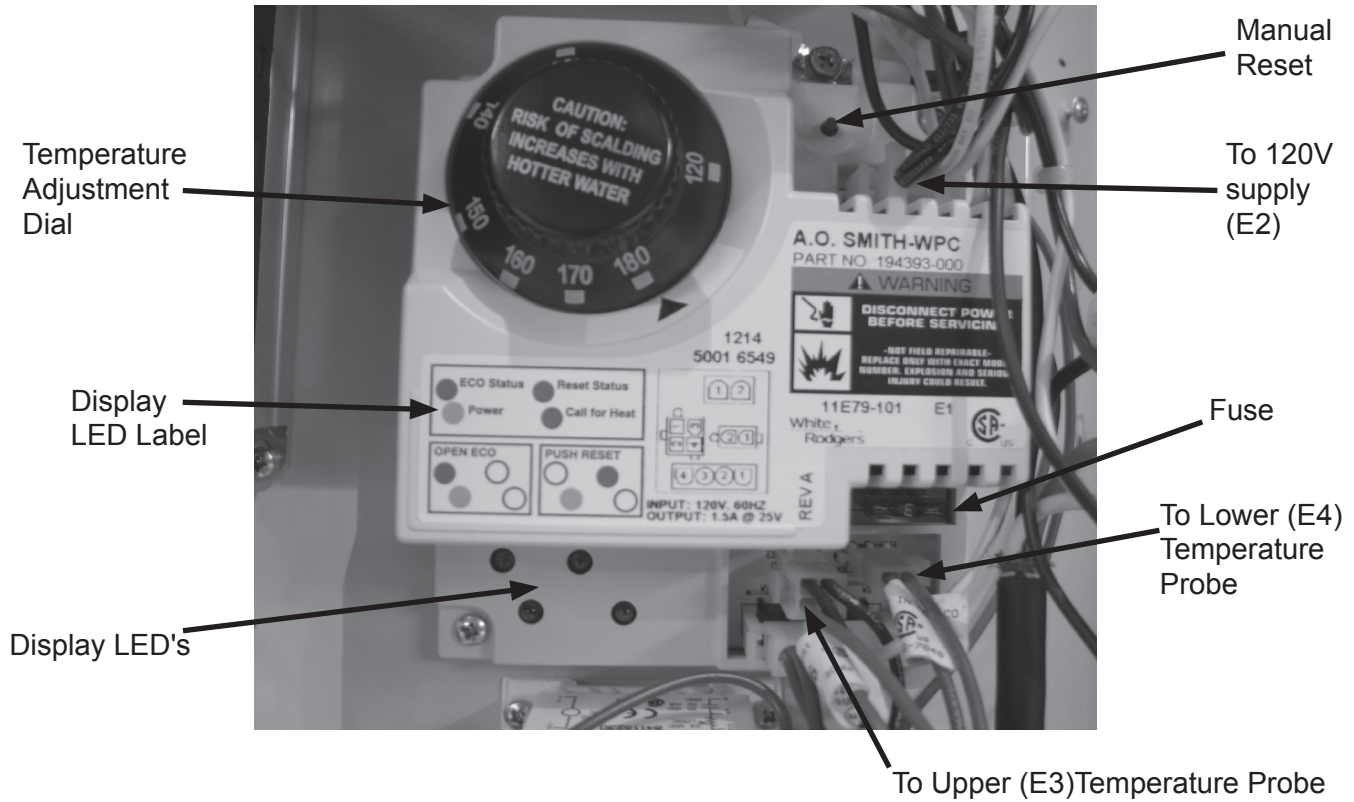



## DISPLAY LIGHTS – DIGITAL THERMOSTAT

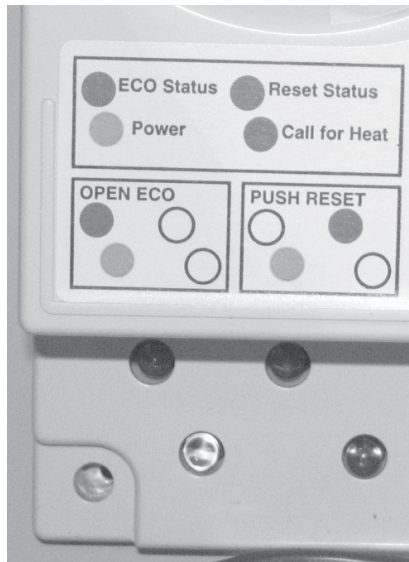

LED STATUS	INDICATION	ACTION
	Calling for heat	Normal status. No action required.
	The ECO (Energy Cut-Out) has opened.	<ul style="list-style-type: none"> <li>• Check for excessively hot water (203° F or higher).</li> <li>• Check the resistance of the temperature probes and continuity of the high limit (ECO).</li> </ul>
	No power	Check the breaker.
	Tank is at a set temperature $\pm 2^{\circ}$ F.	No action required.
	Tank has cooled below 120° F. Preceded by “ECO Open” indication.	<ul style="list-style-type: none"> <li>• Push the manual reset button.</li> <li>• Check the resistance of the temperature probes and continuity of the high limit (ECO).</li> </ul>

## CONTINUITY CHECK OF HIGH LIMIT (ECO)

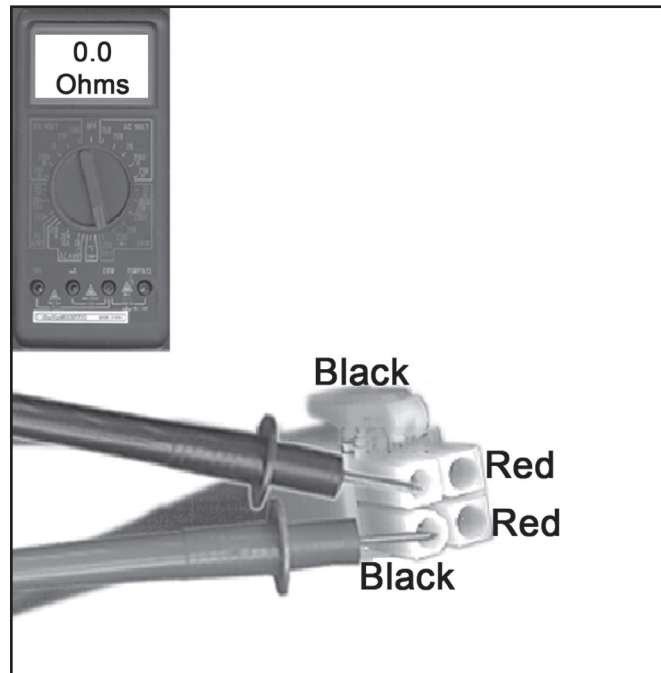

### CONDITIONS:

- Power On – No Hot Water.
- Red, digital thermostat “Call for Heat” LED – On.
- Turn Power OFF.

Continuity check of ECO (energy cut-out, high limit) Black to Black wires of upper probe. Power is off.	
IF.....	THEN.....
Continuity is indicated (ZERO “0.0” Resistance)	Opens at 203° F; closes at 193° F. If water is below 193° F, continuity is correct.
Continuity is not present (meter reads “0.L”)	Replace ECO sensor, if water temperature is below 193° F.
Water is less than 120° F	<ul style="list-style-type: none"> <li>• Reset status LED should be on.</li> <li>• Replace digital thermostat if control will not manually reset.</li> </ul>

# UPPER TEMPERATURE PROBE CONTINUITY CHECK

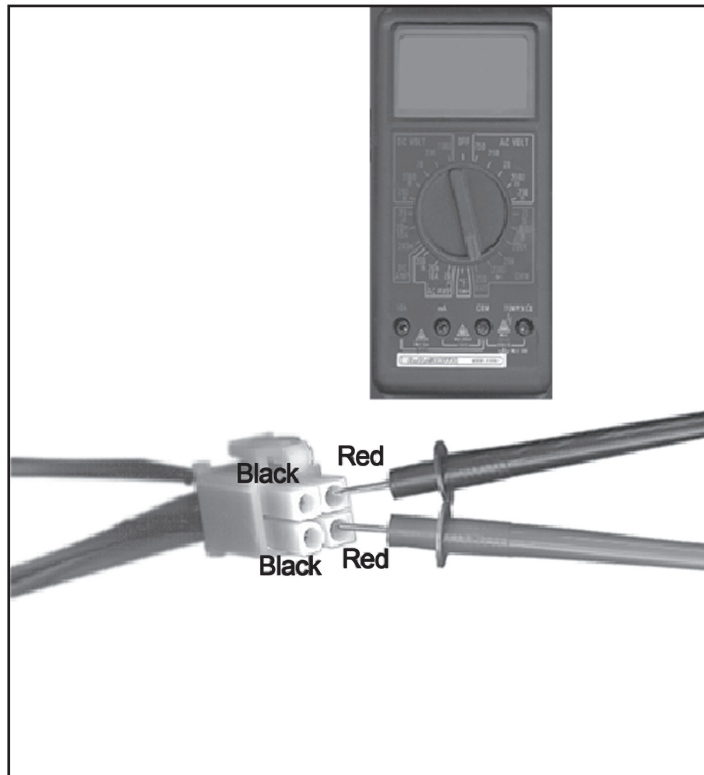

## CONDITIONS:

- Power On – Water below temperature set point.
- Red, digital thermostat “Reset Status” LED – OFF.
- "Call for Heat" LED Off.

## OHMS RESISTANCE TABLE

° F	OHMS
70°	11,884
120°	3,759
140°	2,488
180°	1,169

Upper Temperature Probe continuity check Red wire to red wire – Turn supply power "Off" for this test.	
IF.....	THEN.....
Test indicates <b>no continuity</b> .	Replace probe.
<b>Continuity</b> is indicated.	Probe should be okay (also verify Ohms resistance for water temperature). (Reading will be approximate.)

## LOWER TEMPERATURE PROBE CONTINUITY CHECK

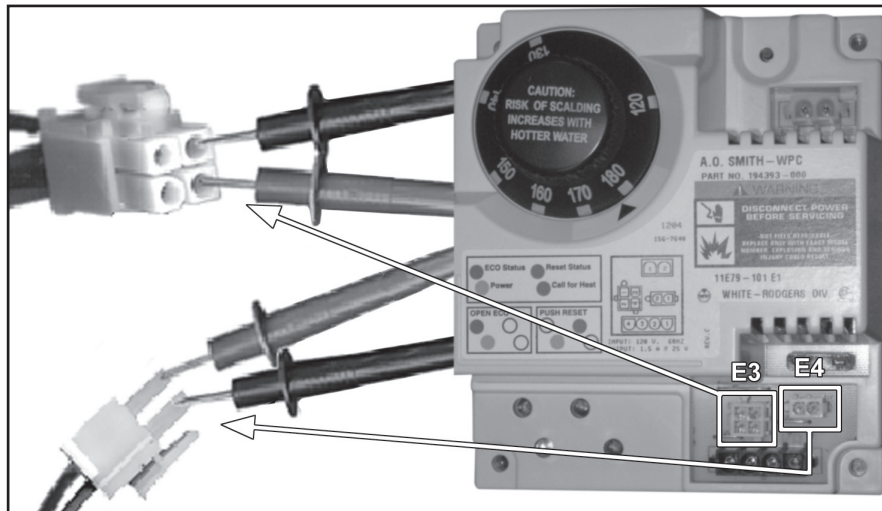

### CONDITIONS:

- Main burner ignited.
- Stored water is below temperature setting more than 5° F (Tank Average).
- Power Off.
- Plug disconnected from digital thermostat receptacle E4.

### OHMS RESISTANCE TABLE

° F	OHMS
70°	11,884
120°	3,759
140°	2,488
180°	1,169

Lower Temperature Probe continuity check	
Red wire to red wire – Turn supply power "Off" for this test.	
IF.....	THEN.....
Test indicates <b>no continuity</b> .	Replace probe.
<b>Continuity</b> is indicated.	Probe should be okay (also verify Ohms resistance for water temperature). (Reading will be approximate.)

## IGNITION CONTROL

Each heater is equipped with an ignition control. The solid state ignition control, ignites the burner by utilizing a spark igniter. The spark igniter shuts off during the heating cycle and the burner flame is sensed through a remote flame sensor.

The ignition control will try to ignite the burner three times before lockout. The control waits 15 minutes before trying again to ignite the burner. This is a continuous cycle.

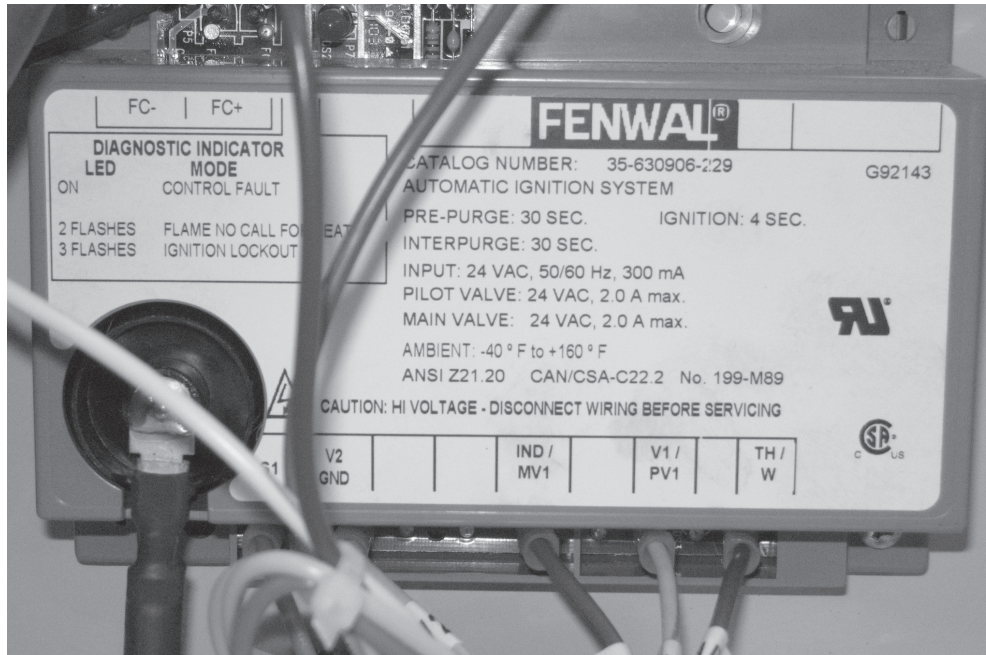

This is a 24 VAC ignition control. The microprocessor circuit design provides precise, repeatable timing and operating sequences. The on-board diagnostics with LED output make troubleshooting easy and ensures safe and efficient operation.

### WIRING TERMINALS

TERMINAL	DESCRIPTION
TH/W	Thermostat Input
PV1	Gas Valve Power
MV1	UGB High Speed Control Signal
V2	Valve Ground
GND	System Ground
S1	Remote Flame Sensor
HV	High Voltage Output

## **START UP/ FLAME RECOVERY/ SAFETY LOCKOUT**

---

### **START UP - HEAT MODE**

When a call for heat is received from the thermostat supplying 24 volts to UGB J5.6, the UGB will enable blower run at prepurge speed, which will cause the blower prover switch closing, and allow 24vac power from the T-stat to TH/W terminal of the control module. The control will reset, perform a self check routine, flash the diagnostic LED once in the first two seconds, and a pre-purge delay begins. 20 seconds after high speed prepurge, UGB will send a ignition low speed PWM to blower for preparing the ignition sequence. Following the 30 seconds pre-purge period, the gas valve is energized and sparks commence for the trial for ignition period.

When flame is detected during the trial for ignition, the sparking process is terminated and the UGB high speed signal is energized after a 5 second dwell period and the heater will run at the rated fire rate. The thermostat and burner flame are constantly monitored to assure the system continues to operate properly. When the thermostat is satisfied and the demand for heat ends, the gas valve and UGB speed signals are de-energized immediately.

### **FAILURE TO LIGHT - LOCKOUT**

#### **MULTI TRIAL CONTROL**

Should the burner fail to light, or if flame is not detected during the first trial for ignition period, the gas valve is de-energized. The control then goes through an interpurge delay before another ignition attempt. The control will attempt two additional ignition trials before going into lockout and the valve relay will be de-energized immediately. This ignition control has an automatic reset. If the thermostat is still calling for heat after 15 minutes the control will automatically reset and attempt to ignite the burner.

#### **FLAME FAILURE- RECYCLE MODE**

This control has the "recycle after loss of flame" function, upon loss of an established burner flame, the gas valve is de-energized and the control proceeds to interpurge before attempting to relight the burner. The ignition control will allow three tries for ignition including inter-purges. If the burner relights, normal operation resumes. If the burner does not relight, the control will go into lockout as described in "failure to light".

## FAULT CONDITIONS

The water heater is equipped with an ignition control that incorporates a diagnostic system to assist in troubleshooting the appliance. The indicator codes on the ignition module are as follows:

LED INDICATION	FAULT MODE
2 Flashes	Flame sensed without call for heat.
3 Flashes	Ignition Lockout.
Steady On	Internal Control Failure

The LED will flash on for 1/4 second, then off for 1/4 second during a fault condition. The pause between fault codes is 3 seconds.

## INTERNAL CONTROL FAILURE

If the ignition control detects an error in its software or hardware, all outputs are turned off and the LED displays a steady ON condition. If an internal control failure is indicated, replace the ignition control.

## TROUBLESHOOTING GUIDE FOR IGNITION CONTROL

SYMPTOMS	CAUSES
1. Control does not start	a. Miswired. b. No 24V AC power supply at TH/W terminal. c. Bad control, check LED for steady on or flashing code (see above Table).
2. Thermostat on -no spark	a. Miswired. b. No 24V AC power supply at TH/W terminal. c. Bad control, check LED for steady on or flashing codes.
3. Valve on - no spark during TFI	a. Shorted electrode -establish 1/8 inch gap. b. Check high voltage cable. c. Miswired.
4. Spark on - valve off	a. Valve coil open. b. Valve wire disconnected. c. Bad control, check voltage at gas valve terminals PV1 and V2.
5. Flame okay during TFI - no flame sense after TFI	a. Poor ground at burner. b. Poor flame, check flame current. c. Check flame rod position.

## FLAME SENSOR CURRENT CHECK

Flame current is the current that passes through the flame from the sensor to ground. The minimum flame current necessary to keep the system from lockout is 0.7 micro amps. To measure flame current, connect analog DC microammeter to the FC-, FC+ terminals on the Ignition Control. Meter should read 0.7 microamps or higher. If the meter reads below "0" on scale, meter leads are reversed; disconnect power and reconnect meter leads for proper polarity.



## UGB – BLOWER SPEED CONTROL

The BCL 120 thru 250(A) models are equipped with a UGB PWM output control board for blower speed control. When the UGB J5.6 is energized by T-stat Call-for-heat, the UGB will provide 90% duty cycle PWM signal to the blower for 20 seconds prepurge, then provide a PWM control signal per SW2 dipswitch setting for ignition speed. After the flame is confirmed and the UGB J5.3 is energized by the main gas control of the ignition module, the UGB will provide a high blower speed control per SW4 dipswitch setting. For the detailed SW2 and SW4 dipswitch settings of different BCL models, see the dipswitch table listed in this page.

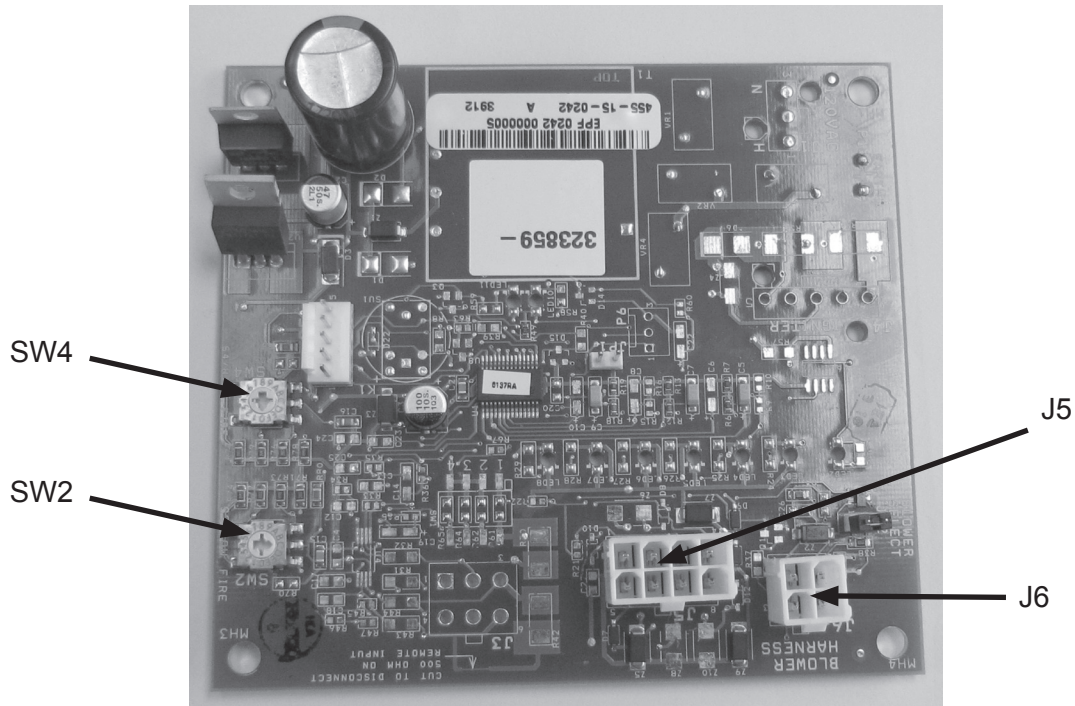

PART NO.	SW2	SW4	USED FOR
323859-000	7	2	BCL381T1206NOX
323859-001	8	B	BCL381T1546NOX
323859-002	6	A	BCL395T1806NOX
323859-003	3	3	BCL395T1996NOX
323859-004	3	8	(A)BCL395T2506NOX

PIN CONNECTIONS		
	PIN NUMBER	DESCRIPTION
J5	J5.5	24VAC H
	J5.1	24VAC N
	J5.6	ENABLE
	J5.3	HIGH FIRE
	J5.2, 5.4, 5.7, 5.8	NOT USED
J6	J6.1	24VDC H
	J6.2	24VDC RTN
	J6.3	NOT USED
	J6.4	PWM OUTPUT

# WIRING DIAGRAM

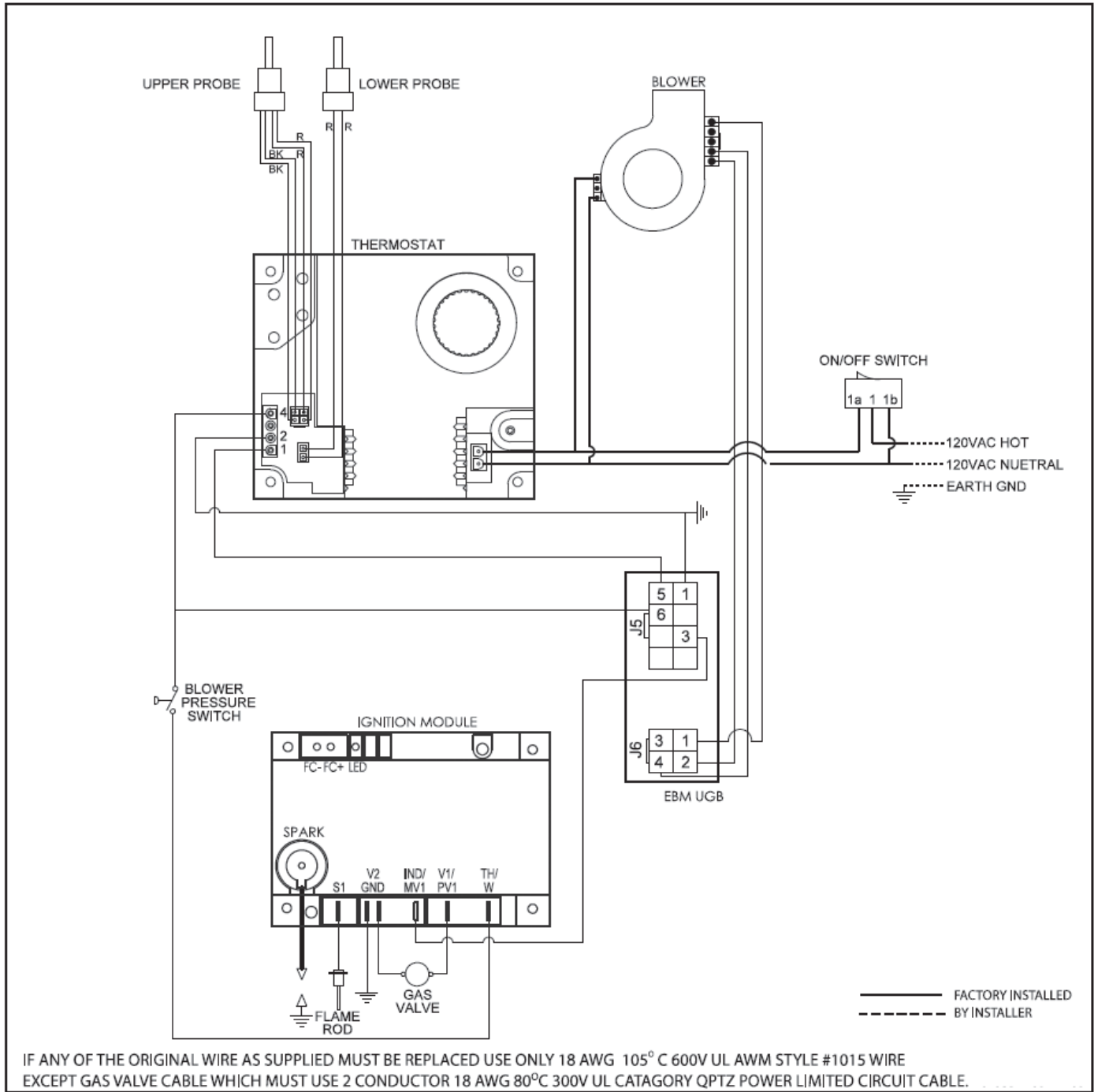

# COMMERCIAL GAS WATER HEATERS

Visit the "Information Central" link of [www.americanwaterheater.com](http://www.americanwaterheater.com) for a listing of available Service Handbooks.

For additional information contact:

**American Water Heaters**

PO Box 1597, 500 Princeton Road

Johnson City, TN 37605

1-800-456-9805

[www.americanwaterheater.com](http://www.americanwaterheater.com)