

6-Year Limited Tank/Parts Warranty*

American® Direct Vent residential gas water heaters offer horizontal or vertical venting options in an FVIR solution to reduce the risk of accidental fires involving flammable vapors.

- **Flammable Vapor Resistant/Direct Vent Sealed Combustion System**

Thru-the-Wall/Thru-the-Roof venting of combustion products. Air for combustion is drawn from outside the building.

- **Fused Ceramic Tank Shield**

A tough, thick, durable coat of blue ceramic is fused to the tank's interior surfaces at 1600°F, forming a corrosion-resistant lining for years of dependable protection and use.

- **Non-CFC Foam Insulation**

The tank is surrounded by a thick coat of non-CFC polyurethane foam to trap heat inside the tank, saving energy.

- **CSA Certified and ASME Rated T&P Relief Valve**

Conveniently located on the side of the tank to facilitate piping to a drain or external to the building.

- **3/4" Top Water Connections and Side Space Heating Connections**

- **1/2" Gas Connection**

- **Aluminized Steel Multiport Burner**

For even flame distribution, quiet operation and high-efficiency combustion. Propane models feature cast iron burners.

- **Combination Thermostat/ECO**

With factory-preset pressure regulator and built-in millivolt-powered energy cut-off for overheat protection.

- **Anode Rod**

Top-mounted, heavy-duty anode for added tank protection, extending the life of the tank.

- **Code Approvals**

Tested and listed with CSA International in accordance with the latest addition of ANSI Z21.10.1 - 4.1 CSA Standards, CEC and 2004 NAECA approved. All models are certified at 300 PSI test pressure and 150 PSI working pressure.

- **Drain Valve**

Child-resistant, corrosion-resistant drain valve.



*For complete warranty information consult the written warranty of American Water Heaters found at www.americanwaterheater.com, or call (800) 999-9515.

This dimension is 5" on both 40 and 50-gallon models from the outside surface of the Jacket to the outside edge of the Top Air Supply Box.

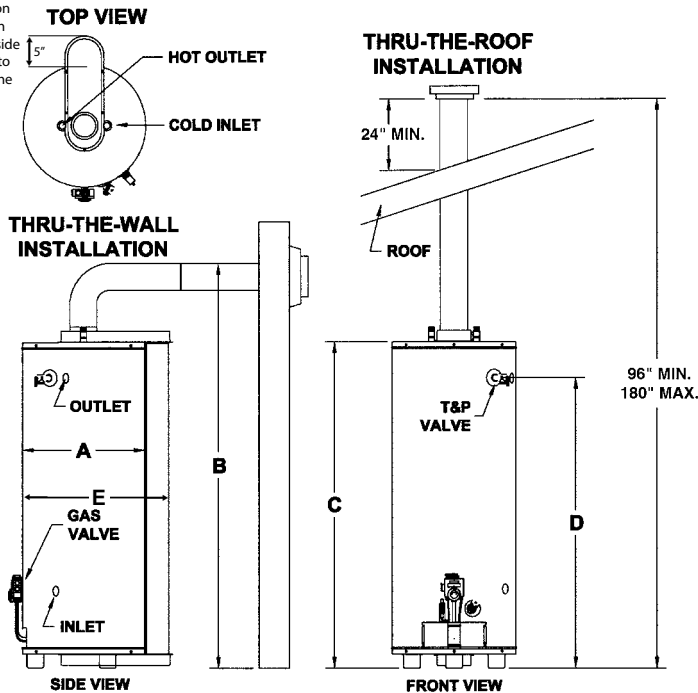

THRU-THE-WALL VENTING

Horizontal Extension Kits:

	Min.	Max.
Std. Kit #6907180	4.75"	13.5"
Opt. Kit #6907171	16.0"	27.0"

Measured from the water jacket to the outside wall. Only one vertical and one horizontal extension kit can be used at the same time.

Vertical Extension Kits:

	40 Gal.	50 Gal.
Std. Hgt.	65.25"	73.50"
Max. Hgt.	92.25"	100.5"
Opt. Kit #	6907173	6907172

Measured from the floor to the top of the 5-inch elbow

THRU-THE-ROOF VENTING

	Min.	Max.	Part Number
Std. Kit	96.0"	180.0"	6907344

Measured from the floor to the bottom of vent terminal. See installation and service manual for more information.

Residential Gas Direct Vent

MODEL NUMBER	GAL. CAP.	INPUT BTU PER HR.		GPH RECOVERY 90° RISE		VENT DIAM.	E.F.	JACKET DIAM. A	HEIGHT			Depth Incl. Vent E	APPROX. SHIP WEIGHT
		NAT.	LP	NAT.	LP				TOP OF VENT B	TOP OF HEATER C	SIDE T&P D		
		DVG62-40S38-NV	40	38,000	36,000				38.5	36.5	N/A		
DVG62-50T42-NV	50	42,000	40,000	42.6	40.5	N/A	0.58	22	73-1/2	58-1/2	52-1/4	27	193

No option available for top T&P valve. Dimensions and specifications subject to change without notice in accordance with our policy of continuous product improvement. Dimensions on all charts shown in inches. All units have 3/4" top water connections, 1/2" gas connections. Side connections are located on the right side of heater. For propane, substitute "P" for "N" in model numbers.

Specification

Residential gas water heater(s) shall be model _____ as manufactured by American Water Heaters, or an approved equal, and shall have a _____-year tank warranty and a _____-year parts warranty, when installed in a residential application. Heater(s) shall have a storage capacity of _____ gallons and shall have a rated input of _____ BTU's, and shall be designed, tested and listed with CSA International in accordance with the latest edition of ANSI Z21.10.1 - CSA 4.1 Standards. Heaters shall meet or exceed the Federal Energy Efficiency Standards effective January 20, 2004, according to the National Appliance Energy Conservation Act (NAECA) of 1992. The interior of the storage tank shall be lined with a Fused Ceramic Shield lining, fused to the tank at 1600° F, forming a corrosion-resistant lining; polymer linings are not acceptable. Each tank shall be furnished with an internal anode for cathodic protection. The unit must be equipped with a combination gas control thermostat and non-reset type ECO. A corrosion-resistant drain valve shall be provided on the front of each unit. The tank shall be totally encased in a steel jacket, painted and insulated with a non-CFC foam to reduce standby heat loss. The tank must be design certified for 300 PSI test pressure and 150 working pressure.

Distributed By:

Order Entry and Sales

500 Princeton Road (FEDEX, UPS)
Johnson City, TN 37601-2030
P.O. Box 4808 (Mailing)
Johnson City, TN 37602-4808
(800) 937-1037
FAX (800) 581-7224

Warranty and Service

500 Princeton Road (FEDEX, UPS)
Johnson City, TN 37601-2030
P.O. Box 1597 (Mailing)
Johnson City, TN 37605-1597
(800) 999-9515
FAX (800) 999-5210