

MODELS BBCN375T754NV

Series 100

COMMERCIAL ULTRA LOW NO_x GAS WATER HEATER Glass-Lined Tank-type Water Heater

• INSTALLATION • OPERATION • SERVICE • MAINTENANCE • LIMITED WARRANTY



GAS-FIRED



Low Lead Content



WARNING: If the information in these instructions is not followed exactly, a fire or explosion may result causing property damage, personal injury or death.

- Do not store or use gasoline or other flammable vapors and liquids in the vicinity of this or any other appliance.
- WHAT TO DO IF YOU SMELL GAS
 - Do not try to light any appliance.
 - Do not touch any electrical switch; do not use any phone in your building.
 - Immediately call your gas supplier from a neighbor's phone. Follow the gas supplier's instructions.
 - If you cannot reach your gas supplier, call the fire department.
- Installation and service must be performed by a qualified installer, service agency or the gas supplier.



CAUTION
TEXT PRINTED OR OUTLINED IN RED CONTAINS INFORMATION RELATIVE TO YOUR SAFETY. PLEASE READ THOROUGHLY BEFORE INSTALLING AND USING THIS APPLIANCE.



www.americanwaterheater.com

American Water Heater
Johnson City, TN 37605

PLACE THESE INSTRUCTIONS ADJACENT TO HEATER
AND NOTIFY OWNER TO KEEP FOR FUTURE REFERENCE.

ROUGH-IN DIMENSIONS

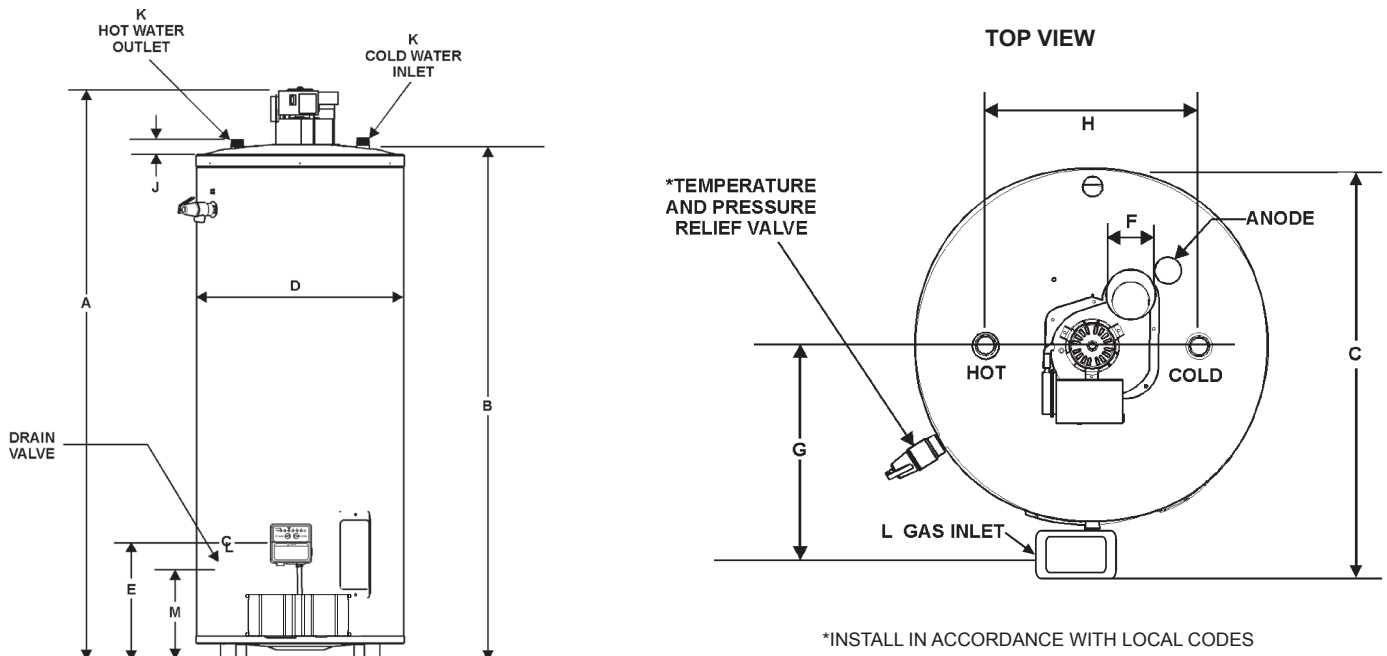

FIGURE 1.

TABLE 1, DIMENSIONS

Units	A	B	C	D	E	F	G	H	J	K	L	M
Inches	66 5/8	58 3/4	30 15/16	27 3/4	15 1/4	4	15 3/4	16	1 1/4	1 1/4	1/2	12 1/4
CM	169.22	134.23	78.58	70.5	38.6	10.2	40.0	40.6	3.2	NPT	NPT	31.1

TABLE 2, RECOVERY RATINGS

INPUT RATE	Recovery in US Gallons/hr or Liters/hr at Indicated Temperature Rise in Fahrenheit or Celsius												
	°F	30	40	50	60	70	80	90	100	110	120	130	140
75,100 BTU/H	GPH	243	182	145	122	104	91	81	73	66	60	56	52
	°C	17	23	28	33	39	44	50	56	61	67	72	78
22 KW	LPH	920	688	549	460	392	344	306	277	251	228	213	199

Recovery ratings are based on 80% thermal efficiency.

TABLE 3, GAS AND ELECTRICAL CHARACTERISTICS

Manifold Pressure			Electrical Characteristics	
Type of gas	Inches W.C.	kPa	Voltz/Hz	Amperes
Natural Gas	4.0	1.12	120/160	<5

All Models: Maximum supply pressure = 14.0 in. W.C. (3.48 kPa)
 Minimum supply pressure, Natural gas = 6 in. W.C. (1.49 kPa).
 Minimum pressures must be maintained under both load and no load (static and dynamic) conditions.

FOREWORD

The design of model BBCN375T754NV complies with the current edition of ANSI Z21.10.3/CSA 4.3 as automatic storage or automatic circulating tank type water heaters.

Installation diagrams are found in this manual. These diagrams will serve to provide the installer with a reference for the materials and method of piping necessary. It is highly essential that all water and gas piping be installed as shown on the diagrams.

In addition to these instructions, the equipment shall be installed in accordance with those installation regulations in force in the local area where the installation is to be made. These shall be carefully followed in all cases. Authorities having jurisdiction should be consulted before installations are made.

The installation must conform to these instructions and the local code authority having jurisdiction.

In the absence of local codes, the installation must comply with the following:

In the United States:

Current edition of the National Fuel Gas Code, ANSI Z223.1 / NFPA 54 and the National Electrical Code, NFPA 70;

In Canada:

Current edition of the Installation Code CAN/CSA-B149.1 and the Canadian Electrical Code CSA C22.1.

These are available from Canadian Standards Association, 8501 East Pleasant Valley Road, Cleveland, OH 44131 or National Fire Protection Association, 1 Batterymarch Park, Quincy, MA 02269.

TABLE OF CONTENTS

	Page		Page
ROUGH-IN DIMENSIONS.....	2	To Operate The Heater	9
FOREWORD	2	Lighting Instructions.....	10
GENERAL SAFETY INFORMATION.....	2-4	Temperature Regulation	11
Precautions.....	3	Checking Venting.....	11
Grounding Instructions.....	3	High Temperature Limit Switch	11
Chemical Vapor Corrosion.....	3	SERVICE INFORMATION	12-13
Extended Non-use Periods.....	3	Main Burner and Igniter	12
Insulation Blankets.....	4	Checking Gas Input	12
High Altitude Installations.....	4	Vent System.....	12
Circulating Pump	4	Blower Maintenance	13
INSTALLATION INSTRUCTIONS	4-9	Relief Valve	13
Required Ability.....	4	Hot Water Odor.....	13
Locating The Heater	4	Winter Protection	13
Clearances.....	5	Replacement Parts	13
Hard Water	5	PREVENTIVE MAINTENANCE.....	13-14
Air Requirements.....	5	Procedure for Periodic Removal Of Lime Deposits	13
Venting.....	6	Deliming Solvents	13
Thermometers (Not Supplied)	7	Tank Cleanout Procedure	14
Combination Water (Potable) Heating and Space Heating	7	CHECKLIST	15-16
Relief Valve.....	7	Condensation.....	15
Gas Piping.....	7	Anode	15
Heater Wiring.....	8	Service & Repair.....	16
Wiring Diagram	8	TROUBLESHOOTING	17-20
Purging	9	NOTES	21-22
Gas Pressure Regulation.....	9	LIMITED WARRANTY	23
OPERATION.....	9		

GENERAL SAFETY INFORMATION

PRECAUTIONS

DO NOT USE THIS WATER HEATER IF ANY PART HAS BEEN UNDER WATER. Immediately call a qualified service technician to inspect the appliance and to replace any part of the control system and any gas control which has been under water.

IF THE UNIT IS EXPOSED TO THE FOLLOWING, DO NOT OPERATE HEATER UNTIL ALL CORRECTIVE STEPS HAVE BEEN MADE BY A QUALIFIED SERVICEMAN.

1. EXTERNAL FIRE.
2. DAMAGE.
3. FIRING WITHOUT WATER.
4. SOOTING.

Heater must be protected from freezing downdrafts during shutdown periods.

GROUNDING INSTRUCTIONS

This water heater must be grounded in accordance with the National Electrical Code and/or local codes. These must be followed in all cases.

This water heater must be connected to a grounded metal, permanent wiring system; or an equipment grounding conductor must be run with the circuit conductors and connected to the equipment grounding terminal or lead on the water heater, see Figure 5.

CHEMICAL VAPOR CORROSION

WARNING

CORROSION OF THE FLUEWAYS AND VENT SYSTEM MAY OCCUR IF AIR FOR COMBUSTION CONTAINS CERTAIN CHEMICAL VAPORS. SUCH CORROSION MAY RESULT IN FAILURE AND RISK OF ASPHYXIATION.

Spray can propellants, cleaning solvents, refrigerator and air conditioning refrigerants, swimming pool chemicals, calcium and sodium chloride (water softener salt), waxes, and process chemicals are typical compounds which are potentially corrosive. Do not store products of this sort near the heater. Also, air which is brought in contact with the heater should not contain any of these chemicals. If necessary, uncontaminated air should be obtained from remote or outside sources. The limited warranty is voided when failure of water heater is due to a corrosive atmosphere. (Refer to the limited warranty for complete terms and conditions.)

EXTENDED NON-USE PERIODS

WARNING

HYDROGEN GAS CAN BE PRODUCED IN A HOT WATER SYSTEM SERVED BY THIS HEATER THAT HAS NOT BEEN USED FOR A LONG PERIOD OF TIME (GENERALLY TWO WEEKS OR MORE). HYDROGEN GAS IS EXTREMELY FLAMMABLE. To reduce the risk of injury under these conditions, it is recommended that the hot water faucet be opened for several minutes at the kitchen sink before using any electrical appliance connected to the hot water system. If hydrogen is present, there will probably be an unusual sound such as air escaping through the pipe as the water begins to flow. **THERE SHOULD BE NO SMOKING OR OPEN FLAME NEAR THE FAUCET AT THE TIME IT IS OPEN.**

INSULATION BLANKETS

Insulation blankets available to the general public for external use on gas water heaters are not required for use on your water heater. The purpose of an insulation blanket is to reduce the standby heat loss encountered with storage tank water heaters. Your water heater meets or exceeds the current edition of ASHRAE/IES 90.1 standards with respect to insulation and standby loss requirement making an insulation blanket unnecessary.

WARNING

Should you choose to apply an insulation blanket to this heater, you should follow these instructions. Failure to follow these instructions can result in fire, asphyxiation, serious personal injury or death.

- **Do not** apply insulation to the top of the water heater, as this will interfere with safe operation.
- **Do not** cover the outer door, thermostat or temperature & pressure relief valve.
- **Do not** allow insulation to come within 2" (5cm) of the floor to prevent blockage of combustion air flow to the burner.
- **Do not** cover the instruction manual. Keep it on the side of the water heater or nearby for future reference.
- **Do** obtain new warning and instruction labels from the manufacturer for placement on the blanket directly over the existing labels.
- **Do** inspect the insulation blanket frequently to make certain it does not sag, thereby obstructing combustion air flow.

HIGH ALTITUDE INSTALLATIONS

Water heaters covered in this manual have been tested and approved for installation at elevations up to 7,700 feet (2,347 m) above sea level. For installation above 7,700 feet (2,347 m), the water heater's Btu input should be reduced at the rate of 4 percent for each 1,000 feet (305 m) above sea level which requires replacement of the burner orifice in accordance with the National Fuel Gas Code ANSI Z223.1/ NFPA 54. Contact your local gas supplier for further information.

Failure to replace the standard orifice with the proper high altitude orifice when installed at elevations above 7,700 feet (2,347 m) could result in improper and inefficient operation of the water heater, producing carbon monoxide gas in excess of the safe limits. This could result in serious injury or death. Contact your local gas supplier for any specific changes that may be required in your area.

Upon completion of derating of the heater, adjustment to the gas pressure regulator may be required. See CHECKING THE

INPUT section in this manual for inlet and manifold pressure requirements.

Also due to the input rating reduction required at high altitudes, the output rating of the appliance is also reduced and should be compensated for in the sizing of the equipment for application.

CIRCULATING PUMP

A circulating pump is used when a system requires a circulating loop or there is a storage tank used in conjunction with the heater. Refer to the piping diagrams at rear of manual for electrical hookup information and install in accordance with the current edition of the National Electrical Code ANSI/NFPA No. 70. In Canada refer to Canadian Electrical Code CSA C22.1.

Only all bronze circulating pumps are used with commercial water heaters. Although circulators are oiled and operated by the manufacturer some circulators must be oiled again before operating. Please refer to manufacturer's instructions.

INSTALLATION INSTRUCTIONS

REQUIRED ABILITY

INSTALLATION OR SERVICE OF THIS WATER HEATER REQUIRES ABILITY EQUIVALENT TO THAT OF A LICENSED TRADESMAN IN THE FIELD INVOLVED. PLUMBING, AIR SUPPLY, VENTING, ELECTRICAL AND GAS SUPPLY WORK ARE REQUIRED.

LOCATING THE HEATER

WARNING

THERE IS A RISK IN USING FUEL BURNING APPLIANCES SUCH AS GAS WATER HEATERS IN ROOMS, GARAGES OR OTHER AREAS WHERE GASOLINE, OTHER FLAMMABLE LIQUIDS OR ENGINE DRIVEN EQUIPMENT OR VEHICLES ARE STORED, OPERATED OR REPAIRED. FLAMMABLE VAPORS ARE HEAVY AND TRAVEL ALONG THE FLOOR AND MAY BE IGNITED BY THE HEATER'S PILOT OR MAIN BURNER FLAMES CAUSING FIRE OR EXPLOSION. SOME LOCAL CODES PERMIT OPERATION OF GAS APPLIANCES IF INSTALLED 18 INCHES (45.7 CM) OR MORE ABOVE THE FLOOR. THIS MAY REDUCE THE RISK IF LOCATION IN SUCH AN AREA CANNOT BE AVOIDED.

DO NOT INSTALL THIS WATER HEATER DIRECTLY ON A CARPETED FLOOR. A FIRE HAZARD MAY RESULT. Instead the water heater must be placed on a metal or wood panel extending beyond the full width and depth by at least 3 inches (7.6 CM) in any direction. If the heater is

installed in a carpeted alcove or closet, the entire floor shall be covered by the panel. Also, see the drain requirements.

THIS HEATER SHALL BE LOCATED OR PROTECTED SO IT IS NOT SUBJECT TO PHYSICAL DAMAGE BY A MOVING VEHICLE.

⚠ WARNING

FLAMMABLE ITEMS, PRESSURIZED CONTAINERS OR ANY OTHER POTENTIAL FIRE HAZARDOUS ARTICLES MUST NEVER BE PLACED ON OR ADJACENT TO THE HEATER. OPEN CONTAINERS OF FLAMMABLE MATERIAL SHOULD NOT BE STORED OR USED IN THE SAME ROOM WITH THE HEATER.

When installing the heater, consideration must be given to proper location. Location selected should be as close to the stack or chimney as practicable, with adequate air supply and as centralized with the piping system as possible.

THE HEATER MUST NOT BE LOCATED IN AN AREA WHERE IT WILL BE SUBJECT TO FREEZING.

THE HEATER SHOULD BE LOCATED IN AN AREA WHERE LEAKAGE FROM THE HEATER OR CONNECTIONS WILL NOT RESULT IN DAMAGE TO THE ADJACENT AREA OR TO LOWER FLOORS OF THE STRUCTURE.

WHEN SUCH LOCATIONS CANNOT BE AVOIDED, A SUITABLE DRAIN PAN SHOULD BE INSTALLED UNDER THE HEATER. Such pans should be fabricated with sides at least 2" (5cm) deep, with length and width at least 2" (5cm) greater than the diameter of the heater and must be piped to an adequate drain. The pan must not restrict combustion air flow.

Drain pans suitable for these heaters are available from the manufacturer, authorized service agencies or distributors.

CLEARANCES

These heaters are approved for installation on combustible flooring in a closet having a ceiling 12" (30.5cm) above top cover and with clearances to combustible construction of 6" (15.2cm) from flue or vent connector, 0" (0cm) at the sides and rear and 5" (10.2cm) to front to prevent a possible fire hazard condition. A minimum of 4" (10.2cm) shall be allowed for installation of serviceable parts.

HARD WATER

Where hard water conditions exist, water softening or the threshold type of water treatment is recommended. This will protect the dishwashers, coffee urns, water heaters, water piping and other equipment.

See MAINTENANCE section for details of tank cleanout procedure.

AIR REQUIREMENTS

REFER TO CURRENT EDITION OF THE "NATIONAL FUEL GAS CODE ANSI Z223.1/NFPA 54. FOR CANADA CONSULT CAN/CSA-B149.1.

KEEP APPLIANCE AREA CLEAR AND FREE OF COMBUSTIBLE MATERIALS, GASOLINE AND OTHER FLAMMABLES, VAPORS AND LIQUIDS.

DO NOT OBSTRUCT THE FLOW OF THE COMBUSTION OR VENTILATING AIR.

⚠ WARNING

ATTIC AND/OR EXHAUST FANS OPERATING ON THE PREMISES WITH A WATER HEATER CAN RESULT IN CARBON MONOXIDE POISONING AND DEATH.

OPERATION OF THESE FANS CAN PRODUCE A NEGATIVE DRAFT IN THE AREA OF THE WATER HEATER PREVENTING THE PRODUCTS OF COMBUSTION FROM EXHAUSTING THROUGH THE CHIMNEY OR VENT PIPE.

The venting of the water heater should be inspected by a qualified service technician at the time of installation and periodically thereafter to ensure a down-draft condition does not exist.

⚠ WARNING

FOR SAFE OPERATION PROVIDE ADEQUATE AIR FOR COMBUSTION AND VENTILATION. AN INSUFFICIENT SUPPLY OF AIR WILL CAUSE RECIRCULATION OF COMBUSTION PRODUCTS RESULTING IN AIR CONTAMINATION THAT MAY BE HAZARDOUS TO LIFE. SUCH A CONDITION OFTEN WILL RESULT IN A YELLOW, LUMINOUS BURNER FLAME, CAUSING CARBONING OR SOOTING OF THE COMBUSTION CHAMBER, BURNERS AND FLUE TUBES AND CREATES A RISK OF ASPHYXIATION.

Where an exhaust fan is supplied in the same room with a heater, sufficient openings for air must be provided in the walls. **UNDERSIZED OPENINGS WILL CAUSE AIR TO BE DRAWN INTO THE ROOM THROUGH THE CHIMNEY, CAUSING POOR COMBUSTION. SOOTING MAY RESULT IN SERIOUS DAMAGE TO THE HEATER AND RISK OF FIRE OR EXPLOSION.**

DO NOT OBSTRUCT THE FLOW OF COMBUSTION AND VENTILATING AIR. ADEQUATE AIR FOR COMBUSTION AND VENTILATION MUST BE PROVIDED FOR SAFE OPERATION.

UNCONFINED SPACE

In buildings of conventional frame, brick, or stone construction, unconfined spaces may provide adequate air for combustion, ventilation and draft hood dilution.

If the unconfined space is within a building of tight construction (buildings using the following construction: weather stripping, heavy insulation, caulking, vapor barrier, etc.), air for combustion, ventilation and draft hood dilution must be obtained from outdoors. The installation instructions for confined spaces in tightly constructed buildings must be followed to ensure adequate air supply.

CONFINED SPACE

When drawing combustion and dilution air from inside a conventionally constructed building to a confined space, such a space shall be provided with two permanent openings, ONE IN OR WITHIN 12 INCHES (30.5cm) OF THE ENCLOSURE TOP AND ONE IN OR WITHIN 12 INCHES (30.5cm) OF THE ENCLOSURE BOTTOM. Each opening shall have a free area of at least one square inch per 1000 Btuh (2,225mm²/Kw) of the total input of all appliances in the enclosure, but not less than 100 square inches (645 square cm).

If the confined space is within a building of tight construction, air for combustion, ventilation, and draft hood dilution must be obtained from outdoors. When directly communicating with the outdoors or communicating with the outdoors through vertical ducts, two permanent openings, located in the above manner, shall be provided. Each opening shall have a free area of not less than one square inch per 4000 Btuh (8,900mm²/Kw) of the total input of all appliances in the enclosure. If horizontal ducts are used, each opening shall have a free area of not less than one square inch per 2000 Btuh (4,450mm²/Kw) of the total input of all appliances in the enclosure. For Canadian installations consult CAN/CSA-B149.1.

VENTING

⚠ WARNING

THE INSTRUCTIONS IN THIS SECTION ON VENTING MUST BE FOLLOWED TO AVOID CHOKED COMBUSTION OR RECIRCULATION OF FLUE GASES. SUCH CONDITIONS CAUSE SOOTING OR RISKS OF FIRE AND ASPHYXIATION.

This water heater must be protected from freezing downdrafts.

Remove all soot or other obstructions from the chimney that will retard a free draft.

Type B venting is recommended with these water heaters.

This water heater must be vented in compliance with all local codes, the current edition of the National Fuel Gas Code, ANSI Z223.1/NFPA 54, and with the Category I Venting Tables.

In Canada, venting shall conform to the requirements of the current edition of the CAN/CSA B149.1-00 installation code.

If any part of the vent system are exposed to ambient temperatures below 35 degrees F (2 degrees C) it must be insulated to prevent condensation.

- Do not connect the heater to a common vent or chimney with solid fuel burning equipment. This practice is prohibited by many local building codes as is the practice of venting gas fired equipment to the duct work of ventilation systems.
- Where a separate vent connection is not available and the vent pipe from the heater must be connected to a common vent with an oil burning furnace, the vent pipe should enter the smaller common vent or chimney at a point above the large vent pipe.

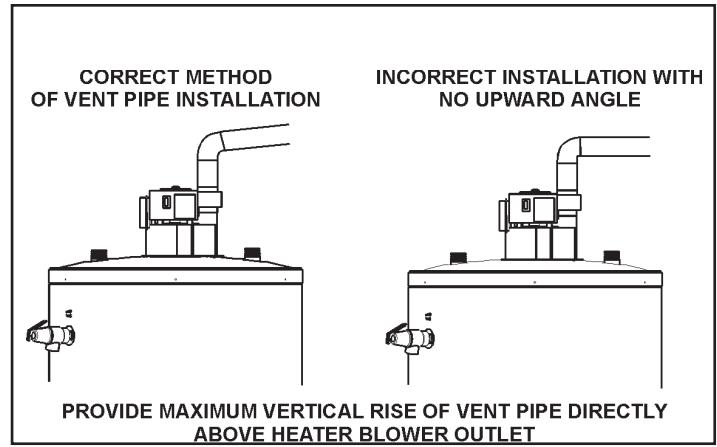

FIGURE 2.

VENT CONNECTION

Vent connections must be made to an adequate stack or chimney. Size and install proper size vent pipe. Do not reduce pipe size to less than that of the blower outlet.

Horizontal runs of vent pipe must have a minimum upward slope toward the chimney of 1/4 inch per foot (2cm per meter). Dampers or other obstructions must not be installed in between the heater and the blower. Be sure that the vent pipe does not extend beyond the inside wall of the chimney.

Where a continuous or intermittent back draft is found to exist, the cause must be determined and corrected. A special vent cap may be required. If the back draft cannot be corrected by the normal methods or if a suitable draft cannot be obtained, a blower type flue gas exhauster must be employed to assure proper venting and correct combustion.

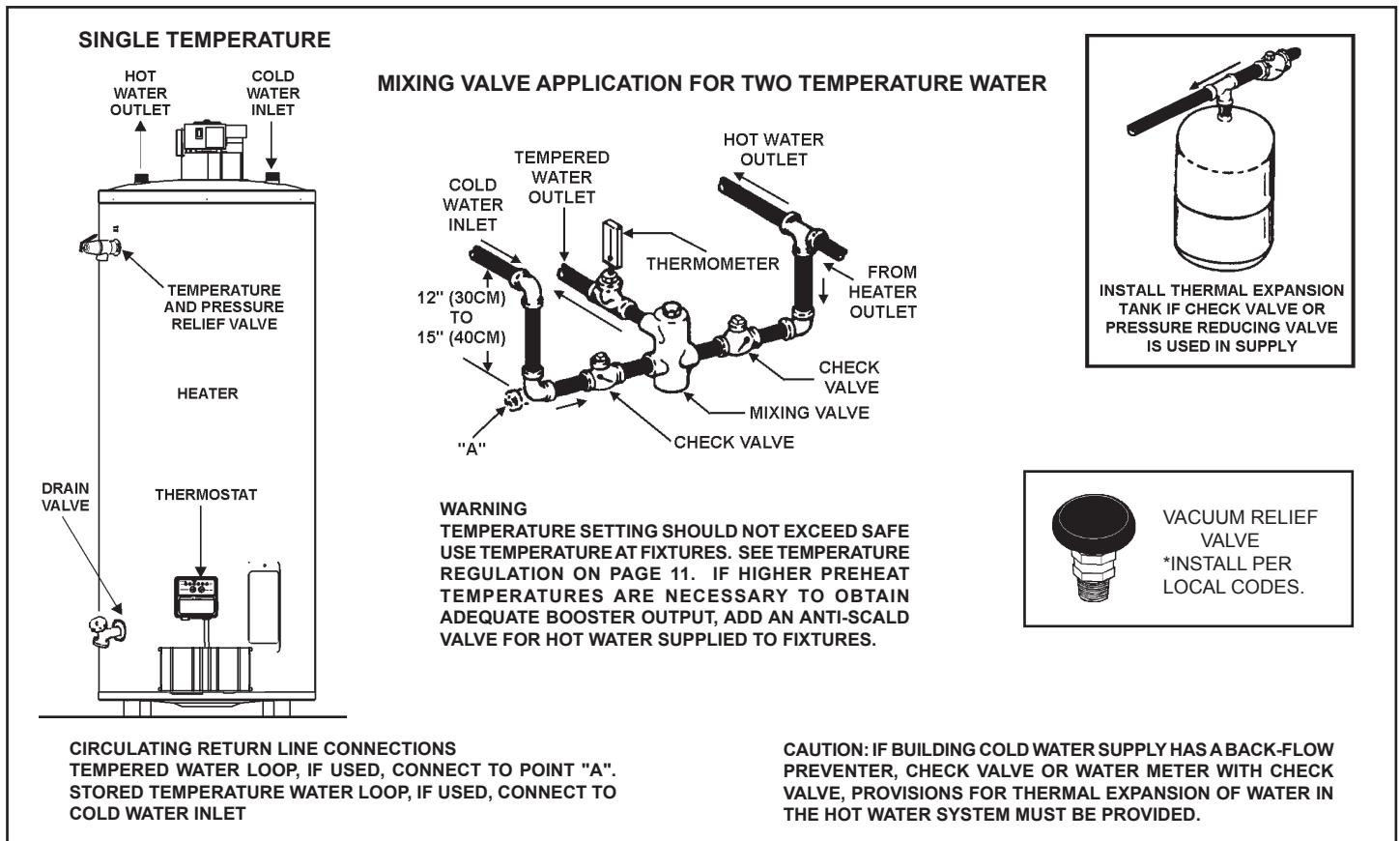

FIGURE 3.

THERMOMETERS (Not Supplied)

Thermometers should be obtained and field installed as shown in Figure 3.

Thermometers are installed in the system as a means of detecting the temperature of the outlet water supply.

COMBINATION WATER (POTABLE) HEATING AND SPACE HEATING

1. All piping components connected to this unit for space heating applications shall be suitable for use with potable water.
2. Toxic chemicals, such as those used for boiler treatment, shall NEVER be introduced into this system.
3. This unit may NEVER be connected to any existing heating system or component(s) previously used with a non-potable water heating appliance.
4. When the system requires water for space heating at temperatures higher than required for domestic water purposes, a tempering valve must be installed. Please refer to installation diagram on page 6 of this manual for suggested piping arrangements.
5. These water heaters cannot be used in space heating applications only.

CAUTION

A closed system will exist if a check valve (without bypass), pressure reducing valve (without bypass), or a water meter (without bypass) is installed in the cold water line between the water heater and street main (or well).

Excessive pressure may develop in such closed systems, causing premature tank failure or intermittent relief valve operation. This is not a warranty failure. An expansion tank or a similar device may be required in the inlet supply line between the appliance and the meter or valve to compensate for the thermal expansion of the water.

SYSTEM CONNECTIONS

The system installation must conform to these instructions and to the local code authority having jurisdiction. Good practice requires that all heavy piping be supported.

RELIEF VALVE

This water heater is equipped with a combination temperature-pressure relief valve that complies with the standard for relief valves for hot water supply systems Z21.22-CSA 4.4. **FOR SAFE OPERATION OF THE WATER HEATER, THE RELIEF VALVE(S) MUST NOT BE REMOVED OR PLUGGED.**

ASME ratings cover pressure relief capacities. ANSI ratings cover release rate with temperature actuation.

In addition to the appliance relief valve, each remote storage tank which may be used in conjunction with this appliance shall also be installed with a properly sized, rated and approved combination temperature (ANSI) and pressure (ASME) relief valve(s). This valve shall comply with the standard for relief valves for hot water supply systems Z21.22-CSA 4.4.

WARNING

THE PURPOSE OF RELIEF VALVE IS TO AVOID EXCESSIVE PRESSURE OR TEMPERATURE INTO THE STEAM RANGE, WHICH MAY CAUSE SCALDING AT FIXTURES, TANK EXPLOSION, SYSTEM OR HEATER DAMAGE. NO VALVE IS TO BE PLACED BETWEEN THE RELIEF VALVE AND TANK.

Your local code authority may have other specific relief valve requirements.

A DRAIN LINE MUST BE CONNECTED TO THE RELIEF VALVE TO DIRECT DISCHARGE TO A SAFE LOCATION TO AVOID SCALDING OR WATER DAMAGE. THIS LINE MUST NOT BE REDUCED FROM THE SIZE OF THE VALVE OUTLET AND MUST NOT CONTAIN VALVES, RESTRICTIONS NOR SHOULD IT BE LOCATED IN FREEZING AREAS. DO NOT THREAD OR CAP THE END OF THIS LINE. RESTRICTED OR BLOCKED DISCHARGE WILL DEFEAT THE PURPOSE OF THE VALVE AND IS UNSAFE. DISCHARGE LINE SHALL BE INSTALLED TO ALLOW COMPLETE DRAINAGE OF BOTH THE VALVE AND LINE.

See SERVICE INFORMATION section for procedure and precautions.

The type, size and location of the relief valves must be in accordance with local codes. The location of the relief valve is shown in Figure 1. The heater has a factory installed high temperature limit switch.

GAS PIPING

Contact your local gas service company to ensure that adequate gas service is available and to review applicable installation codes for your area.

Size the main gas line in accordance with Table 4. The figures shown are for straight lengths of pipe at 0.5 in. W.C. pressure drop, which is considered normal for low pressure systems. Note: Fittings such as elbows, tees and line regulators will add to the pipe pressure drop. Also refer to the current edition of the National Fuel Gas Code. For Canadian installations consult Canadian Installation Code CAN/CSA-B149.1.

WARNING

The minimum gas supply pressure for input adjustment is 6.0" kPa W.C. for natural gas (11.0" kPa W.C. for propane).

THE HEATER IS NOT INTENDED FOR OPERATION AT HIGHER THAN 14" kPa WATER COLUMN SUPPLY PRESSURE. EXPOSURE TO HIGHER GAS SUPPLY PRESSURE MAY CAUSE DAMAGE TO THE CONTROL WHICH COULD RESULT IN FIRE OR EXPLOSION. If overpressure has occurred such as through improper testing of gas lines or emergency malfunction of the supply system, the control must be checked for safe operation. Make sure that the outside vents on the supply regulators and the safety vent valves are protected against blockage. These are parts of the gas supply system not the heater. Vent blockage may occur during ice storms.

IT IS IMPORTANT TO GUARD AGAINST GAS VALVE FOULING FROM CONTAMINANTS IN THE GAS WAYS. SUCH FOULING MAY CAUSE IMPROPER OPERATION, FIRE OR EXPLOSION.

IF COPPER SUPPLY LINES ARE USED THEY MUST BE INTERNALLY TINNED AND CERTIFIED FOR GAS SERVICE. BEFORE ATTACHING THE GAS LINE, BE SURE THAT ALL GAS PIPE IS CLEAN ON THE INSIDE.

TO TRAP ANY DIRT OR FOREIGN MATERIAL IN THE GAS SUPPLY LINE, A DIRT LEG (SOMETIMES CALLED SEDIMENT TRAP OR DRIP LEG) MUST BE INCORPORATED IN THE PIPING (SEE FIG. 5). THE DIRT LEG MUST BE READILY ACCESSIBLE AND NOT SUBJECT TO FREEZING CONDITIONS. INSTALL IN ACCORDANCE WITH RECOMMENDATIONS OF SERVING GAS SUPPLIERS. REFER TO THE CURRENT EDITION OF THE NATIONAL FUEL GAS CODE. For Canadian installations consult Canadian Installation Code CAN/CSA-B149.1.

To prevent damage, care must be taken not to apply too much torque when attaching gas supply pipe to gas valve inlet.

Apply joint compounds (pipe dope) sparingly and only to the male threads of pipe joints. Do not apply compounds to the first two threads. Use compounds resistant to the action of liquefied petroleum gases.

HEATER WIRING

All electrical work must be installed in the United States in accordance with the current edition of the National Electrical Code ANSI/NFPA No. 70, in Canada, with the current edition of Canadian Electrical Code CSA C22.1, must conform to all local code authority having jurisdiction. AN ELECTRICAL GROUND IS REQUIRED TO REDUCE RISK OF ELECTRICAL SHOCK OR POSSIBLE ELECTROCUTION.

If any of the original wire as supplied with the appliance must be replaced, use only type 105°C thermoplastic or equivalent, 250°C type F must be used for the flame sensor leads and the spark ignition cable must be high voltage 250°C.



LABEL ALL WIRES PRIOR TO DISCONNECTION WHEN SERVICING CONTROLS. WIRING ERRORS CAN CAUSE IMPROPER AND DANGEROUS OPERATION. VERIFY PROPER OPERATION AFTER SERVICING.

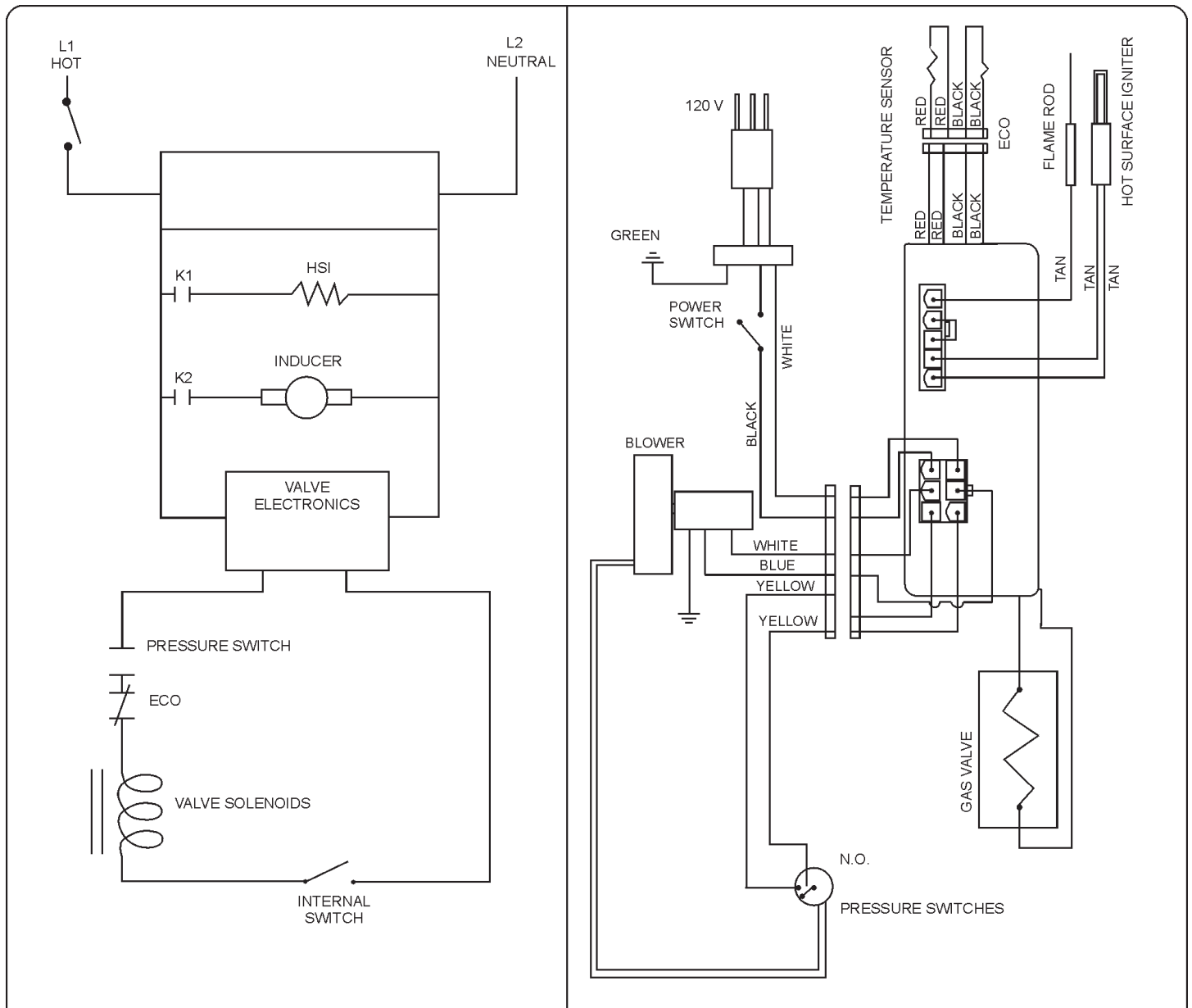

WARNING

DISCONNECT FROM ELECTRICAL SUPPLY BEFORE SERVICING UNIT. REPLACE ALL DOORS AND PANELS BEFORE OPERATING HEATER.

IF ANY OF THE ORIGINAL WIRES SUPPLIED WITH THE APPLIANCE MUST BE REPLACED, IT MUST BE REPLACED WITH APPLIANCE WIRE MATERIAL WITH MINIMUM TEMPERATURE RATING OF 221°F(105°C) AND A MINIMUM SIZE OF NO. 18 AWG.

FIGURE 4. WIRING DIAGRAM AND SCHEMATIC

**TABLE 4. GAS SUPPLY LINE SIZES (IN INCHES)*
MAXIMUM CAPACITY OF PIPE IN
CUBIC FEET PER HOUR**

LENGTH IN FEET	NORMAL IRON PIPE SIZES (INCHES) INPUT IN THOUSANDS BTU/HR								
	1/2"	3/4"	1"	1 1/4"	1 1/2"	2"	2 1/2"	3"	4"
10	175	360	680	1400	2100	3960	6300	11000	230000
20	120	250	485	950	1460	2750	4360	7700	15800
30	97	200	375	770	1180	2200	3520	6250	12800
40	82	170	320	660	990	1900	3000	5300	10900
50	73	151	285	580	900	1680	2650	4750	9700
60	66	138	260	530	810	1520	2400	4300	8800
70	61	125	240	490	750	1400	2250	3900	8100
80	57	118	220	460	690	1300	2050	3700	7500
90	53	110	205	430	650	1220	1950	3450	7200
100	50	103	195	400	620	1150	1850	3250	6700
125	44	93	175	360	550	1020	1650	2950	6000
150	40	84	160	325	500	950	1500	2650	5500
175	37	77	145	300	460	850	1370	2450	5000
200	35	72	135	280	430	800	1280	2280	4600
LENGTH IN METERS	NORMAL IRON PIPE SIZES (INCHES) INPUT IN KW								
	1/2"	3/4"	1"	1 1/4"	1 1/2"	2"	2 1/2"	3"	4"
3.0	51	105	199	410	615	1160	1845	3221	6735
6.1	35	73	142	278	428	805	1277	2255	4626
9.1	28	59	110	225	346	644	1031	1830	3748
12.2	24	50	94	193	290	556	878	1552	3192
15.2	21	44	83	170	264	492	776	1391	2840
18.3	19	40	76	155	237	445	703	1259	2577
21.3	18	37	70	143	220	410	659	1142	2372
24.4	17	35	64	165	202	381	600	1083	2196
27.4	16	32	60	126	190	357	571	1010	2108
30.5	15	30	57	117	182	337	542	952	1962
38.1	13	27	51	105	161	299	483	864	1757
45.7	12	25	47	95	146	278	439	776	1610
53.3	11	23	42	88	135	249	401	717	1464
61.0	10	21	40	82	126	234	375	688	1347

BEFORE PLACING THE HEATER IN OPERATION, CHECK FOR GAS LEAKAGE. Use soap and water solution or other material acceptable for the purpose in locating the leaks. **DO NOT USE MATCHES, CANDLES, FLAME OR OTHER SOURCES OF IGNITION FOR THIS PURPOSE.**

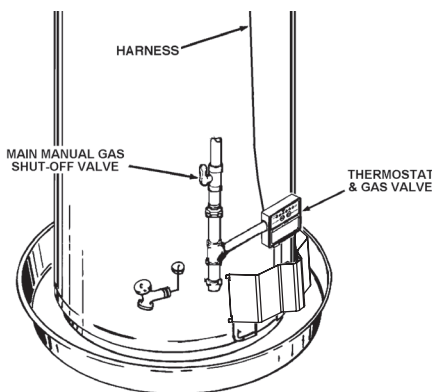

FIGURE 5. GAS PIPING AND SEDIMENT TRAP INSTALLATION

DISCONNECT THE HEATER AND ITS MANUAL GAS SHUTOFF VALVE FROM THE GAS SUPPLY PIPING SYSTEM DURING ANY SUPPLY PRESSURE TESTING EXCEEDING 1/2 PSIG (3.45 kPa). GAS SUPPLY LINE MUST BE CAPPED WHEN DISCONNECTED FROM THE HEATER FOR TEST PRESSURES OF 1/2 PSIG (3.45 kPa) OR LESS. THE APPLIANCE NEED NOT BE DISCONNECTED, BUT MUST BE ISOLATED FROM THE SUPPLY PRESSURE TEST BY CLOSING THE MANUAL GAS SHUTOFF VALVE.

PURGING

Gas line purging is required with new piping or systems in which air has entered.

⚠ CAUTION

PURGING SHOULD BE PERFORMED BY PERSONS EXPERIENCED IN THIS TYPE GAS SERVICE. TO AVOID RISK OF FIRE OR EXPLOSION, PURGE DISCHARGE MUST NOT ENTER CONFINED AREAS OR SPACES WHERE IGNITION CAN OCCUR. THE AREA MUST BE WELL VENTILATED AND ALL SOURCES OF IGNITION MUST BE INACTIVATED OR REMOVED.

GAS METER SIZE — NATURAL GASES ONLY

Be sure the gas meter has sufficient capacity to supply the full rated gas input of the water heater as well as the requirements of all other gas fired equipment supplied by the meter. If gas meter is too small, ask the gas company to install a larger meter having adequate capacity.

GAS PRESSURE REGULATOR

The gas pressure regulator is built into the gas valve and is equipped to operate on the gas specified on model and rating plate. The regulator is factory adjusted to deliver gas to burner at correct water column pressure allowing for a nominal pressure drop through the controls.

The minimum gas supply pressure for input adjustment must not be less than 6" w.c. (1.49 kPa) for natural gas and 11" w.c. (2.73 kPa).

Do not subject the combination gas valve to inlet gas pressures of more than 14.0" w.c. (3.48 kPa) - natural gas. A service regulator is necessary if higher gas pressures are encountered.

Gas pressure specified in Table 5, refer to flow pressure taken at pressure tap of automatic gas valve while heater is operating.

TABLE 5.

Type of Gas	Input	Manifold Pressure
Natural	75,100 Btu/hr 22 KW/hr	4.0 in. W.C. 1.12 kPa

OPERATION

It is recommended that a qualified person perform the initial firing of the heater. At this time the user should not hesitate to ask the individual any questions which he may have in regard to the operation and maintenance of the unit.

TO OPERATE THE HEATER

1. Close the heater drain valve (Figure 1) by turning handle clockwise.
2. Open a nearby hot water faucet to permit the air in the system to escape.
3. Fully open the cold water inlet pipe valve (Figure 1) allowing the heater and piping to be filled.
4. Close the hot water faucet as water starts to flow.
5. The heater is ready to be operated.

⚠ WARNING

DO NOT ATTEMPT TO OPERATE WATER HEATER WITH COLD WATER INLET VALVE CLOSED.

NEVER OPERATE THE HEATER WITHOUT FIRST BEING CERTAIN IT IS FILLED WITH WATER AND A TEMPERATURE AND PRESSURE RELIEF VALVE IS INSTALLED IN THE RELIEF VALVE OPENING OF THE HEATER.

FOR YOUR SAFETY READ BEFORE OPERATING



WARNING: If you do not follow these instructions exactly, a fire or explosion may result causing property damage, personal injury or loss of life.









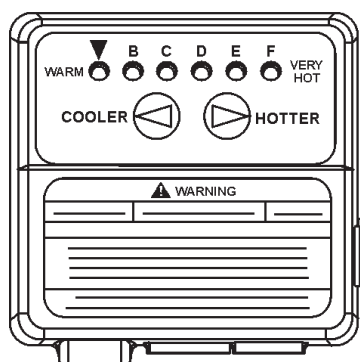



BEFORE OPERATING: ENTIRE SYSTEM MUST BE FILLED WITH WATER AND AIR PURGED FROM ALL LINES.

- A. This appliance does not have a pilot. It is equipped with an ignition device which automatically lights the burner. Do not try to light the burner by hand.
- B. **BEFORE OPERATING** smell all around the appliance area for gas. Be sure to smell next to the floor because some gas is heavier than air and will settle on the floor.
- WHAT TO DO IF YOU SMELL GAS:**
- Do not try to light any appliance.
 - Do not touch any electric switch; do not use any phone in your building.
 - Immediately call your gas supplier from a neighbor's phone. Follow the gas supplier's instructions.
- C. Use only your hand to push in the control buttons. Never use tools. If the control buttons will not push in, don't try to repair them, call a qualified service technician. Force or attempted repair may result in a fire or explosion.
- D. Do not use this appliance if any part has been under water. Immediately call a qualified service technician to inspect the appliance and to replace any part of the control system and any gas control which has been under water.

OPERATING INSTRUCTIONS



1.  STOP! Read the safety information above on this label.
2. Set the thermostat to the lowest setting by first pressing the COOLER  and HOTTER  buttons together and holding for 1 second. Then press the COOLER  button until the WARM indicator light appears.
3. Turn the "ON/OFF" switch on the blower control to the "OFF" position.
4. This appliance is equipped with a device which automatically lights the burner.
DO NOT TRY TO LIGHT THE BURNER BY HAND.
5. Wait five (5) minutes  to clear out any gas. If you then smell gas, STOP! Follow "B" in the safety information  above on this label. If you don't smell gas, go to next step.
6. Turn on all electrical power to the appliance.
7. Set thermostat to desired setting by first pressing the COOLER  and HOTTER  buttons together and holding for 1 second. Then press the HOTTER  button.
8. If the appliance will not operate, follow the instructions "TO TURN OFF GAS TO APPLIANCE" and call your technician or gas supplier.
9. WATER TEMPERATURE ADJUSTMENT
 is approximately 120°F (49°C).



CAUTION: Hotter water increases the risk of scald injury. Consult the instruction manual before changing temperatures.



WARNING: TURN OFF ALL ELECTRIC POWER BEFORE SERVICING

TO TURN OFF GAS TO APPLIANCE

- A. Set thermostat to the lowest setting.
- B. Turn off all the electric power to the appliance if service is to be performed.

TEMPERATURE REGULATION



⚠ DANGER

THIS WATER HEATER IS EQUIPPED WITH AN ADJUSTABLE THERMOSTAT TO CONTROL WATER TEMPERATURE. HOT WATER TEMPERATURES REQUIRED FOR AUTOMATIC DISHWASHING AND LAUNDRY USE CAN CAUSE PAINFUL SCALDING WITH POSSIBLE SERIOUS AND PERMANENT INJURY. THE TEMPERATURE AT WHICH INJURY OCCURS VARIES WITH THE PERSON'S AGE AND THE TIME OF THE EXPOSURE. THE SLOWER RESPONSE TIME OF CHILDREN, AGED OR DISABLED PERSONS INCREASES THE HAZARDS TO THEM. NEVER ALLOW SMALL CHILDREN TO USE A HOT WATER TAP, OR TO DRAW THEIR OWN BATH WATER. NEVER LEAVE A CHILD OR DISABLED PERSON UNATTENDED IN A BATHTUB OR SHOWER.

THE WATER HEATER SHOULD BE LOCATED IN AN AREA WHERE THE GENERAL PUBLIC DOES NOT HAVE ACCESS. IF A SUITABLE AREA IS NOT AVAILABLE, A COVER SHOULD BE INSTALLED OVER THE THERMOSTAT TO PREVENT TAMPERING. Suitable covers are available from the manufacturer, authorized service agencies or distributors. When ordering parts be sure to have the complete water heater Model Number, Serial Number and Series Number available. This information can be found on the rating label affixed to the water heater.

It is recommended that lower water temperatures be used to avoid the risk of scalding. It is further recommended, in all cases, that the water temperature setting be set for the lowest temperature that satisfies your hot water needs. This will also provide the most energy efficient operation of the water heater. The water temperature adjustment was factory set at the lowest temperature. Pressing the "COOLER" button decreases temperature and pressing the "HOTTER" button increases the temperature.

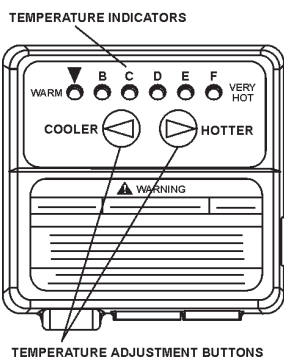

Temperature Setting	Display ▼ B C D E F	Time to Produce 2nd & 3rd Degree Burns on Adult Skin
F = approx. 180°F (82°C)	○○○○○●	Nearly Instantaneous
E = approx. 170°F (77°C)	○○○○●○	Nearly Instantaneous
D = approx. 160°F (71°C)	○○○●○○	About 1/2 Second
C = approx. 150°F (65°C)	○○●○○○	About 1 1/2 Seconds
B = approx. 140°F (60°C)	○●○○○○	Less than 5 Seconds
B = approx. 130°F (54°C)	●●○○○○	More than 30 Seconds
▼ = approx. 120°F (49°C)	●○○○○○	More than 5 Minutes

FIGURE 6.

SETTING THE WATER HEATER TEMPERATURE AT 120°F (49°C) (APPROX. "▼" MARK ON FACE OF THE TEMPERATURE ADJUSTING DIAL) WILL REDUCE THE RISK OF SCALDS. Some States or Provinces require settings at specific lower temperatures.

Figure 6 shows the approximate water temperatures produced at various thermostat settings. Short repeated heating cycles caused by small hot water uses can cause temperatures at the point of use to exceed the thermostat setting by up to 20°F (11°C). If you experience this type of use you should consider using lower temperature settings to reduce scald hazards.

Valves for reducing point of use temperature by mixing cold and hot water are available. Also available are inexpensive devices that attach to faucets to limit hot water temperatures. Contact a licensed plumber or the local plumbing authority.

To avoid any unintentional changes in water temperature settings, the control has a tamper resistant feature for changing the temperature setting. To change the temperature setting follow these instructions:

- "Wake Up" the temperature indicators by holding down both the "COOLER" and "HOTTER" temperature adjustment buttons at the same time for one second (see Figure 6). One or two of the temperature indicators will light up. These indicators will only remain on for 30 seconds if no further buttons are pressed. After 30 seconds the control will go back to "Sleep" mode.
- Release both of the temperature adjustment buttons.
 - To decrease the temperature press and release the "COOLER" button until desired setting is reached.
 - To increase the temperature press and release the "HOTTER" button until the desired setting is reached.

NOTE: Holding down the button will not continue to lower or raise the temperature setting. The button must be pressed and released for each temperature change desired.

SHOULD OVERHEATING OCCUR OR THE GAS SUPPLY FAIL TO SHUT OFF, TURN OFF THE MAIN MANUAL GAS SHUTOFF VALVE TO THE APPLIANCE. SEE FIGURE 1 (G).

CHECKING VENTING

The following steps shall be followed with each appliance connected to the venting system placed in operation, while any other appliances connected to the venting system are not in operation.

- Seal any unused openings in the venting system.
- Inspect the venting system for proper size and horizontal pitch, as required in the National Fuel Gas Code, ANSI Z223.1/NFPA 54 or the CAN/CSA-B149.1 Installation codes and these instructions. Determine that there is no blockage or restriction, leakage, corrosion and other deficiencies which could cause an unsafe condition.
- So far as is practical, close all building doors and windows and all doors between the space in which the water heater(s) connected to the venting system are located and other spaces of the building. Turn on all appliances not connected to the venting system. Turn on all exhaust fans, such as range hoods and bathroom exhausts, so they shall operate at maximum speed. Close fireplace dampers.
- Follow the lighting instruction. Place the water heater being inspected in operation. Adjust thermostat so appliance shall operate continuously.
- Test for vent system leakage after 5 minutes of main burner operation.

- After it has been determined that each appliance connected to the venting system properly vents when tested as outlined above, return doors, windows, exhaust fans, fireplace dampers and any other gas burning appliance to their previous conditions of use.
- If improper venting is observed during any of the above tests, the venting system must be corrected.

⚠ WARNING

FAILURE TO CORRECT BACK DRAFTS MAY CAUSE AIR CONTAMINATION AND UNSAFE CONDITIONS.

HIGH TEMPERATURE LIMIT SWITCH (ECO)

The water heater is equipped with a manual reset type high limit (Energy Cutoff) sensor. The high limit switch interrupts the main burner gas flow should the water temperature reach 195°F (90°C). The high limit switch must be manually reset by turning the power to the water heater off for 5 seconds then back on and cannot be reset until the water temperature drops below 120°F (49°C). It is important that a serviceman be called to determine the reason for limit operation and thus avoid repeated thermostat resetting.

⚠ WARNING

THE ON/OFF SWITCH MUST HAVE BEEN IN THE OFF POSITION FOR AT LEAST 5 MINUTES. This waiting period is an important safety step. Its purpose is to permit gas that may have accumulated in the combustion chamber to clear. **IF YOU DETECT GAS ODOR AT THE END OF THIS PERIOD DO NOT PROCEED WITH LIGHTING. RECOGNIZE THAT GAS ODOR, EVEN IF IT SEEMS WEAK, MAY INDICATE PRESENCE OF ACCUMULATED GAS SOMEPLACE IN THE AREA WITH RISK OF FIRE OR EXPLOSION. SEE THE FRONT PAGE FOR STEPS TO BE TAKEN.**

SHOULD OVERHEATING OCCUR OR THE GAS SUPPLY FAIL TO SHUT OFF, TURN OFF THE MANUAL GAS CONTROL VALVE TO THE APPLIANCE.

SERVICE INFORMATION

The installer may be able to observe and correct certain problems which may arise when the unit is put into operation. HOWEVER, it is recommended that only qualified servicemen, using appropriate test equipment, be allowed to service the heater.

FOR YOUR SAFETY AND SATISFACTORY OPERATION, IT IS RECOMMENDED THAT THIS HEATER BE CHECKED ONCE A YEAR BY A COMPETENT SERVICE PERSON.

USERS OF THIS WATER HEATER SHOULD BE AWARE THAT GAS COMPONENTS WEAR OUT OVER A PERIOD OF TIME. THE GAS CARRYING COMPONENTS OF THIS WATER HEATER SHOULD BE INSPECTED FOR PROPER OPERATION PERIODICALLY BY A QUALIFIED SERVICE TECHNICIAN.

MAIN BURNER AND IGNITER

Check main burner (figure 7) at least every 6 months for proper flame characteristics. The main burner should display the following characteristics:

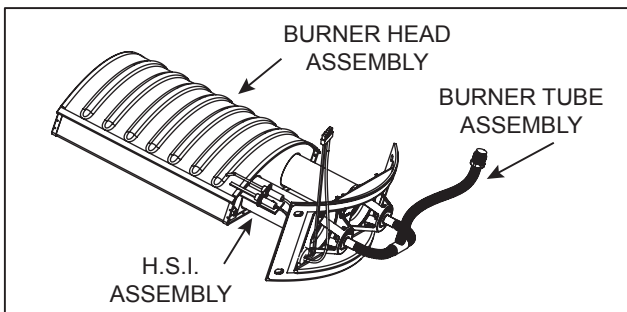

FIGURE 7. MAIN BURNER AND IGNITER ASSEMBLY

- Provide complete combustion of gas.
- Cause rapid ignition and carryover of flame across entire burner.
- Give reasonably quiet operation during ignition, burning and extinction.
- Cause no excessive lifting of flames from burner ports.

If preceding burner characteristics are not evident, check for accumulation of lint or other foreign material that restricts or blocks the air openings to the heater or burner.

⚠ WARNING

SOOT BUILD-UP INDICATES A PROBLEM THAT REQUIRES CORRECTION BEFORE FURTHER USE. CONSULT WITH A QUALIFIED SERVICE TECHNICIAN.

Should the main burner or burner air openings require cleaning, remove the burner and clean with a soft brush. Clean main burner orifice with a suitable soft material.

CHECK FOR GOOD FLOW OF COMBUSTION AND VENTILATING AIR TO THE UNIT. MAINTAIN A CLEAR OPEN AREA AROUND THE HEATER AT ALL TIMES. DO NOT STORE COMBUSTIBLES OR FLAMMABLE LIQUIDS NEAR OR AROUND AN APPLIANCE.

CHECKING GAS INPUT

For appliance installation locations with elevation above 2000 ft.(610m) refer to HIGH ALTITUDE INSTALLATIONS section of this manual for input reduction procedure.

With this heater in operation, determine whether it is receiving the full rated input of gas. This may be done by timing the gas meter and measuring gas pressure with a gauge or manometer. When the heater is operating at full capacity (full gas input) it should consume approximately 1 cubic foot of gas in the time shown in table 6.

**TABLE 6
INPUT CHECK TIME REQUIRED TO CONSUME 1 CU. FT. OF GAS**

Type of Gas	BTU Per Cu. Ft.	Time Required To Consume 1 Cu. Ft. of Gas
Natural	1050	50.3 Seconds

Use this formula to "clock" the meter. Be sure that other gas consuming appliances are not operating during this interval.

$$\frac{3,600}{T} \times H = \text{Btu/h}$$

T = Time in seconds needed to burn one cubic foot of gas.

H = Heating value of gas in Btu's per cubic foot of gas.

Btuh = Actual heater input rate.

Example:

$$T = 47.2 \text{ seconds/ft}^3$$

$$H = 1,050 \text{ Btu/ft}^3 \text{ (natural gas)}$$

$$\text{Btuh} = ?$$

$$\frac{3,600}{50.3} \times 1,050 = 75,100 \text{ Btu/h (22Kw)}$$

Compare the actual input rate to that given on the heater's rating plate. In the example, the full input rate should be 75,000 Btu/h (22 Kw) for natural gas.

VENT SYSTEM

Examine the venting system every 6 months for obstructions and/or deterioration of vent piping.

BLOWER MAINTENANCE

For safety and satisfactory operation it is recommended that the blower be checked once a year by a competent service person.

1. MOTOR - The motor is factory oiled and sealed and requires no further maintenance.
2. WHEEL - Wheel must be clean of soot, ash or any other coating which inhibits either rotation or air flow. Remove all foreign material from vent system.
3. The pressure switch is inside the blower control box and is connected to the blower housing with a tube. This tubing should be soft and pliable and show no sign of deterioration.

RELIEF VALVE

At least once a year the temperature and pressure relief valve should be checked to ensure that it is in operating condition. (During manual operation of this valve, avoid any contact with hot water and take preventive steps for water damage). Lift the lever at the top of the valve several times until the valve seats properly and operates freely.

⚠ WARNING

THE WATER PASSING OUT OF THE VALVE DURING THIS CHECKING OPERATION MAY BE EXTREMELY HOT. AVOID CONTACT AND DISCHARGE SAFELY TO PREVENT WATER DAMAGE.

If the temperature and pressure relief valve on the heater discharges periodically or continuously, a problem exists. This may be due to unusually high water temperatures or pressures in the system, or to a faulty relief valve. Contact your dealer or a qualified service technician to find the cause of the problem and to correct it. This may also be due to thermal expansion in a closed water supply system. Contact the water supplier or local plumbing inspector on how to correct this situation. **DO NOT PLUG THE TEMPERATURE AND PRESSURE RELIEF VALVE.**

⚠ WARNING

SHOULD OVERHEATING OCCUR OR THE GAS SUPPLY FAIL TO SHUT OFF, TURN OFF THE MANUAL GAS CONTROL VALVE TO THE APPLIANCE.

HOT WATER ODOR

On occasion, hot water may develop a strong odor. If this occurs drain the heater completely, flush thoroughly, and refill. If the problem persists, chlorination of the heater and replacement of the factory installed magnesium anode with aluminum anode may correct the condition.

Occasionally water softener companies recommend removal of heater anodes for odor reasons.

⚠ CAUTION

Unauthorized removal of heater anode will void the warranty. Replace the anode as necessary to maintain corrosion protection. For further information contact your dealer.

WINTER PROTECTION

In regions where freezing weather is encountered, all water must be drained from unit and piping when out of service (water shut off). Drain valve must be left open until unit is returned to service.

REPLACEMENT PARTS

Replacement parts may be ordered from the manufacturer, authorized service agencies or distributors. When ordering parts be sure to have the complete water heater Model Number, Serial Number and Series Number available. This information can be found on the rating label affixed to the water heater. Refer to the parts list included with the water heater from the factory for more information or call the parts department or technical support phone number listed on the back cover of this manual for further assistance.

PREVENTIVE MAINTENANCE

RECOMMENDED PROCEDURE FOR PERIODIC REMOVAL OF LIME DEPOSITS FROM TANK TYPE COMMERCIAL WATER HEATERS

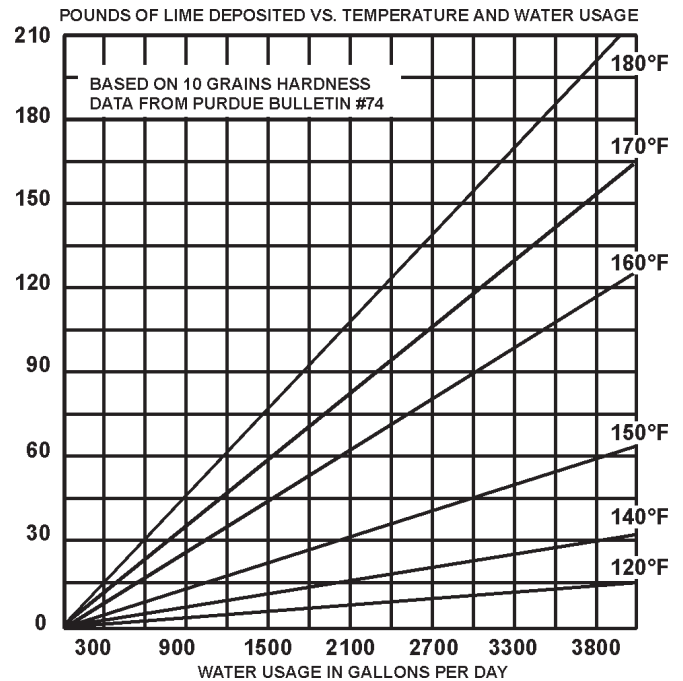

FIGURE 8.

The amount of calcium carbonate (lime) released from water is in direct proportion to water temperature and usage, see chart. The higher the water temperature or water usage, the more lime deposits are dropped out of the water. This is the lime scale which forms in pipes, heaters and on cooking utensils.

Lime accumulation not only reduces the life of the equipment but also reduces efficiency of the heater and increases fuel consumption.

The usage of water softening equipment greatly reduces the hardness of the water. However, this equipment does not always remove all of the hardness (lime). For this reason it is recommended that a regular schedule for deliming be maintained.

The time between cleaning will vary from weeks to months depending upon water conditions and usage.

UN•LIME® and the booklet may be obtained through your dealer or distributor.

DELIMING SOLVENTS

UN•LIME is recommended for deliming. UN•LIME is a patented food grade acid which is safe to handle and does not create the harmful fumes which are associated with other products.

UN•LIME may be obtained from your dealer, distributor or water heater manufacturer. Order Part Number 9005416105, 1 gallon, packed 4 gallons per case or Part Number 9005417105, 5 gallon container.

NOTE: Un•Lime is not available for use in Canada. Hydrochloric base acids are not recommended for use on glass-lined tanks.

⚠ CAUTION

Observe handling instructions on label of product being used.

TANK CLEANOUT PROCEDURE

The following practices will ensure longer life and enable the unit to operate at its designed efficiency:

1. Once a month the heater should be flushed. Open the drain valve and allow two gallons of water to drain from the heater. Inlet water valve should remain open to maintain pressure in tank.
2. A cleanout opening is provided for periodic cleaning of the tank. Gas must be shut off and heater drained before opening cleanout.

To clean heater through cleanout opening, proceed as follows:

1. Drain heater.
2. Remove outer cover plate from lower side of heater jacket.
3. Remove six (6) hex head screws securing tank cleanout plate and remove plate.
4. Remove lime, scale, or sediment using care not to damage the glass lining.
5. Inspect cleanout plate gasket, if new gasket is required.
6. Install cleanout plate. Be sure to draw plate up tight by tightening screws securely.
7. Replace outer jacket cover plate.

In some water areas the sediment might not be removed by this method and may result in the water heater making rumbling or boiling noises. To dissolve and remove these more stubborn mineral deposits, UN•LIME Professional Delimer should be used.

2. With the Flo-Jug upright:

- Take off cap, remove cover under opening and install 3/4" x 4" pipe nipple.
- Drill or punch a 3/16" vent hole in handle. A stainless steel screw is included with the Flo-Jug kit. This screw is to be installed in the vent hole when Flo-Jug is not in use.
- Remove drain valve from heater and insert a 3/4" x 4" nipple.
- Connect and clamp 1" I.D. x 3" hose to Flo-Jug and heater nipple.

3. Lift the Flo-Jug to the POUR POSITION and permit the UN•LIME to flow into the heater as rapidly as possible.

- Be sure to keep the vent just above the liquid level.

4. Place the Flo-Jug in the DELIME POSITION.

- It may be necessary to place the empty jug on its carton to trap the solution in the heater.
- Allow the UN•LIME to attack the water scale for 5 minutes.

5. Lower the Flo-Jug to the DRAIN POSITION and allow the UN•LIME to flow out of the heater as rapidly as possible.

- Observe the vent holes and elevate the jug slightly if there is a possibility of spillage.
- Deliming activity is indicated by foaming on the surface of the solution.

6. Continue the deliming process:

- Raise jug to POUR POSITION. Allow solution to flow into heater.
- Place jug in DELIME POSITION for 5 minutes. Solution is at work in heater.
- Lower jug to DRAIN POSITION and allow solution to flow out. Observe foaming.

7. After one hour, or earlier if the deliming activity (foaming) stops, inspect the tank interior.

- Drain the UN•LIME back into jug, DRAIN POSITION, and then stand jug in DELIME POSITION.
- Remove the clamp, hose and the pipe nipple from heater drain opening.
- Observe interior through opening - a small flashlight may be used effectively.
- If the interior still shows water scale, the deliming process should be continued.

- To check UN•LIME for continued use or reuse, place some lime scale or white chalk into a glass with a small amount of solution. If the material is vigorously dissolved by the solution, the UN•LIME can be reused. If not, the UN•LIME has been weakened and should be replaced.

8. When deliming has been completed, the heater should be flushed for 3 to 5 minutes with fresh water.

- Remove the deliming equipment, install the drain valve, open the

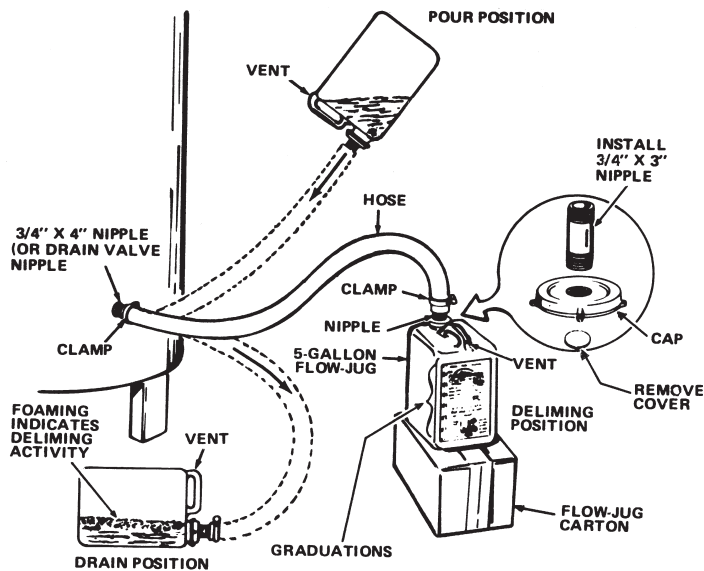

FIGURE 9

FLO-JUG METHOD OF DELIMING

The Flo-Jug is the standard 5 gallon container for UN•LIME -or- it is available as a deliming kit with hose and fittings. Contact your dealer or distributor.

Figure 9 illustrates most of the following steps.

1. The heater should be prepared for deliming as described in the "Why? When and How" booklet. The relief valve may also be delimed at this time.

cold water inlet line and allow water to flow through heater and out drain valve. Don't forget to plug vent and cap opening in Flo-Jug.

9. When flushing is completed:

- Fill heater being certain to expel air from tank through a nearby hot water faucet or, if removed, the relief valve opening.
- The heater relief valve can be washed in UN•LIME if it is limed.
- Replace relief valve if removed for deliming.
- Restore gas, oil or electrical supply to heater.
- Check for water leakage.

10. Flo-Jug cleanup:

- Allow scale to separate from UN•LIME and settle on bottom of Flo-Jug.
- Pour off UN•LIME into plastic container and check for reuse.
- Rinse sediment from Flo-Jug.

CHECKLIST

Before contacting your dealer, check the water heater to see if the apparent malfunction is caused by some external fault. Consulting this checklist may eliminate the need for a repair call and restore hot water service.

NOT ENOUGH OR NO HOT WATER

1. Look for leaking or open hot water faucets. Check for excessive usage.
2. Your gas company can check the gas input to the heater to see that it is correct. An underfired heater will not produce hot water at its normal recovery rate.
3. If the heater was installed when incoming water temperatures were warm, colder incoming temperatures will create the effect of less hot water.
4. The thermostat water temperature adjusting dial may be set too low.
5. If you cannot determine the cause of the problems, contact your dealer.

WATER TEMPERATURE IS TOO HOT

1. The thermostat water temperature adjusting dial may be set too high.
2. If lowering control setting does not reduce the water temperature contact your dealer.

GAS SMELL AT THE HEATER

1. Close the main shutoff valve in the gas supply pipe near the heater, see Figure 5 on page 9. The thermostat includes a gas control (top knob) which can also be closed.
2. Call your gas company.

WATER LEAKAGE IS SUSPECTED

1. Check to see if the heater drain valve is tightly closed.
2. The apparent leakage might be condensation. In warm or humid locations, condensation can accumulate and run from within the heater or its piping.

- When a water heater is first installed and filled, the bottom of the tank might condense water. The water accumulation, if excessive, can drip into the floor shield. Also, during normal operation there may be occasions when large quantities of water are drawn, chilling the tank bottom. This too can result in condensation.
- Condensation, appearing in the vent pipe (water dripping from draft diverter) during heater operation is evidence of poor vent action. Possible causes are too long a vent pipe or improper chimney operation.

3. If the leakage is from the temperature and pressure relief valve or its discharge pipe, it may represent a normal condition. However, see RELIEF VALVE section on page 7. DO NOT PLUG THE TEMPERATURE AND PRESSURE RELIEF VALVE. Also, the leakage could be due to unusually high water pressures or temperatures in the system, or to a faulty relief valve. Your dealer or a qualified service technician should be called to determine the cause of the problem and to correct it.

4. If you cannot identify or correct the source of water leakage:

- Close the main shutoff valve in the gas supply pipe at the heater. See Figure 5, page 9.
- Close the valve which feeds water to the cold water inlet at the top of the heater.
- Contact your dealer.

WATER HEATER MAKES SOUNDS

1. Occasional excessive condensation, as explained under LEAKAGE, can cause a sizzling sound as the moisture is vaporized by the gas flame. This is a normal sound and may be disregarded.
2. Sediment and water scale accumulations may cause rumbling noises. See MAINTENANCE or contact your dealer for details of flushing the heater.
3. If you cannot identify or remedy the condition, contact your dealer.

CONDENSATION

Water vapor can condense on the cooler surfaces of the tank forming droplets, these drip into the fire or run out on the floor. This is common at the time of startup after installation, during periods of time when incoming water is very cold, or the heater may be undersized for the requirements.

Droplets from the bottom of the flue may be due to corrosive combustion products or improper vent. Check with your dealer for more information.

ANODE

The anode rod is used to protect the tank from corrosion. Most hot water tanks are equipped with an anode rod. The submerged rod sacrifices itself to protect the tank. Instead of corroding the tank, water ions attack and eat away the anode rod. This does not affect the water's taste or color. The rod must be maintained to keep the tank in operating condition.

Anode deterioration depends on water conductivity, not necessarily water condition. A corroded or pitted anode rod indicates high water conductivity and should be checked and/or replaced more often than an anode rod that appears to be intact. Replacement of a depleted anode rod can extend the life of your water heater. Inspection should be conducted by a qualified technician, and at a minimum should be checked annually after the warranty period.

A hydrogen sulfide (rotten egg) odor may result if water contains high sulfate and/or minerals. Chlorinating the water supply should minimize the problem. (See EXTENDED NON-USE PERIODS).

NOTE: Anode must remain installed (except for inspection) to avoid shortening tank life. See LIMITED WARRANTY. Replace as necessary.

SERVICE AND REPAIR

The water heater requires no special care other than the normal maintenance as noted above. If you are having a problem with your water heater, before calling for service please refer to the following TROUBLESHOOTING sections. If service becomes necessary, contact your dealer, installer or an authorized service agent. Do not attempt to repair the water heater yourself. Any work performed by unauthorized personnel may void the warranty.

Please be sure to provide the following information when writing or e-mailing:

- Model Number
- Serial Number
- Date of Original Purchase
- Date Problem Originated
- Explanation of Problem

Also, please be sure to include a daytime telephone number.

TROUBLESHOOTING

Water heaters may exhibit problems that are unrelated to a malfunction of the water heater itself. The following information and tables may serve to answer your question about a problem that you are having without having to call a service agent.

For your safety, water heater service should be performed only by a qualified service technician. Read the GENERAL SAFETY INFORMATION section first.

WATER HEATING CYCLE

(GAS AND ELECTRIC POWER ARE ON, "OFF/ON" SWITCH IS ON)

- 1) CALLS FOR HEAT
 - A) THERMOSTAT SENSES NEED FOR HEATING WATER
 - B) CONTACTS CLOSE IN THERMOSTAT, POWER (115 VAC) FLOWS TO BLOWER MOTOR
- 2) BLOWER MOTOR ROTATES BLOWER WHEEL
 - A) BLOWER WHEEL SPEED INCREASES
 - B) WHEEL SPEED INCREASES, AIR PRESSURE SWITCH CONTACTS CLOSE
- 3) 120 VAC FLOWS TO HOT SURFACE IGNITER

NOTE: THE CONTROL MODULE ON THIS UNIT WILL TRY A MAXIMUM OF THREE TIMES TO LIGHT THE UNIT. CYCLE CAN BE RESTARTED AT ANY TIME BY TURNING OFF SWITCH AND THEN TURNING BACK ON. IF UNIT HAS GONE THROUGH THREE CYCLES AND DID NOT LIGHT, THEN REPAIRMAN SHOULD BE CALLED TO CHECK OPERATION OF HEATER.

- 4) MAIN BURNER IGNITES
 - A) GAS FLOWS TO MAIN BURNER PORTS AND IS IGNITED
- 5) GAS VALVE SENSES BURNER FLAME
- 6) BURNER HEATS WATER
 - A) BURNER HEATS WATER TO THERMOSTAT SETTING
 - B) CONTACTS IN THERMOSTAT OPEN,
 - C) CYCLE IS COMPLETED

TROUBLESHOOTING

For your safety, water heater service should be performed only by a qualified service technician.
Read the GENERAL SAFETY INFORMATION section first.

PROBLEM	POSSIBLE MALFUNCTION	SERVICE TO BE PERFORMED
NOT ENOUGH OR NO HOT WATER	1) Blower will not run.	
	A) "ON/OFF" control switch turned off.	Turn switch to the on position.
	B) Blower unplugged.	Plug blower back into 115 vac. outlet.
	C) No power at outlet.	Repair service to outlet.
	D) "ON/OFF" switch defective.	Replace switch.
	E) Control harness defective.	Replace control harness.
	F) Blower motor defective.	Replace blower and motor.
	2) Blower running, burner not on	Replace switch.
	A) Fan not running fast enough to close air switch contacts.	Check for low voltage, less than 102 vac., have service checked and repaired.
	B) Air pressure switch defective.	Replace switch.
	C) Gas valve defective.	Replace gas control valve/ thermostat.
	D) Control harness defective.	Replace harness.
	E) Igniter defective.	Replace ignitor.
	F) Unit has completed three trials to light and fail.	Reset cycle by turning switch off and then back on. If unit does not light in three trials, contact a qualified person for service.
	3) Thermostat problems	
	A) Thermostat set too low.	Set temperature control higher.
	B) Thermostat or ECO defective.	Replace gas control valve/thermostat.
	C) High limit control circuit open.	Replace high limit control.
	4) Others	
	A) Heater undersized.	Reduce hot water usage.
B) Low gas pressure.	Contact a qualified person for service.	
C) Incoming water is unusually cold.	Allow more time for heater to re-heat.	
D) Leaking hot water pipes or fixtures.	Have plumber check and repair leaks.	
CONDENSATION	A) Water on the floor under heater.	See "Condensation"
WATER LEAKS	Improperly sealed, hot or cold supply connections, relief valve, drain valve or thermostat threads.	Turn off heater & water, repair unit.
	Leakage from other appliances or water lines.	Inspect other appliances near water heater.
	Condensation of flue products.	Refer to "CONDENSATION"
LEAKING T&P VALVE	Thermal expansion in closed water system	Install thermal expansion tank (DO NOT PLUG T&P VALVE)
	Improperly seated valves	Check relief valve for proper operation (DO NOT PLUG T&P VALVE)
HOT WATER ODORS OR COLOR (Refer to CATHODIC PROTECTION)	High sulfate or mineral content in water supply or iron or sulfate reducing bacteria in water supply	Drain and flush heater thoroughly, chlorinate, refill and flush again then chlorinate water supply.

TROUBLESHOOTING GUIDELINES

TROUBLE SHOOTING

Please check guidelines below. For your safety, water heater service should be performed only by a qualified service technician. Read the GENERAL SAFETY INFORMATION section first.

INTELLI-VENT TROUBLESHOOTING CHART - USER CONTROL

#	LED STATUS	PROBLEM	SOLUTION
1	▼ B C D E F ● ○ ○ ● ○ ○	Inadequate or no earth ground sensed by the Intelli-Vent™ control.	<ol style="list-style-type: none"> 1. Ensure the wall outlet is properly grounded. 2. Ensure all ground connections/wires on the water heater are secure.
2	▼ B C D E F ● ○ ● ○ ● ○	Power supply to Intelli-Vent™ control has reversed polarity or a high resistance to earth ground.	<ol style="list-style-type: none"> 1. Ensure the wall outlet is properly wired. 2. Ensure all internal 120 VAC wiring connections and wiring harness have no reversed wires. 120 VAC "hot" wire must connect to the on/off switch. 3. Ensure the wall outlet is properly grounded. 4. Ensure all ground connections/wires on the water heater are secure.
3	▼ B C D E F ● ○ ● ○ ○ ○	<p>Pressure switch circuit remaining closed for more than 5 seconds after heating cycle begins. Blower does not start.</p> <p>Service Note: Disconnect power - disconnect one wire from the air pressure switch or the vent temperature limit switch. Turn power back on - blower should start.</p>	<ol style="list-style-type: none"> 1. Ensure air pressure switch circuit wiring is correct and the air pressure switch is not jumpered. 2. Secure power to water heater, check continuity of air pressure switch contacts with wires disconnected. <ul style="list-style-type: none"> A If pressure switch contacts show continuity (closed circuit) replace the pressure switch. B If pressure switch contacts are open and all wiring is correct - turn the power off for 10-20 seconds then on again to clear the error code - if the error code persists replace the Intelli-Vent™ control.
4	▼ B C D E F ● ○ ● ○ ○ ●	<p>Pressure switch circuit remains open longer than 5 seconds after the blower is energized. Blower may run continuously in this condition.</p> <p>Service Note: To learn more about performing Air Pressure Switch tests visit our web site www.hotwater.com to download technical bulletin A-023-06 Air Pressure Switches.</p>	<ol style="list-style-type: none"> 1. Ensure the blower is running - check for 120 VAC to the blower when the heating cycle begins, check the wiring. If the control does not energize the blower - replace the Intelli-Vent™ control. If the blower fails to start when energized - replace the blower assembly. 2. Ensure the air pressure switch sensing tube is properly connected - not kinked or damaged. 3. Check continuity of vent temperature limit switch - replace switch if contacts remain open under 160°F (71°C). 4. Ensure the correct size of vent pipe (2", 3", 4") was used per installation manual for vent length. Ensure maximum number of elbows or equivalent feet of vent pipe has not exceeded maximum limits. 5. Ensure there are no obstructions in the vent pipe. 6. Check air pressure switch performance - check pressure with a digital manometer - check continuity of contacts. (see service note in left column) If the switch proves defective - replace the air pressure switch and or the blower assembly as required. 7. If air pressure switch performance test results prove the air pressure switch is working properly and error code 4 persists - replace the Intelli-Vent™ control.
5	▼ B C D E F ● ○ ● ○ ● ●	<p>The Intelli-Vent™ control has detected an open ignitor circuit. Service Note: The resistance (ohms) of a hot surface ignitor will increase over time. If the resistance at room temperature is near 18.8 ohms - consider replacing the ignitor as a preventative measure.</p>	<ol style="list-style-type: none"> 1. Check wiring to the hot surface ignitor - replace ignitor assembly if wiring is damaged or worn. 2. Check ignitor assembly plug and the socket on the Intelli-Vent™ body for good connection. Replace ignitor assembly and/or control if necessary. 3. Check resistance of ignitor at room temperature 77°F (25°C) at the plug end. Replace ignitor if resistance is not within 11.5 and 18.8 ohms at room temperature. 4. If results from the above tests were good and error code 5 persists - replace the Intelli-Vent™ control.

WATER HEATER CONTROL

TROUBLESHOOTING GUIDELINES

TROUBLE SHOOTING

Please check guidelines below. For your safety, water heater service should be performed only by a qualified service technician. Read the GENERAL SAFETY INFORMATION section first.

INTELLI-VENT TROUBLESHOOTING CHART - USER CONTROL

#	LED STATUS	PROBLEM	SOLUTION
WATER HEATER CONTROL	6 ▼ B C D E F ● ○ ○ ● ● ○	Ignition/flame failure. The water heater has reached the maximum number of retries and is currently locked out for one hour. Cycle the power to the water heater off and on to reset. Service Note: The resistance (ohms) of a hot surface ignitor will increase over time. If the resistance at room temperature is near 18.8 ohms - consider replacing the ignitor as a preventative measure.	<ol style="list-style-type: none"> 1. Gas supply is turned off-pressure too low. Ensure supply and manifold gas pressures are within requirements in installation manual. Manifold gas pressure is non-adjustable if pressure is off by more than 0.3" W.C. (75 Pa) replace Intelli-Vent™ control. 2. Low supply voltage - should be 115 -125 VAC. 3. Ensure flame sensor is making good contact with burner flame, ensure flame is steady see #8 below. 4. Ensure the flame sensor is clean - use ultra fine steel wool or Scotch-Brite™ pad to clean flame sensor. 5. Ensure the hot surface ignitor is positioned to provide consistent ignition. 6. Check for any cracks in ignitor assembly ceramic insulators - replace ignitor assembly if damaged. 7. Check resistance of ignitor at room temperature (77°F) (25°C) at the plug end. Replace ignitor if resistance is not within 11.5 and 18.8 ohms at room temperature. 8. Ensure correct size of vent pipe (2", 3", 4") was used per installation manual for vent length. Using larger pipe than required may cause excessive air turbulence in combustion chamber.
	7 ▼ B C D E F ● ○ ○ ○ ● ●	Self diagnostic tests have found a problem with the gas valve driver circuit, internal microprocessor, or other internal circuits.	<ol style="list-style-type: none"> 1. Turn the power off for 10-20 seconds then on again to clear these error codes. 2. If any of these error codes persist or cannot be cleared- replace the Intelli-Vent™ control.
	8 ▼ B C D E F ● ○ ● ● ● ○		
	9 ▼ B C D E F ● ● ● ● ● ●		
	10 ▼ B C D E F ● ○ ○ ○ ○ ●	Flame signal has been sensed out of proper sequence.	<ol style="list-style-type: none"> 1. Turn the power off for 10-20 seconds and then on again to clear this error code. 2. Replace the Intelli-Vent™ control if this error code persists.
	11 ▼ B C D E F ● ○ ○ ● ● ●	Water temperature in the tank has exceeded 195°F (91°C) and has activated the ECO.	<ol style="list-style-type: none"> 1. Turn the power off for 10-20 seconds then on again to clear this error code. 2. Replace the Intelli-Vent™ if the error code persists.
	12 ▼ B C D E F ● ○ ● ● ○ ○	The self diagnostic check detected one or both of the temperature adjust buttons are stuck.	<ol style="list-style-type: none"> 1. Press and release temperature adjust buttons. If above action does not clear error, control will continue to regulate water temperature at last setting. However, settings will no longer be adjustable - the control should be replaced.
	13 ▼ B C D E F ● ○ ● ● ○ ●	The self diagnostic test has detected the water temperature sensor (thermistor) is either open or shorted.	<ol style="list-style-type: none"> 1. Turn power off for 10-20 seconds then on again to clear this error code. 2. Replace the Intelli-Vent™ control if this error code persist.
14 ▼ B C D E F ● ○ ○ ● ○ ●	Self-diagnostic test found a problem with black resistor wire on the ignitor assembly plug; resistor wire is open or shorted. Service Note: To perform this test ohm meter used must be capable of reading up to 2,000,000 ohms. Unless ohm meter used has an auto-range feature resistance should be checked twice. First reading will be taken using an ohms scale above 1,700,000 ohms. Second reading is taken using ohms scale just above 2,000 or 5,000 ohms.	<ol style="list-style-type: none"> 1. Turn off power to the water heater. 2. Insure black resistor wire is not cut, missing, and is installed between pins 3 & 4 of ignitor assembly plug. Replace ignitor assembly if damaged or defective. 3. Unplug ignitor assembly plug from control. Check resistance of black resistor wire between pins 3 & 4 with an ohm meter. <ol style="list-style-type: none"> 3.1 If reading taken is less than 2000 (5000 for date code 0617 through 0709) or more than 1.7 million ohms, replace ignitor assembly. 3.2 If reading taken is between 2000 (5000 for date code 0617 through 0709) and 1.7 million ohms, replace Intelli- Vent™ control. <p>Service Note: Raised ridges on ignitor assembly plug identify #1, #2, and #3 pins. The four-digit date code can be found on side of the controller.</p>	

TROUBLESHOOTING GUIDELINES

TROUBLE SHOOTING

Please check guidelines below. For your safety, water heater service should be performed only by a qualified service technician. Read the GENERAL SAFETY INFORMATION section first.

INTELLI-VENT TROUBLESHOOTING CHART - USER CONTROL

#	LED STATUS	PROBLEM	SOLUTION
15	▼ B C D E F ● ○ ○ ○ ○ ●	The self-diagnostic test determined resistance of the black resistor wire on ignitor assembly plug is not within tolerance.	<ol style="list-style-type: none"> 1. Turn off power to the water heater. 2. Unplug the ignitor assembly plug from the control. Check the resistance of the black resistor wire between pins 3 & 4 with an ohm meter. 2.1 If the reading taken is more than 100,000 (50,000 for data code before 0616; 70,000 for data code 0617 through 0709) ohms replace the ignitor assembly. 2.2 If the reading taken is less than 100,000 (50,000 for data code before 0616; 70,000 for data code 0617 through 0709) ohms replace Intelli-Vent™ control.
16	▼ B C D E F ● ○ ● ● ● ●	Air pressure switch circuit is opening repeatedly during one heating cycle. May be caused by air pressure switch and/or the vent temperature limit switch (these two switches are wired together in a "series" circuit).	<ol style="list-style-type: none"> 1. Ensure air pressure switch hose is not kinked or clogged; ensure the blower housing is clear of any condensation. 2. Check vent temperature limit switch - if it is determined that the vent temperature limit switch is opening its contacts at normal operating temperatures during heating cycle - replace the vent temperature limit switch. 3. Ensure water heater is not over-firing. 3.1 Check burner orifice size and ensure the correct orifice is installed; replace as necessary. 3.2 Check manifold gas pressure and ensure it is within 0.3" W.C. (75 Pa) of listed rating on Intelli-Vent™ control valve. Manifold gas pressure is non-adjustable, if manifold gas pressure is off by more than 0.3" W.C. (75 Pa), replace the Intelli-Vent™ control. 4. Ensure condensate lines are not obstructed. Check and clear all condensate lines including the floor condensate drain line.

WATER HEATER CONTROL

NOTES

NOTES

Limited Warranty

American Water Heater Company, the warrantor, extends the following LIMITED WARRANTY to the owner of this water heater.

1. THE TANK

If the glass-lined tank in this water heater shall prove upon examination by the warrantor to have leaked due to natural corrosion from potable water therein, during the first THREE years after initial installation, the warrantor will supply a complete new American water heater of equivalent size and current model. Some government agencies are requiring energy efficient standards for water heaters. In the event regulations prohibit sale of a model of equivalent size and construction, American Water Heater Company will provide a model which complies with the regulations of your area, in which case the consumer will be charged the difference in price between the like replacement and the energy efficient model required. The warranty on the replacement water heater will be limited to the unexpired term of the original warranty.

2. ALL OTHER PARTS

If within ONE year after initial installation of this water heater, any part or portion shall prove upon examination by the warrantor to be defective in material or workmanship, the warrantor will repair or replace such part or portion at its option.

3. CONDITIONS AND EXCEPTIONS

This warranty shall apply only when the water heater is installed in accordance with local plumbing and building codes, ordinances and regulations, the printed instructions provided with it and good industry practices. In addition, a temperature and pressure relief valve, certified by A.G.A./CGA and approved by the American Society of Mechanical Engineers, must have been installed.

- a. This warranty shall apply only when the heater is:
 - (1) used at temperatures not exceeding the maximum calibrated setting of its thermostat;
 - (2) used at water pressure not exceeding the working pressure shown on the heater;
 - (3) filled with potable water, free to circulate at all times and with the tank free of damaging water sediment or scale deposits;
 - (4) used in a non-corrosive and non-contaminated atmosphere;
 - (5) used with factory approved anode(s) installed;
 - (6) in its original installation location;
 - (7) in the United States, its territories or possessions, and Canada;
 - (8) sized in accordance with proper sizing techniques for commercial and/or residential water heaters;
 - (9) bearing a rating plate which has not been altered, defaced or removed, except as required by the warrantor;
 - (10) used in an open system or in a closed system with properly sized and installed thermal expansion tank;
 - (11) operated with properly installed dirt leg;
 - (12) fired with the fuel for which it was factory built;
 - (13) fired at the factory rated input;
 - (14) operated with the inner and outer combustion chamber doors in place.
- b. Any accident to the water heater, any misuse, abuse (including freezing) or alteration of it, any operation of it in a modified form, any use of insulation blankets, or any attempt to repair tank leaks will void this warranty.
- c. This warranty is void if a device acting as a backflow prevention device (check valves etc.) is installed in the cold water supply the heater is connected to, unless an effective method of controlling thermal expansion is also installed at the heater(s) and operational at all times. The relief valve installed on the heater is not an acceptable method.

4. SERVICE AND REPAIR EXPENSES

Under the limited warranty the warrantor will provide only a replacement water heater or part thereof. The owner is responsible for all other costs. Such costs may include but are not limited to:

- a. Labor charges for service removal, repair or reinstallation of the water heater or any component part;
- b. Shipping, delivery, handling, and administrative charges for forwarding the new heater or replacement part from the nearest distributor and returning the claimed defective heater or part to such distributor.
- c. All cost necessary or incidental for any material and/or permits required for installation of the replacement heater or part.

5. LIMITATIONS ON IMPLIED WARRANTIES

Implied warranties, including the warranty of merchantability imposed on the sale of this heater under state or provincial law are limited to one (1) year duration for the heater or any of its parts. Some states and provinces do not allow limitation on how long an implied warranty lasts, so the above limitation may not apply to you.

6. CLAIM PROCEDURE

Any claim under the warranty should be initiated with the dealer who sold the heater, or with any other dealer handling the warrantor's products. If this is not practicable, the owner should contact:

U.S. Customers
American Water Heater Company
PO Box 1597, 500 Princeton Road
Johnson City, TN 37605

- a. The warrantor will only honor replacement with identical or similar water heater or parts thereof which are manufactured or distributed by the warrantor.
- b. Dealer replacements are made subject to in-warranty validation by warrantor.

7. DISCLAIMERS

NO OTHER EXPRESS WARRANTY HAS BEEN OR WILL BE MADE IN BEHALF OF THE WARRANTOR WITH RESPECT TO THE MERCHANTABILITY OF THE HEATER OR THE INSTALLATION, OPERATION, REPAIR OR REPLACEMENT OF THE HEATER. THE WARRANTOR SHALL NOT BE RESPONSIBLE FOR WATER DAMAGE, LOSS OF USE OF THE UNIT, INCONVENIENCE, LOSS OR DAMAGE TO PERSONAL PROPERTY OR OTHER CONSEQUENTIAL DAMAGE. THE WARRANTOR SHALL NOT BE LIABLE BY VIRTUE OF THIS WARRANTY OR OTHERWISE FOR DAMAGE TO ANY PERSONS OR PROPERTY, WHETHER DIRECT OR INDIRECT, AND WHETHER ARISING IN CONTRACT OR IN TORT.

- a. Some states or provinces do not allow the exclusion or limitation of the incidental or consequential damage, so the above limitations or exclusions may not apply to you.
- b. This warranty gives you specific legal rights, and you may also have other rights which vary from state to state or province to province.

Fill in the following for your own reference. Keep it. Registration is not a condition of warranty. The model and serial number are found on the heater's rating plate.

Model No. _____ Serial No. _____ Date Installed _____
Dealer's Name _____
Dealer's Address _____ Phone No. _____
City and State/Province _____ Zip/Postal Code _____

KEEP THIS WARRANTY POSTED ADJACENT TO THE HEATER FOR FUTURE REFERENCE



P.O. Box 1597, Johnson City, TN 37605
Phone: 800-456-9805 • Fax: 800-999-5210
www.americanwaterheater.com