

PROLINE® ULTRA-LOW NOx HIGH RECOVERY COMMERCIAL-GRADE RESIDENTIAL

CODE COMPLIANCE

- The Ultra-Low NOx atmospheric vent residential gas water heater meets the thermal efficiency and standby loss requirements of the U. S. Department of Energy and Current Edition ASHRAE/IESNA 90.1.

FULLY AUTOMATIC CONTROLS WITH SAFETY SHUTOFF

- Accurate, dependable control system requires no electric connections. Fixed automatic gas shutoff device for added safety. Not recommended for 180°F sanitizing.

HEAVY GAUGE STEEL JACKET

- Finished with baked enamel over bonderized undercoat.

GLASSLINED TANK

- Maximizes tank life.

FOAM INSULATION

- Saves fuel, helps reduce standby heat loss.

ULTRA-LOW NOx EMISSIONS

- Complies with SCAQMD Rule 1146.2 and other Air Quality Management Districts with similar requirements of 14 ng/j or 20 ppm.

EASY-TO-INSTALL

- Completely factory-assembled. Only gas, water and vent connections need to be made. All connections are located in front and top of heaters for ease-of-installation and service.

DRAFT HOOD

- Low profile draft hood furnished as standard equipment.

COREGARD™ ANODE ROD

- Our anode rods have a stainless steel core that extends the life of the anode rod allowing superior tank protection far longer than standard anode rods.

MAXIMUM WORKING PRESSURE

- 150 PSI.

MAXIMUM GAS INLET PRESSURE

- 14" W.C.

FEATURES

- Anodic protection
- Equipped with gas pressure regulator
- Integral automatic gas shutoff system prevents excessive water temperature
- CSA certified and ASME rated T&P relief valve
- The UBG62-75T75-4NV comes standard with side loop fittings for use with hydronic heating applications.

6-YEAR LIMITED TANK AND PARTS WARRANTY

- For complete warranty information, consult written warranty or contact American Water Heaters.



Recovery Ratings														
Model	Input Rate	Recovery in US Gallons/hr or Liters/hr at Indicated Temperature Rise in Fahrenheit or Celsius												
		°F	30	40	50	60	70	80	90	100	110	120	130	140
UG62-75T75-4NV**†	75,100 BTU/h	°F	30	40	50	60	70	80	90	100	110	120	130	140
		GPH	243	182	146	121	104	91	81	73	66	61	56	52
	22 kW	°C	17	22	28	33	39	44	50	56	61	67	72	78
		LPH	919	689	551	459	394	345	316	276	251	230	212	197
UG62-100T75-4NV*	75,100 BTU/h	°F	30	40	50	60	70	80	90	100	110	120	130	140
		GPH	246	184	147	123	105	92	82	74	67	61	57	53
	22 kW	°C	17	22	28	33	39	44	50	56	61	67	72	78
		LPH	930	698	558	465	399	349	310	279	254	233	215	199

*Recovery rating based on 81% thermal efficiency

**Recovery rating based on 80% thermal efficiency

†The UG62-75T75-4NV comes standard with side loop fittings for use with hydronic heating applications

Dimensions														
Model	Units	A	B	C	D	E	F	G	H	J	K	L	M	Approx. Shipping Weight
UG62-75T75-4NV	Inches	62-1/16	58	29-1/2	25-1/4	15-7/8	4	15-1/4	16	2	1	1/2	12-1/2	285 lbs
	CM	157.6	147.3	74.9	64.1	40.3	10.2	38.7	40.6	5.1	NPT	NPT	31.8	129.2 kg
UG62-100T75-4NV	Inches	70-1/2	66-1/2	30-15/16	27-3/4	15-3/16	4	15-3/4	16	1-1/4	1-1/4	1/2	11-15/16	350 lbs
	CM	179.1	168.9	78.6	70.5	38.6	10.2	40	40.6	3.2	NPT	NPT	30.3	158.8 kg

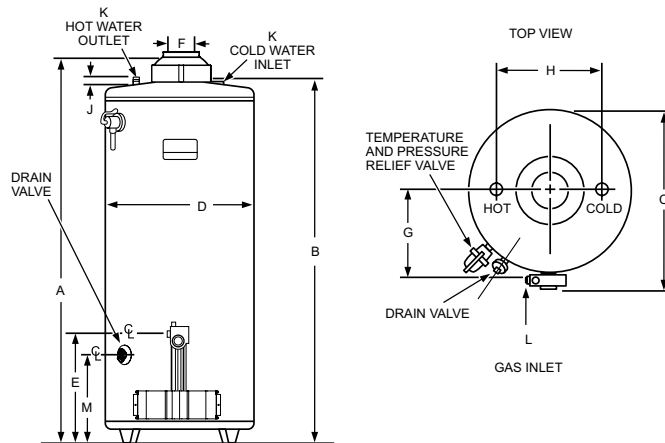

SPECIFICATION

Water heater(s) shall be Model _____ as manufactured by American Water Heaters or an approved equal. Water heater(s) shall be of glasslined design, equipped to burn _____ gas and design certified by UL. Heaters must meet all applicable energy codes and comply with ultra-low NOx emissions of 14 ng/j or 20 ppm. Heaters shall have an input rating of _____ BTU/H and a recovery capacity of _____ GPH at a temperature rise of 100°F with a storage capacity of _____ gallons. Heater shall have a working pressure of 150 psi. Heater(s) shall be provided with an automatic gas shutoff device and safety shutoff in event pilot flame is extinguished; a gas pressure regulator set for the type of gas supplied; an approved draft hood, and extruded anode rod rigidly supported for cathodic protection. A CSA Certified and ASME Rated T&P Relief Valve shall be furnished and installed by the manufacturer. The tank shall be foam insulated. The outer jacket shall have a baked enamel finish over a bonderized undercoating. Fully illustrated instruction manual. All internal surfaces of the heater(s) exposed to water shall be glasslined with an alkaline borosilicate composition that has been fused-to-steel by firing at a temperature range of 1400° to 1600°F. Heater tank shall have a six year limited tank and parts warranty against corrosion and tank failure due to sediment build-up as outlined in the written warranty. Heater(s) shall be design certified by UL. Operation of the heater in a closed system where thermal expansion has not been compensated for with a properly sized expansion tank will void the warranty.

For technical information call (800) 999-9515. American Water Heaters reserves the right to make product changes or improvements without prior notice.