

HEAVY-DUTY BCG3

Heavy-Duty BCG3 is the original money-saving self-cleaning water heater. It provides outstanding performance and installation flexibility for new construction and replacement applications. The Heavy-Duty BCG3 series offers installer-friendly features, including compact low-profile design, multiple options for water connections and low installation clearances.

FACTORY-INSTALLED DRAFT DIVERTER AND AUTOMATIC FLUE DAMPER (BCG3-120-400 MODELS)

- Low-profile draft diverter helps for installation in tight spaces
- Automatic motorized flue damper helps minimize standby heat loss
- BCG3 85T500 Model features induced draft design and no damper

THREE WATER CONNECTION OPTIONS FOR ADDED FLEXIBILITY

- Hot and cold water connections can be made through front, top or back of unit
- Eliminator™ system operates when cold water is connected through front

PERMAGLAS® ULTRA COAT™ GLASS LINING

- Exclusive process provides superior protection against corrosion
- CoreGard™ anode rods with stainless steel core provide additional corrosion protection

INTERMITTENT ELECTRONIC IGNITION

- Eliminates standing pilot, saves energy
- Includes power ON/OFF switch
- Provides flame failure response in less than one second

FACTORY-INSTALLED, CSA CERTIFIED AND ASME RATED T&P RELIEF VALVE

MAXIMUM HYDROSTATIC WORKING PRESSURE: 160 PSI

CODES AND STANDARDS

- Design-certified by UL (Underwriters Laboratories), according to ANSI Z.21.10.3 - CSA 4.3 standards governing storage-type water heaters
- Meets the thermal efficiency and standby loss requirements of the U. S. Department of Energy and current edition of ASHRAE/IESNA 90.1
- Design-certified by Underwriters Laboratories Sanitation to NSF Standard 5 for 180°F (82°C) water
- Optional ASME tank construction available on select models

THE ELIMINATOR™ SELF-CLEANING SYSTEM

- Designed to significantly reduce or eliminate sediment build-up inside the tank
- Reduced sediment build-up maintains rated thermal efficiency and reduces water heating costs
- Self-cleaning system maximizes tank life

3-YEAR LIMITED TANK / 1-YEAR LIMITED PARTS WARRANTY

- For complete warranty information, consult written warranty or go to americanwaterheater.com.



BCG3-70T120-6N through
BCG3-100T390-8N



ON SELECT MODELS



THE ELIMINATOR™ SELF-CLEANING SYSTEM





Commercial Gas Water Heater

OTHER FEATURES

FULLY AUTOMATIC CONTROL SYSTEM

- Manual-reset gas shut-off device prevents excessive water temperature
- Adjustable thermostat with 120°F—180°F range
- Gas pressure regulator and pilot filter

HANDHOLE CLEANOUT

- Allows easy access to tank interior for cleaning

PLUG KITS

- Pipe nipples and caps included to plug unused water connections options:

MANIFOLD KITS FOR MULTIPLE HEATER INSTALLATIONS

- 2-unit kit, Part Number 9003426205
- 3-unit kit, Part Number 9003427205
- 4-unit kit, Part Number 9003428205

OPTIONAL LEG KIT TO MEET NSF STANDARD 5

- For all BCG3 models, Part Number 9003425205

MECHANICAL VENTING KITS

- For BCG3-10120-5N through BCG3-100T200-6N, Part Number 9005381205
- For BCG3-100T250-8N through BCG3-100T390-8N, Part Number 9003434205
- For installation of approved power venter to operate in conjunction with water heater thermostat
- Field wiring should conform to latest version of the National Electric Code ANSI/NFPA No.70
- For more information, consult manual shipped with water heater or contact the American Technical Support Center at 1-800-458-9805

Water Connections in Inches						
Model Number	Inlet			Outlet		
	Top	Front	Back	Top	Front	Back
BCG3-70T120-5N	1-1/2	1-1/2	1-1/2	1-1/2	1-1/2	1-1/2
BCG3-80T150-6N	1-1/2	1-1/2	1-1/2	1-1/2	1-1/2	1-1/2
BCG3-80T180-6N	1-1/2	1-1/2	1-1/2	1-1/2	1-1/2	1-1/2
BCG3-100T199-6N	1-1/2	1-1/2	1-1/2	1-1/2	1-1/2	1-1/2
BCG3-80T199-6N	1-1/2	1-1/2	1-1/2	1-1/2	1-1/2	1-1/2
(A)BCG3-100T200-6N	1-1/2	2	2	1-1/2	2	2
(A)BCG3-100T250-8N	1-1/2	2	2	1-1/2	2	2
(A)BCG3-65T250-8N	N/A	1-1/2	1-1/2	N/A	1-1/2	1-1/2
(A)BCG3-100T275-8N	1-1/2	2	2	1-1/2	2	2
(A)BCG3-65T300-8N	N/A	1-1/2	1-1/2	N/A	1-1/2	1-1/2
(A)BCG3-85T360-8N	1-1/2	1-1/2	1-1/2	1-1/2	1-1/2	1-1/2
(A)BCG3-100T390-8N	1-1/2	2	2	1-1/2	2	2
(A)BCG3-85T500-8N	1-1/2	1-1/2	1-1/2	1-1/2	1-1/2	1-1/2

When ordering LP gas, Change the "N" to "P" in the model number. exp. BCG3-71T120-5P*

Commercial Gas Water Heater

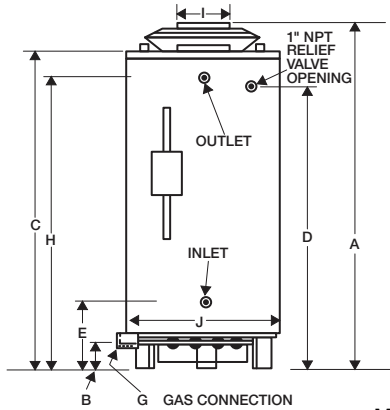

MODELS
BCG3-70T120-5N
Through
BCG3-100T-390-8N

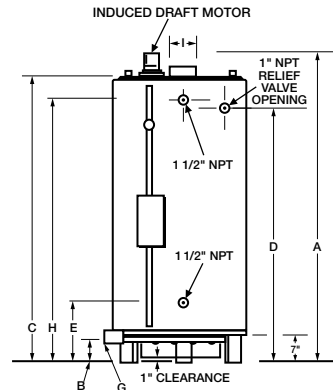
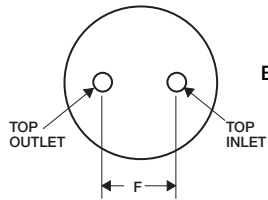

MODEL
BCG3 85T500-8N

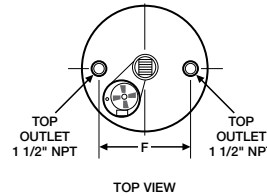

DIMENSIONS

Model Number	Inches or CM	Dimensions										Approx. Shipping Weight	
		A	B	C	D	E	F	G	H	I	J	Standard	ASME
BCG3-70T120-5N*	Inches	69-3/4"	4-1/4"	59-1/2"	50-7/8"	19-11/16"	19"	1/2"	51-7/8"	6"	27-3/4"	400 lbs.	-
	CM	177	11	151	129	50	48	-	132	15	71	182 Kg	-
BCG3-80T150-6N	Inches	73"	4-1/4"	66-1/2"	57-7/8"	19-11/16"	19"	1/2"	59"	6"	27-3/4"	470 lbs.	-
	CM	185	11	169	147	50	48	-	150	15	71	213 Kg	-
BCG3-80T180-6N	Inches	67-1/2"	4-1/2"	62"	53-1/2"	20-1/2"	21"	1/2"	54-5/8"	6"	27-3/4"	470 lbs.	-
	CM	171	12	157	136	52	53	-	139	15	71	213 Kg	-
BCG3-100T199-6N	Inches	75"	4-1/2"	70"	61-1/2"	20-1/2"	21"	1/2"	62-5/8"	6"	27-3/4"	603 lbs.	-
	CM	192	12	178	157	52	53	-	159	15	71	273 Kg	-
BCG3-80T199-6N	Inches	67-1/2"	4-1/2"	62"	53-1/2"	20-1/2"	21"	1/2"	54-1/8"	6"	27-3/4"	470 lbs.	-
	CM	171	12	157	136	52	53	-	139	15	71	213 Kg	-
(A)BCG3-100T200-6N	Inches	72"	4-1/2"	65-1/8"	55-7/8"	19-3/4"	23"	1/2"	56-3/8"	8"	30-1/4"	630 lbs.	725 lbs.
	CM	183	12	165	142	50	58	-	143	20	77	286 Kg	329 Kg
(A)BCG3-100T250-8N**	Inches	72"	4-1/2"	65-1/8"	55-7/8"	19-3/4"	23"	1/2"	56-3/8"	8"	30-1/4"	630 lbs.	725 lbs.
	CM	183	12	165	142	50	58	-	143	20	77	286 Kg	329 Kg
(A)BCG3-65T250-8N**	Inches	75"	4-1/2"	65-3/4"	57-1/4"	20"	N/A	1/2"	58-3/4"	8"	27-3/4"	750 lbs.	862 lbs.
	CM	191	12	167	145	51	N/A	-	149	20	70	341 Kg	391 Kg
(A)BCG3-100T275-8N**	Inches	72"	4-1/2"	65-1/8"	55-7/8"	19-3/4"	23"	1/2"	56-3/8"	8"	30-1/4"	630 lbs.	725 lbs.
	CM	183	12	165	142	50	58	-	143	20	77	286 Kg	329 Kg
(A)BCG3-65T300-8N	Inches	75"	4-1/2"	6-3/4"	57-1/4"	20"	N/A	1/2"	58-3/4"	8"	27.75	750 lbs.	862 lbs.
	CM	191	12	167	145	51	N/A	-	149	20	70	341 Kg	391 Kg
(A)BCG3-85T360-8N	Inches	79-1/2"	4-1/2"	70-1/4"	62-1/2"	22-1/2"	23"	3/4"	63"	8"	27-3/4"	725 lbs.	833 lbs.
	CM	202	12	178	159	57	58	-	160	20	71	329 Kg	379 Kg
(A)BCG3-100T390-8N	Inches	75-1/2"	4-1/2"	67-1/2"	58-1/4"	26-3/4"	23"	3/4"	59"	8"	30-1/4"	760 lbs.	874 lbs.
	CM	192	12	171	148	68	58	-	150	20	77	345 Kg	396 Kg
(A)BCG3-85T500-8N***†	Inches	81-1/2"	17.5"	77-1/4"	67-1/2"	27-1/8"	21"	1"	67-1/2"	8"	27-3/4"	812 lbs.	857 lbs.
	CM	209	44	196	171	69	53	3	171	20	70	368 Kg	389 Kg

When ordering LP gas, Change the "N" to "P" in the model number. exp. BCG3-71T120-5P*

*Model BCG3-100T120-6N is shipped with a 6" x 5" flue outlet adapter.

**Models BCG3-100T250-8N, BCG3-65T250-8N, BCG3-100T275-8N and BCG3-85T500-8N are shipped with a 8" x 6" flue outlet adapter.

Standard models certified for sea level to 2,000 ft. elevation. Order SMR S54 for elevations up to 8,000 ft.

† BCG3-85T500-8N model features induced draft design and no damper.

Back side water connections, Inlet and outlet, are represented by "E" and "H" respectively for height dimensions.



Commercial Gas Water Heater

CAPACITY, INPUT AND OUTPUT

Model Number	Input BTU/HR	Gallons or Litres	Tank Size	Litres	Recovery - Gallons or Litres Per Hour at Degree Rise		
					40°F	100°F	140°F
					22°C	56°C	78°C
BCG3-70T120-5N*	120,000	U.S. Gallons	71	GPH	291	116	83
		Litres	268	LPH	1102	439	314
BCG3-80T150-6N	154,000	U.S. Gallons	81	GPH	373	149	107
		Litres	307	LPH	1412	564	405
BCG3-80T180-6N	180,000	U.S. Gallons	81	GPH	434	174	124
		Litres	307	LPH	1643	659	469
BCG3-100T199-6N	199,000	U.S. Gallons	100	GPH	482	193	132
		Litres	379	LPH	1825	731	500
BCG3-80T199-6N	199,000	U.S. Gallons	81	GPH	482	193	132
		Litres	307	LPH	1825	731	500
(A)BCG3-100T200-6N	199,000	U.S. Gallons	100	GPH	482	193	132
		Litres	379	LPH	1825	731	500
(A)BCG3-100T250-8N**	250,000	U.S. Gallons	100	GPH	606	242	173
		Litres	379	LPH	2294	918	655
(A)BCG3-65T250-8N**	251,000	U.S. Gallons	65	GPH	608	243	174
		Litres	246	LPH	2303	921	658
(A)BCG3-100T275-8N**	275,000	U.S. Gallons	100	GPH	667	267	190
		Litres	379	LPH	2524	1009	721
(A)BCG3-65T300-8N	305,000	U.S. Gallons	65	GPH	739	296	211
		Litres	246	LPH	2799	1120	800
(A)BCG3-85T360-8N	365,000	U.S. Gallons	85	GPH	885	354	253
		Litres	322	LPH	3349	1340	957
(A)BCG3-100T390-8N	390,000	U.S. Gallons	100	GPH	970	388	277
		Litres	379	LPH	3671	1468	1049
(A)BCG3-85T500-8N†**	500,000	U.S. Gallons	85	GPH	1212	485	346
		Litres	322	LPH	4588	1835	1311

When ordering LP gas, Change the "N" to "P" in the model number. exp. BCG3-71T120-5P*

*Model BCG3-100T120-6N is shipped with a 6" x 5" flue outlet adapter.

**Models BCG3-100T250-8N, BCG3-65T250-8N, BCG3-100T275-8N and BCG3-85T500-8N are shipped with a 8" x 6" flue outlet adapter.

Standard models certified for sea level to 2,000 ft. elevation. Order SMR S54 for elevations up to 8,000 ft.

† BCG3-85T500-8N model features induced draft design and no damper.

Recovery based on 80% efficiency.

SPECIFICATION

(Natural or Propane) gas water heater(s) shall be American Heavy-Duty (A)BCG3 model # _____ or equal, with a storage capacity of _____ gallons, an input rating of _____ BTUs per hour, a recovery rating of _____ gallons per hour (gph) at 100°F rise and a maximum hydrostatic working pressure of 160 psi. Water heater(s) shall be protected against overheating caused by the buildup of scale, film and other sediment by a self-cleaning device, positioned inside the tank so that it directs the flow of inlet water to keep precipitated solids in suspension so that they are removed from the water heater on that or successive draws. Glasslined water heater(s) shall also be protected against electrolytic corrosion by multiple factory-installed anode rods. In addition, water heater(s) shall: 1) Be equipped with an integrated control system consisting of a 180°F adjustable thermostat with upper and lower sensing bulbs. 2) Be equipped with intermittent electronic ignition, a manual reset gas shutoff device, a gas pressure regulator, factory-installed, CSA Certified and ASME Rated T&P relief valve and 2-3/4" x 3-3/4" tank inspection port. 3) Be design-certified by UL (Underwriters Laboratories) to current edition of ANSI Z.21.10.3 - CSA 4.3 standards governing storage-type water heaters. 4) Meets the thermal efficiency and standby loss requirements of the U. S. Department of Energy and Current Edition of ASHRAE/ IESNA 90.1. 5) Have a 3-year limited warranty against corrosion as outlined in the written warranty.

For technical information call (800) 456-9805. American Water Heaters reserves the right to make product changes or improvements without prior notice.