

PROLINE® ELECTRONIC THERMOSTAT COMMERCIAL-GRADE RESIDENTIAL

ELECTRONIC THERMOSTAT

- Provides precise temperature control with enhanced sensing and faster heating response.
- Diagnostic (dual color) LED light signals green flash for normal operation and red flash for error fault.
- Element "Dry-Fire" protection intelligence

SMART PORT MODULE

- Allows for grid connectivity via optional CTA-2045 port adapter and 3rd party communication module.
- Can provide Demand Response, Energy Storage and Time of Use saving benefits depending on local utility services offered.

HEATING ELEMENTS

- Dual 4,500 watt elements are standard for fast recovery.
- Upper element has a copper sheath and the lower element is stainless steel for reliable operation.

ENERGY EFFICIENT

- Eco-friendly non-CFC foam insulation, heat traps and other features combine to yield a high Energy Factor to maximize savings.

SELF CLEANING DIP TUBE

- Helps reduce lime and sediment buildup and maximizes hot water output. Made from long-lasting PEX cross-linked polymer.

COREGARD™ ANODE ROD

- Our anode rods have a stainless steel core that extends the life of the anode rod allowing superior tank protection far longer than standard anode rods.

BLUE DIAMOND® GLASS COATING

- Provides superior corrosion resistance compared to industry standard glass lining.

ENHANCED-FLOW BRASS DRAIN VALVE

- Our residential water heaters have a solid brass, tamper resistant, enhanced-flow, ball type, drain valve.

- Uses a standard female hose fitting that allows for fast and easy draining during maintenance.

- Designed for easy operation, this valve includes an integral screwdriver slot that features a ¼ turn (open/close) radius, which not only permits full straight-through water flow but also a quick and positive shut off.

CODE COMPLIANCE

- Meets UBC, CEC and HUD National Codes.
- Meets the thermal efficiency and standby loss requirements of the U.S. Department of Energy and current edition of ASHRAE/IES 90.1.
- Complies with the Federal Energy Conservation Standards effective April 16, 2015, in accordance with the Energy Policy and Conservation Act (EPCA), as amended.

APPROVED FOR MANUFACTURED HOUSING

- All residential electric water heaters are compliant with HUD standards for mobile homes/manufactured housing.

CERTIFIED TO UL 174 FOR HOUSEHOLD ELECTRIC WATER HEATERS

CSA CERTIFIED AND ASME RATED T&P RELIEF VALVE

DESIGN-LISTED BY UNDERWRITERS LABORATORIES

- Certified at 300 psi test pressure and 150 psi working pressure.
- Listed according to UL 174 standards governing storage tank-type electric water heaters.

6-YEAR LIMITED TANK AND PARTS WARRANTY

- For complete information, consult written warranty or go to americanwaterheater.com.





COMMERCIAL-GRADE RESIDENTIAL ELECTRIC WATER HEATERS

Model Number	Nominal Capacity	Rated Storage Volume	First Hour Rating (Gallons)	UEF	Recovery @ 90°F Rise Gallon Per Hour	Element Wattage 240V		Dimensions in Inches			Approx. Shipping Weight (lbs)
						Standard	Maximum	A	B	C	
Tall Models											
EG6N-40H	40	36	59	0.93	25	4500	5500	60-1/4"	53-1/4	20	118
EG6N-50H	50	45	67	0.93	25	4500	5500	60-1/2	51-1/4	22	134
Short Models											
EG6N-40R	40	37	54	0.92	25	4500	5500	49-3/4	40-3/4	20-1/2	109
EG6N-50R	50	46	66	0.92	25	4500	5500	49-1/4	40-1/4	23	161

3/4" water connections on 8" center.

All models are available with top-mounted T&P valve (optional).

Only available for 240V or 208V applications.

208V is only available with 4,500 watt elements.

Equipped as dual element only, no single element configurations available.

Minimum wattage available is 4,500 watt elements.

Dimensions and specifications subject to change without notice in accordance with our policy of continuous product improvement.

SMART PORT MODULE CONNECTION

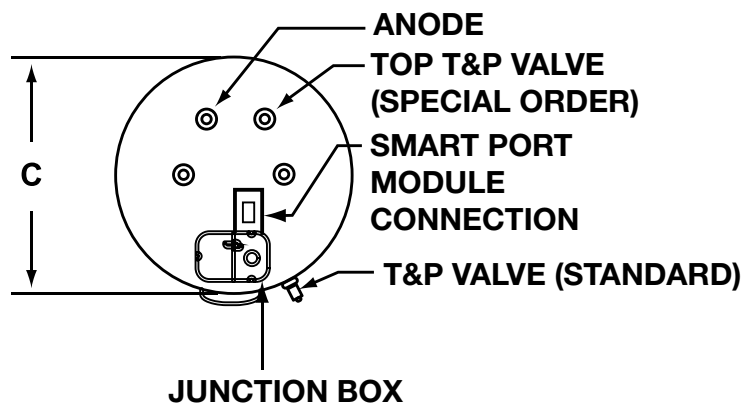
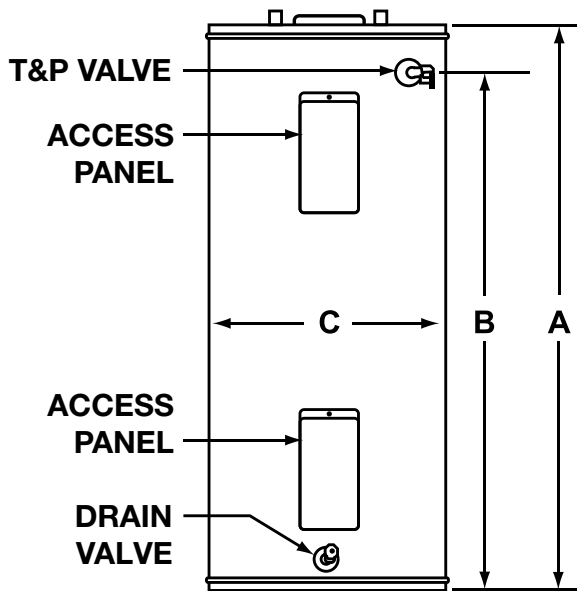

For technical information call (800) 999-9515. American Water Heaters reserves the right to make product changes or improvements without prior notice.