

The diffuser dip tube helps reduce sediment buildup inside the water heater tank to preserve high efficiency output for years of trouble-free service.

12-Year Limited Tank/Parts Warranty*

- **Fused Ceramic Shield**

A tough, thick, durable coat of blue cobalt ceramic is fused to the tank's interior surfaces at 1600°F, forming a corrosion-resistant lining for years of dependable protection and use.

- **Self-Cleaning Diffuser Dip Tube**

Minimizes sediment buildup for long tank life.

- **Dual Incoloy Heating Elements**

Stainless steel sheathed, screw-in, direct immersion, 4500-watt, 240-volt heating elements for maximum efficiency and longer life.

- **Non-CFC Foam Insulation**

The tank is surrounded by a 3" thick coat of non-CFC polyurethane foam to trap heat inside the tank, saving energy.

- **T&P Valve**

Conveniently located on the side of the tank to facilitate piping to a drain or external to the building. Also available with top T&P opening for field installed top T&P valve.

- **3/4" Water Connections**

Located on top.

- **Anode Rod**

Top-mounted, heavy-duty anode for added tank protection, extending the life of the tank.

- **Built-In Electric Junction Box**

Top-located, convenient junction box, ready for 1/2" or 3/4" conduit.

- **Thermostat/High Limit Control**

Combination control allows adjustment of water temperature while preventing overheat protection.

- **Code Approvals**

Listed to UL 174, 1987 NAECA current requirement, BOCA and ASHRAE 90.1- 1999. All models are certified at 300 PSI test pressure and 150 PSI working pressure.

- **Brass Drain Valve**

Durable, tamper-resistant brass drain valve.



*For complete warranty information consult the written warranty of American Water Heaters found at www.americanwaterheater.com, or call (800) 999-9515.

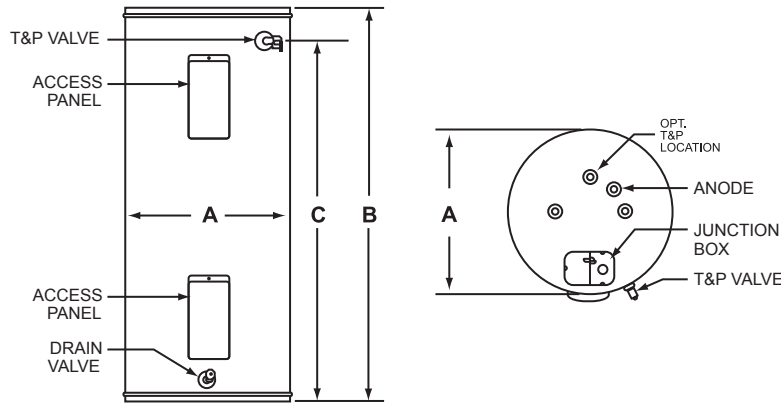

| MODEL NUMBER | GALLON CAPACITY | GPH RECOVERY 90° RISE | EF | JACKET DIAMETER A | HEIGHT TO TOP OF HEATER B | HEIGHT TO SIDE T&P VALVE C | APPROX. SHIPPING WEIGHT |
|-----------------|-----------------|-----------------------|------|-------------------|---------------------------|----------------------------|-------------------------|
| E123-40R-045DHV | 40 | 20.7 | 0.92 | 22 | 47-1/4 | 40-3/4 | 116 |
| E123-40H-045DV | 40 | 20.7 | 0.92 | 20 | 59 | 52-1/2 | 120 |
| E123-50R-045DCV | 50 | 20.7 | 0.93 | 24 | 47-3/4 | 40-3/4 | 142 |
| E123-50H-045DOV | 50 | 20.7 | 0.93 | 22 | 59-1/4 | 51-1/2 | 134 |
| E123-65H-045DCV | 66 | 20.7 | 0.91 | 24 | 60-1/4 | 53 | 168 |
| E123-80H-045DCV | 80 | 20.7 | 0.91 | 26 | 60-1/4 | 53 | 207 |

To order single element substitute "S" for "D" in model number. Delete "V" in model number for top T&P option, T&P opening on top of heater with the valve shipped in the box for field installation. Dimensions and specifications subject to change without notice in accordance with our policy of continuous product improvement. Dimensions on all charts shown in inches. 3/4" water connections on 8" center. All models are wired for non-simultaneous element operation.

Specification

Residential electric water heater(s) shall be model _____ as manufactured by American Water Heaters, or an approved equal, and shall have a _____ year tank warranty and a _____-year parts warranty, when installed in a residential application. Heater(s) shall have a storage capacity of _____ gallons and shall have a rated input of _____ kW at _____ Volts, single phase, 60 cycle AC, and shall be designed, tested and listed in accordance with Underwriter's Laboratories standard UL 174. Heaters shall meet or exceed the requirements of the Federal "National Appliance Energy Conservation Act of 1987" and shall comply with ASHRAE Standard 90.1-1999. The interior of the storage tank shall be lined with a Fused Ceramic Shield lining, fused to the tank at 1600°F, forming a corrosion-resistant lining; polymer linings are not acceptable. Each tank shall be furnished with an internal anode for cathodic protection. The unit must be equipped with a built-in electrical junction box. Electrical heating elements shall be screw-in, direct immersion, resistance type. Element operation shall be controlled by a thermostat for each element. A high temperature cut-off shall be supplied as an integral part of the heater. Element access panels shall be provided on the front of the heater for each element. A durable, tamper-resistant brass drain shall be provided on the front of each unit. The tank shall be totally encased in a metal jacket and insulated with a non-CFC foam to reduce standby heat loss. The tank must be design certified for 300 PSI test pressure and 150 PSI working pressure.

Distributed By:

Order Entry and Sales
 500 Princeton Road (FEDEX, UPS)
 Johnson City, TN 37601-2030
 P.O. Box 4808 (Mailing)
 Johnson City, TN 37602-4808
 (800) 937-1037
 FAX (800) 581-7224

Warranty and Service
 500 Princeton Road (FEDEX, UPS)
 Johnson City, TN 37601-2030
 P.O. Box 1597 (Mailing)
 Johnson City, TN 37605-1597
 (800) 999-9515
 FAX (800) 999-5210