

Residential Gas Water Heater with the Flame Guard™ Safety System Installation Instructions and Use & Care Guide (Flammable Vapor Ignition Resistant)

WARNING: If the information in these instructions is not followed exactly, a fire or explosion may result causing property damage, personal injury or death.

Do not store or use gasoline or other flammable vapors and liquids in the vicinity of this or any other appliance.

WHAT TO DO IF YOU SMELL GAS

- Do not try to light any appliance.
- Do not touch any electrical switch; do not use any phone in your building.
- Immediately call your gas supplier from a neighbor's phone. Follow the gas supplier's instructions.
- If you cannot reach your gas supplier, call the fire department.

Installation and service must be performed by a qualified installer, service agency or the gas supplier.

NATURAL & L.P. GAS MODELS

To obtain technical, warranty, or service assistance during or after the installation of this water heater, or call toll free

1-800-999-9515

When calling for assistance, please have the following information ready:

1. Model number
2. 7 digit product number
3. Serial number
4. Date of installation
5. Place of purchase

Table of Contents 2

INSTALLER:

- AFFIX THESE INSTRUCTIONS TO OR ADJACENT TO THE WATER HEATER.

OWNER:

- RETAIN THESE INSTRUCTIONS AND WARRANTY FOR FUTURE REFERENCE. RETAIN THE ORIGINAL RECEIPT AS PROOF OF PURCHASE.



WATER HEATER SAFETY

Your safety and the safety of others are very important.

We have provided many important safety messages in this manual and on your appliance. Always read and obey all safety messages.



This is the safety alert symbol.

This symbol alerts you to potential hazards that can kill or hurt you and others.

All safety messages will follow the safety alert symbol and either the word "DANGER" or "WARNING." These words mean:

⚠ DANGER

indicates an imminently hazardous situation which, if not avoided, will result in death or injury.

⚠ WARNING

indicates a potentially hazardous situation which, if not avoided, could result in death or injury.

All safety messages will tell you what the potential hazard is, tell you how to reduce the chance of injury, and tell you what can happen if the instructions are not followed.

Important Instructions

- Do not use this appliance if any part has been under water. Immediately call a qualified person. Water heaters subjected to flood conditions or any time the gas controls, main burner or pilot have been submerged in water require replacement of the entire water heater.
- Hydrogen gas can be produced in a hot water system that has not been used for a long period of time (generally two weeks or more). Hydrogen gas is extremely flammable and can ignite when exposed to a spark or flame. To prevent the possibility of injury under these conditions, we recommend the hot water faucet be opened for several minutes at the kitchen sink before using any electrical appliance which is connected to the hot water system. If hydrogen is present, there will probably be an unusual sound such as air escaping through the faucet as water begins to flow. Do not smoke or have any open flame near the faucet at the time it is open.

The California Safe Drinking Water and Toxic Enforcement Act requires the Governor of California to publish a list of substances known to the State of California to cause cancer, birth defects, or other reproductive harm, and requires businesses to warn of potential exposure to such substances.

- **WARNING:** This product contains a chemical known to the State of California to cause cancer, birth defects, or other reproductive harm.
- This appliance can cause low-level exposure to some of the substances listed in the act.

This product is certified to comply with a maximum weighted average of 0.25% lead content as required in some areas.

Table Of Contents

	PAGE
Water Heater Safety	1-2
Installing Your Gas Water Heater	3-15
Unpacking the Water Heater.....	3
Location Requirements.....	4-5
Gas Supply	6-7
Combustion Air Supply and Ventilation.....	7-11
Water System Piping	12-13
Temperature & Pressure Relief Valve.....	14
Special Applications.....	15
Installation Checklist.....	16
Operating Your Water Heater	17-22
Lighting Instructions.....	17
Electrical Connections	20
Operating the Temperature Control System	21
Operational Conditions	22
Maintenance of Your Water Heater	23-28
Troubleshooting Charts	28-32
Repair Parts Illustration	33-34

INSTALLING YOUR GAS WATER HEATER

Important Information About This Water Heater

This gas water heater was manufactured to voluntary safety standards to reduce the likelihood of a flammable vapor ignition incident. New technology used in meeting these standards makes this product more sensitive to installation errors or improper installation environments. Please review the Installation Checklist found at the end of the installation instructions section and make any required installation upgrades or changes.

Consumer Information

This water heater is design-certified by CSA International as a Category I, non-direct vented water heater which takes its combustion air either from the installation area or from air ducted to the unit from the outside.

This water heater must be installed according to all local and state codes or, in the absence of local and state codes, the "National Fuel Gas Code", ANSI Z223.1(NFPA 54)-current edition. This is available from the following:

CSA America, Inc.
8501 East Pleasant Valley Road
Cleveland, OH 44131

National Fire Protection Association
1 Batterymarch Park
Quincy, MA 02269

Check your phone listings for the local authorities having jurisdiction over your installation.

Consumer Responsibilities

This manual has been prepared to acquaint you with the installation, operation, and maintenance of your gas water heater and provide important safety information in these areas.

Read all of the instructions thoroughly before attempting the installation or operation of this water heater.

Do not discard this manual. You or future users of this water heater will need it for future reference.

Service to the Flame Guard™ Safety System should only be performed by a qualified person.

Examples of a qualified person include: licensed plumbers, authorized gas company personnel, and authorized service personnel.

IMPORTANT: The manufacturer and seller of this water heater will not be liable for any damages, injuries, or deaths caused by failure to comply with the installation and operating instructions outlined in this manual.

If you lack the necessary skills required to properly install this water heater, or you have difficulty following the instructions, you should not proceed but have a qualified person perform the installation of this water heater. Massachusetts code requires this water heater to be

installed in accordance with Massachusetts Plumbing and Fuel Gas Code 248 CMR Section 2.00 and 5.00.

A data plate identifying your water heater can be found next to the gas control valve/thermostat. When referring to your water heater, always have the information listed on the data plate readily available.

Retain your original receipt as proof of purchase.

Unpacking the Water Heater

WARNING

Excessive Weight Hazard

Use two or more people to move and install water heater.

Failure to do so can result in back or other injury.

IMPORTANT: Do not remove any permanent instructions, labels, or the data label from either the outside of the water heater or on the inside of water heater panels.

- Remove exterior packaging and place installation components aside.
- Inspect all parts for damage prior to installation and start-up.
- Completely read all instructions before attempting to assemble and install this product.
- After installation, dispose of/recycle all packaging materials.

⚠️ WARNING

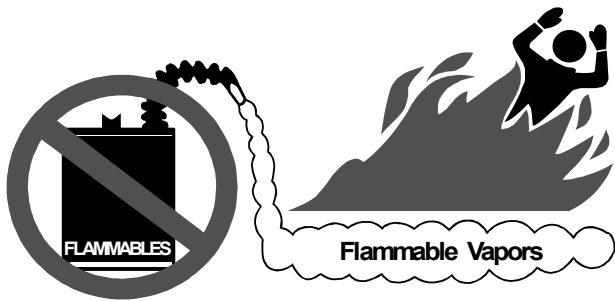

FIRE AND EXPLOSION HAZARD

Can result in serious injury or death



Do not store or use gasoline or other flammable vapors and liquids in the vicinity of this or any other appliance. Storage of or use of gasoline or other flammable vapors or liquids in the vicinity of this or any other appliance can result in serious injury or death.

Read and follow water heater warnings and instructions.

Location Requirements

⚠️ WARNING

Carbon Monoxide Poisoning Hazard

Do not install in a mobile home.

Doing so can result in death or carbon monoxide poisoning.

The FVIR System is designed to reduce the risk of flammable vapor-related fires. Flammable liquids (such as gasoline, solvents, propane, etc.) emit flammable vapors which can be ignited by a gas water heater's spark igniter or main burner. The resulting flashback and fire can cause death or serious burns to anyone in the area.

Figure 1:
FV Sensor

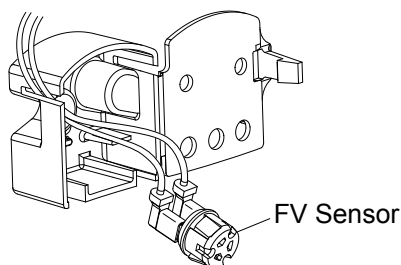

This heater is equipped with an FV sensor for detecting the presence of flammable vapors. When the sensor detects those vapors, the unit will shut down and not operate. Should this happen, please refer to the troubleshooting guide. Even though this water heater is a flammable vapors

ignition resistant water heater and is designed to reduce the chances of flammable vapors being ignited, gasoline and other flammable substances should never be stored or used in the same vicinity or area containing a gas water heater or other open flame or spark producing appliance. In the event the FVIR system does not prevent the ignition of flammable vapors, the Flame Guard™ Safety System is designed to reduce the risk of flammable vapor-related fires.

The patented Flame Guard™ Safety System protects your family by trapping the burning vapors within the water heater combustion chamber through the special flame-trap. The burning vapors literally “burn themselves out” without escaping back into the room. In the event of a flammable vapor incident, the Flame Guard™ Safety System disables the water heater by shutting off the gas supply to the water heater's burner and pilot, preventing re-ignition of any remaining flammable vapors in the area. This will not prevent a possible fire/explosion if the igniter activates and flammable vapors have accumulated in the combustion chamber with the pilot light off. If you suspect a flammable vapor incident has occurred, do not use this appliance. Do not attempt to light this appliance if you suspect flammable vapors have accumulated inside or outside the appliance. Immediately call a qualified person to inspect the appliance. Water heaters subjected to a flammable vapors incident will show a discoloration on the flame-trap and require replacement of the entire water heater. **NOTE:** Not following these instructions and/or an inadequate air supply can cause the Flame Guard™ Safety System to disable the water heater. Please make required installation and venting/air supply changes prior to resetting the system (see “Combustion Air Supply and Ventilation” section). **IMPORTANT:** This water heater has a resettable thermal switch installed as part of the Flame Guard™ Safety System. Do not attempt to disable or modify this feature in any way.

Do not use or store flammable products such as gasoline, solvents, or adhesives in the same room or area near the water heater. If such flammables must be used, all gas burning appliances in the vicinity must be shut off and their pilot lights extinguished. Open the doors and windows for ventilation while flammable substances are in use.

If flammable liquids or vapors have spilled or leaked in the area of the water heater, leave the area immediately and call the fire department from a neighbor's home. Do not attempt to clean the spill until all ignition sources have been extinguished.

Keep combustibles such as boxes, magazines, clothes, etc. away from the water heater area.

Site Location

- Select a location near the center of the water piping system. The water heater must be installed indoors and in a vertical position on a level surface. Do not install in bathrooms, bedrooms, or any occupied room normally kept closed.
- Locate the water heater as close to the chimney or gas vent as practical. Consider the vent system piping and combustion air supply requirements when selecting the water heater location. The venting system must be able to run from the water heater to termination with minimal length and elbows.

- Locate the water heater near the existing gas piping. If installing a new gas line, locate the water heater to minimize the pipe length and elbows.

NOTE: This water heater must be installed according to all local and state codes or, in the absence of local and state codes, the “National Fuel Gas Code”, ANSI Z223.1(NFPA 54)-current edition.

IMPORTANT: The water heater should be located in an area where leakage of the tank or connections will not result in damage to the area adjacent to the water heater or to lower floors of the structure. Due to the normal corrosive action of the water, the tank will eventually leak after an extended period of time. Also any external plumbing leak, including those from improper installation, may cause early failure of the tank due to corrosion if not repaired. If the homeowner is uncomfortable with making the repair a qualified person should be contacted. A suitable metal drain pan should be installed under the water heater as shown below, to help protect the property from damage which may occur from condensate formation or leaks in the piping connections or tank. The pan must limit the water level to a maximum depth of 1-3/4” and be two inches wider than the heater and piped to an adequate drain.

NOTE: The pan must not restrict combustion air flow. Locate the water heater near an adequate indoor drain. The discharge pipe must terminate a maximum of six inches above a floor drain or external to the building. In cold climates, it is recommended that the discharge pipe be terminated at an adequate drain inside the building. Outside drains are subject to freezing temperatures which can obstruct the drain line. The piping should be at least 3/4” ID and pitched for proper drainage. Under no circumstances will the manufacturer or seller of this water heater be held liable for any water damage which is caused by your failure to follow these instructions.

Figure 2
Drain Pan
Installation

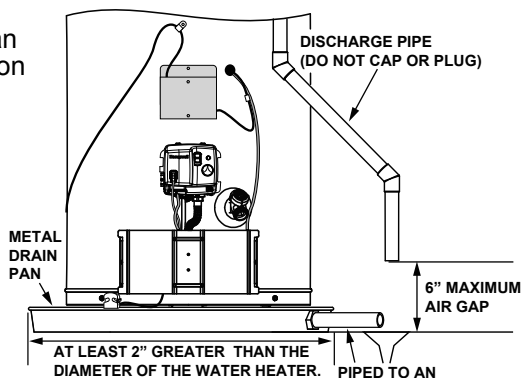

- The water heater should be located in an area not subject to freezing temperatures. Water heaters located in unconditioned spaces (i.e., attics, basements, etc.) may require insulation of the water piping and drain piping to protect against freezing. The drain and controls must be easily accessible for operation and service. Maintain proper clearances as specified on the data plate.
- Do not locate the water heater near an air-moving device. The operation of air-moving devices such as exhaust fans, ventilation systems, clothes dryers, fireplaces, etc., can affect the proper operation of the water heater. Special attention must be given to

conditions these devices may create. Flow reversal of flue gases may cause an increase of carbon monoxide inside of the dwelling.

- If the water heater is located in an area that is subjected to lint, dirt, and oil, it may be necessary to periodically clean the flame-trap (see “External Inspection & Cleaning of the Flame-trap” section).

Figure 3
Air-moving
Devices

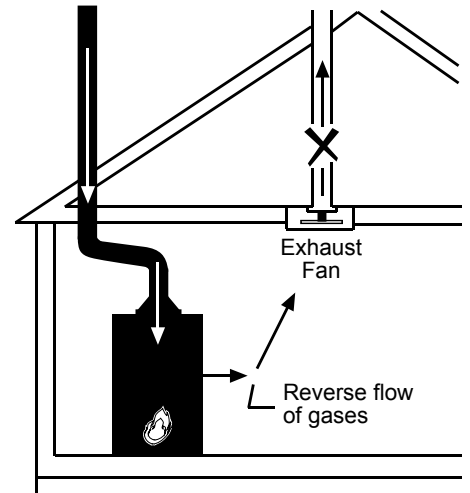

Clearances and Accessibility

NOTE: Minimum clearances from combustible surfaces are stated on the data plate adjacent to the gas control valve/ thermostat of the water heater.

The water heater is certified for installation on a combustible floor.

- **IMPORTANT:** If installing over carpeting, the carpeting must be protected by a metal or wood panel beneath the water heater. The protective panel must extend beyond the full width and depth of the water heater by at least three inches (76.2mm) in any direction; or if in an alcove or closet installation, the entire floor must be covered by the panel.
- Figure 4 may be used as a reference guide to locate the specific clearance locations. A minimum of 24 inches of front clearance should be provided for inspection and service.

Figure 4
Minimum Clearance
Locations

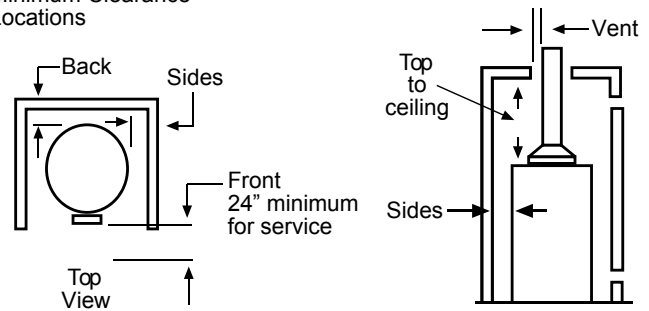

State of California

NOTE: For California installation, this water heater must be braced, anchored, or strapped to avoid falling or moving during an earthquake. Correct installation procedure instructions may be obtained from California’s Office of the State Architect, 1102 Q street, Suite 5100, Sacramento, CA 95811. Instructions can also be downloaded to your computer at www.dsa.dgs.ca.gov/Pubs.

Gas Supply

⚠ WARNING



Explosion Hazard

Use a new CSA approved gas supply line.

Install a shut-off valve.

Do not connect a natural gas water heater to an L.P. gas supply.

Do not connect an L.P. gas water heater to a natural gas supply.

Failure to follow these instructions can result in death, explosion, or carbon monoxide poisoning.

Gas Requirements

IMPORTANT: Read the data plate to be sure the water heater is made for the type of gas you will be using in your home. This information will be found on the data plate located near the gas control valve/thermostat. If the information does not agree with the type of gas available, do not install or light. Call your dealer.

NOTE: An odorant is added by the gas supplier to the gas used by this water heater. This odorant may fade over an extended period of time. Do not depend upon this odorant as an indication of leaking gas.

Gas Piping

The gas piping must be installed according to all local and state codes or, in the absence of local and state codes, the "National Fuel Gas Code", ANSI Z223.1(NFPA 54)-current edition.

Tables 1 and 2 on page 7 provides a sizing reference for commonly used gas pipe materials. Consult the "National Fuel Gas Code" for the recommended gas pipe size of other materials.

Refer to Figure 5

NOTE: When installing gas piping, apply approved pipe joint compound.

1. Install a readily accessible manual shut-off valve in the gas supply line as recommended by the local utility. Know the location of this valve and how to turn off the gas to this unit.
2. Install a sediment trap (if not already incorporated as part of the water heater) as shown. The sediment trap must be no less than three inches long for the accumulation of dirt, foreign material, and water droplets.
3. Install a ground joint union between the gas control valve/thermostat and the manual shut-off valve. This is to allow easy removal of the gas control valve/thermostat.
4. Turn the gas supply on and check for leaks. Test all connections by brushing on an approved noncorrosive leak-detection solution. Bubbles will show a leak. Correct any leak found.

Figure 5
Gas Piping

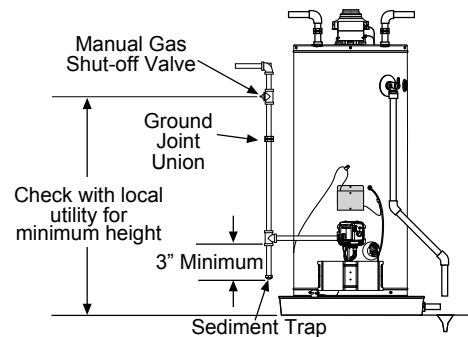

Gas Pressure

IMPORTANT: The gas supply pressure must not exceed the maximum supply pressure as stated on the water heater's data plate. The minimum supply pressure is for the purpose of input adjustment.

Gas Pressure Testing

IMPORTANT: This water heater and its gas connection must be leak tested before placing the appliance in operation.

- If the code requires the gas lines to be tested at a pressure exceeding 14" W.C., the water heater and its manual shut-off valve must be disconnected from the gas supply piping system and the line capped.
- If the gas lines are to be tested at a pressure less than 14" W.C., the water heater must be isolated from the gas supply piping system by closing its manual shut-off valve.

U.L. recognized fuel gas and carbon monoxide (CO) detectors are recommended in all applications and should be installed using the manufacturer's instructions and local codes, rules, or regulations.

NOTE: Air may be present in the gas lines and could prevent the pilot from lighting on initial start-up. The gas lines should be purged of air by a qualified person after installation of the gas piping system. While purging the gas piping system of air, make sure that the fuel is not spilled in the area of the water heater installation, or any source of ignition. If the fuel is spilled while purging the piping system of air follow the "WHAT TO DO IF YOU SMELL GAS" instructions on the cover of this manual.

LP Gas Only

⚠ WARNING



Explosion Hazard

Have a qualified person make sure L.P. gas pressure does not exceed 13" water column.

Examples of a qualified person include: licensed plumbers, authorized gas company personnel, and authorized service personnel.

Failure to do so can result in death, explosion, or fire.

Table 1
Natural Gas Pipe Capacity Table (Cu. Ft./Hr.)
 Capacity of gas pipe of different diameters and lengths in cu. ft. per hr. with pressure drop of 0.3 in. and specific gravity of 0.60 (natural gas).

Nominal Iron Pipe Size, in.	Length of Pipe, Feet													
	10	20	30	40	50	60	70	80	90	100	125	150	175	200
1/2	132	92	73	63	56	50	46	43	40	38	34	31	28	26
3/4	278	190	152	130	115	105	96	90	84	79	72	64	59	55
1	520	350	285	245	215	195	180	170	160	150	130	120	110	100
1-1/4	1050	730	590	500	440	400	370	350	320	305	275	250	225	210
1-1/2	1600	1100	890	760	670	610	560	530	490	460	410	380	350	320

After the length of pipe has been determined, select the pipe size which will provide the minimum cubic feet per hour required for the gas input rating of the water heater. By formula:

$$\text{Cu. Ft. Per Hr. Required} = \frac{\text{Gas Input of Water Heater (BTU/HR)}}{\text{Heating Value of Gas (BTU/FT}^3\text{)}}$$

The gas input of the water heater is marked on the water heater data plate. The heating value of the gas (BTU/FT³) may be determined by consulting the local natural gas utility.

Table 2
LP Gas Capacity Table
 Maximum capacity of pipe in thousands of BTU per hour of undiluted liquefied petroleum gases (at 11 inches water column pressure). Based on a pressure drop of 0.5 inch water column.

Nominal Iron Pipe Size, in.	Length of Pipe, Feet												
	10	20	30	40	50	60	70	80	90	100	125	150	
1/2	275	189	152	129	114	103	96	89	83	78	69	63	
3/4	576	393	315	267	237	217	196	185	173	162	146	132	
1	1071	732	590	504	448	409	378	346	322	307	275	252	
1-1/4	2205	1496	1212	1039	913	834	771	724	677	630	567	511	

Example: Input BTU requirement of the water heater 100,000 BTU/HR.
 Total pipe length, 80 feet = 3/4" IPS required.

Additional tables are available in the latest edition of the "National Fuel Gas Code", ANSI Z223.1.

Combustion Air Supply and Ventilation

⚠ WARNING

Carbon Monoxide Hazard

Water heater must be vented to outdoors.

Vent must be installed by a qualified person using the installation instructions.

Examples of a qualified person include: gas technicians, authorized gas company personnel, and authorized service persons.

Failure to follow these instructions can result in death or carbon monoxide poisoning.

IMPORTANT: Air for combustion and ventilation must not come from a corrosive atmosphere. Any failure due to corrosive elements in the atmosphere is excluded from warranty coverage.

The following types of installation (not limited to the following) will require outdoor air for combustion due to chemical exposure and may reduce but not eliminate the presence of corrosive chemicals in the air:

- beauty shops
- photo processing labs
- buildings with indoor pools
- water heaters installed in laundry, hobby, or craft rooms
- water heaters installed near chemical storage areas

Combustion air must be free of acid-forming chemicals such as sulfur, fluorine, and chlorine. These elements are found in aerosol sprays, detergents, bleaches, cleaning solvents, air fresheners, paint, and varnish removers, refrigerants, and many other commercial and household products. When burned, vapors from these products form highly corrosive acid compounds. These products should not be stored or used near the water heater or air inlet.

Combustion and ventilation air requirements are determined by the location of the water heater. The water heater may be located in either an open (unconfined) area or in a confined area or small enclosure such as a closet or small room. Confined spaces are areas with less than 50 cubic feet for each 1,000 BTU/HR of the total input for all gas-using appliances.

Unconfined Space

A water heater in an unconfined space uses indoor air for combustion and requires at least 50 cubic feet for each 1,000 BTU/HR of the total input for all gas appliances. The table below shows a few examples of the minimum square footage (area) required for various BTU/HR inputs.

BTU/HR Input	Minimum Square Feet with 8' Ceiling	Typical Room with 8' Ceiling
30,000	188	9 x 21
45,000	281	14 x 20
60,000	375	15 x 25
75,000	469	15 x 31
90,000	563	20 x 28
105,000	657	20 x 33
120,000	750	25 x 30
135,000	844	28 x 30

IMPORTANT:

- The area must be open and be able to provide the proper air requirements to the water heater. Areas that are being used for storage or contain large objects may not be suitable for water heater installation.
- Water heaters installed in open spaces in buildings with unusually tight construction may still require outdoor air to function properly. In this situation, outside air openings should be sized the same as for a confined space.
- Modern home construction usually requires supplying outside air into the water heater area.

Confined Space

For the correct and proper operation of this water heater, ample air must be supplied for the combustion, ventilation, and dilution of flue gases. Small enclosures and confined areas must have two permanent openings so that sufficient fresh air can be drawn from outside of the enclosure. One opening shall be within 12 inches of the top and one within 12 inches of the bottom of the enclosure as shown in Figure 6.

The size of each opening (free area) is determined by the total BTU/HR input of all gas utilization equipment (i.e., water heaters, furnaces, clothes dryers, etc.) and the method by which the air is provided. The BTU/HR input can be found on the water heater data plate. Additional air can be provided by two methods:

1. All air from inside the building.
2. All air from outdoors.

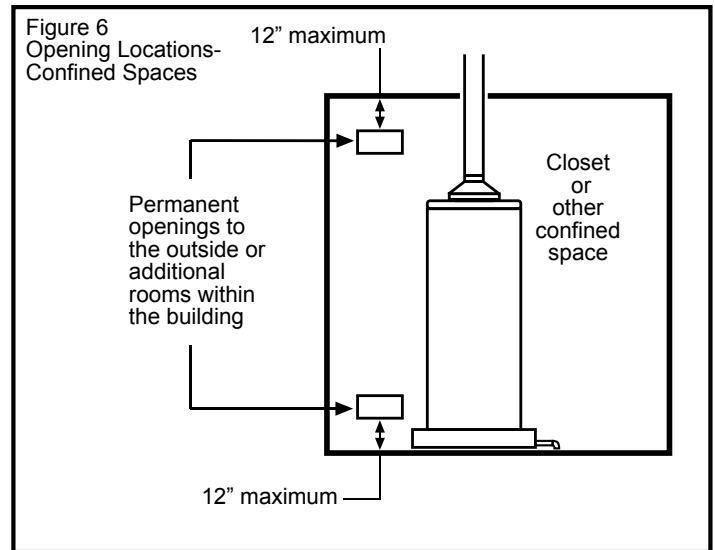

All Air from Inside the Building

When additional air is to be provided to the confined area from additional room(s) within the building, the total volume of the room(s) must be of sufficient size to properly provide the necessary amount of fresh air to the water heater and other gas utilization equipment in the area. If you are unsure that the structure meets this requirement, contact your local gas utility company or other qualified agency for a safety inspection.

Each of the two openings shall have a minimum free area of 1 square inch per 1,000 BTU/HR of the total input rating of all gas utilization equipment in the confined area, but not less than 100 square inches (Figure 7).

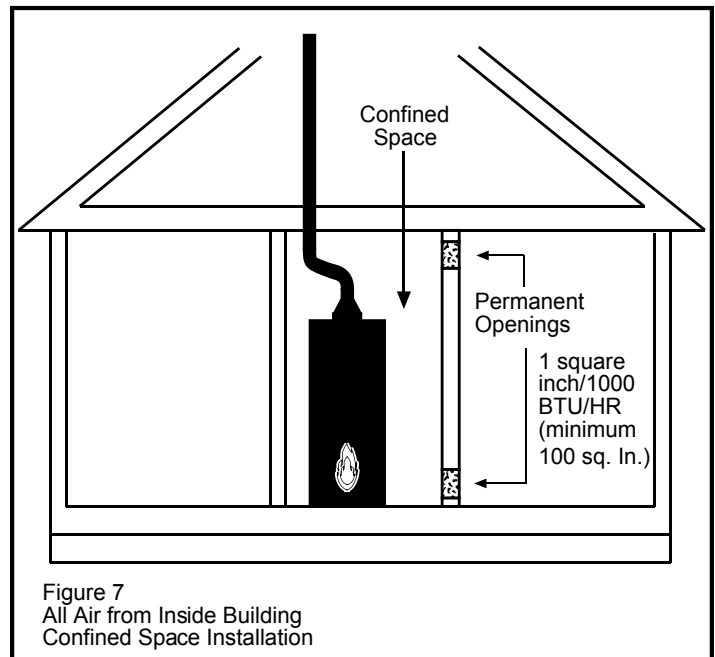

All Air from Outdoors

Outdoor fresh air can be provided to a confined area either directly or by the use of vertical and horizontal ducts. The fresh air can be taken from the outdoors or from crawl or attic spaces that freely communicate with the outdoors. Attic or crawl spaces cannot be closed and must be properly ventilated to the outside.

Ductwork must be of the same cross-sectional area as the free area of the opening to which they connect. The minimum dimension of rectangular air ducts cannot be less than three inches.

The size of each of the two openings is determined by the method in which the air is to be provided. Refer to Table 4 to calculate the minimum free area for each opening. Figures 8, 9, and 10 are typical examples of each method.

Louvers and Grilles

In calculating free area for ventilation and combustion air supply openings, consideration must be given to the blocking effect of protection louvers, grilles, and screens. These devices can reduce airflow, which in turn may require larger openings to achieve the required minimum free area. Screens must not be smaller than 1/4" mesh. If the free area through a particular design of louver or grille is known, it should be used in calculating the specified free area of the opening. If the design and free area are not known, it can be assumed that most wood louvers will allow 20 - 25% of free area while metal louvers and grilles will allow 60 - 75% of free area.

Louvers and grilles must be locked open or interconnected with the equipment so that they are opened automatically during equipment operation.

Keep louvers and grilles clean and free of debris or other obstructions.

Table 4 Minimum Free Area of Permanent Openings for Ventilation and Combustion Air Supply - All Air from Outdoors Only. Based on the total BTU/HR input rating for all utilizing equipment within the confined space.		
Opening Source	Minimum Free Area Per Opening (sq. in.)	Reference Drawing
* Direct to outdoors	1 sq. in. per 4000 BTU/HR	Figure 8
Vertical ducts	1 sq. in. per 4000 BTU/HR	Figure 9
Horizontal ducts	1 sq. in. per 2000 BTU/HR	Figure 10
Single Opening	1 sq. in. per 3000 BTU/HR	Figure 11
Example: A water heater with an input rate of 50,000 BTU/HR using horizontal ducts would require each opening to have a minimum free area of 25 square inches. Minimum free area = 50,000 BTU/HR x 1 sq. in. / 2000 BTU/HR = 25 Sq. Inches.		

* These openings connect directly with the outdoors through a ventilated attic, a ventilated crawl space, or through an outside wall.

Consult the local codes of your area for specific ventilation and combustion air requirements.

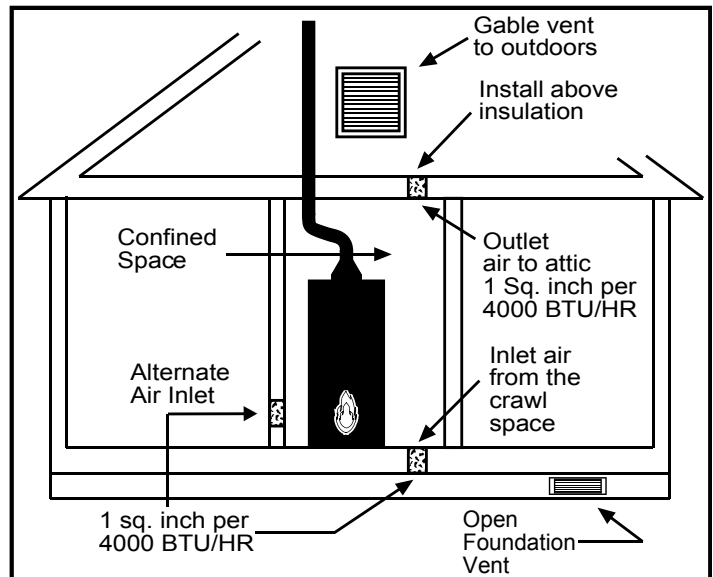

Figure 8
All Air from Outdoors; Inlet Air from Ventilated Crawl Space/Outlet Air to Ventilated Attic

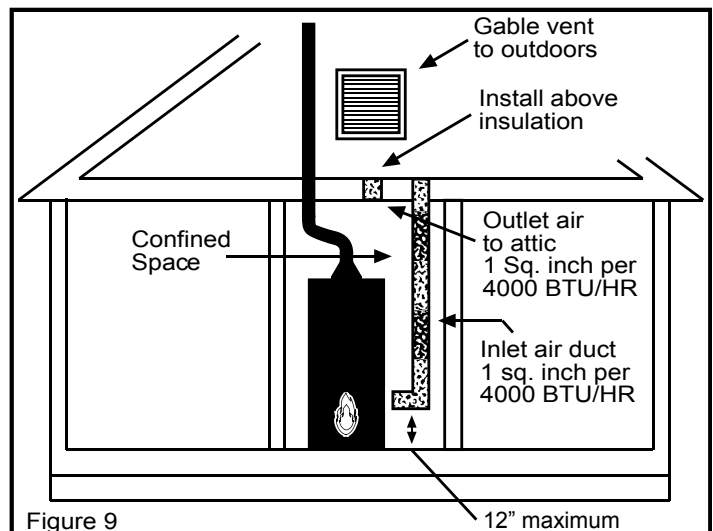

Figure 9
All Air from Outdoors Through Ventilated Attic

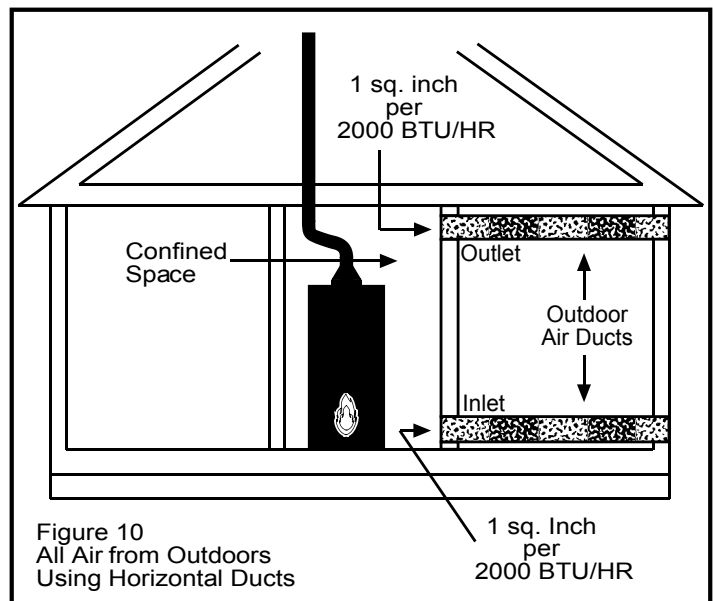

Figure 10
All Air from Outdoors Using Horizontal Ducts

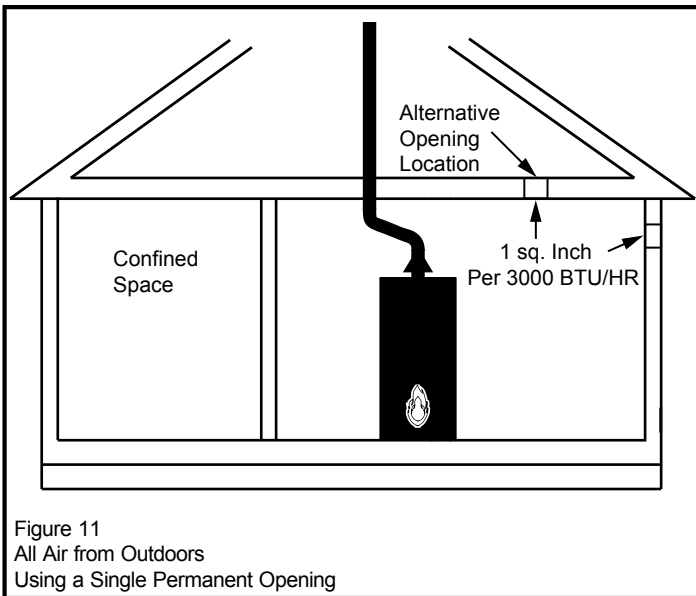
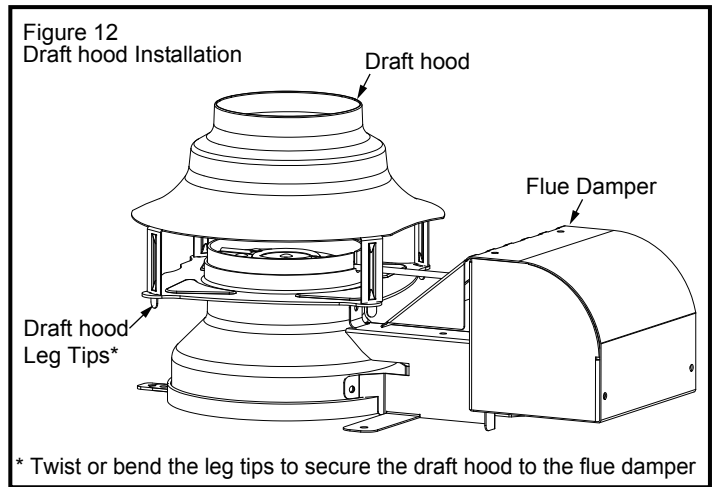

Figure 11
All Air from Outdoors
Using a Single Permanent Opening



* Twist or bend the leg tips to secure the draft hood to the flue damper

Vent Pipe System

This water heater uses a non-direct, single-pipe vent system to remove exhaust gases created by the burning of fossil fuels. Air for combustion is taken from the immediate water heater location or is ducted in from the outside (see “Combustion Air Supply and Ventilation” section).

This water heater must be properly vented for the removal of exhaust gases to the outside atmosphere. Correct installation of the vent pipe system is mandatory for the proper and efficient operation of this water heater and is an important factor in the life of the unit.

The vent pipe must be installed according to all local and state codes or, in the absence of local and state codes, the “National Fuel Gas Code”, ANSI Z223.1(NFPA 54)-current edition. The vent pipe installation must not be obstructed so as to prevent the removal of exhaust gases to the outside atmosphere.

IMPORTANT: The use of vent dampers is not recommended by the manufacturer of this water heater. Although some vent dampers are certified by CSA International, this certification applies to the vent damper device only and does not mean they are certified for use on this water heater.

U.L. recognized fuel gas and carbon monoxide (CO) detectors are recommended in all applications and should be installed using the manufacturer’s instructions and local codes, rules, or regulations.

IMPORTANT: If you lack the necessary skills required to properly install this venting system, you should not proceed, but get help from a qualified person.

Draft Hood Installation

Align the legs of the draft hood with the slots provided. Insert the draft hood leg tips into slots on the flue dampers flange as shown in Figure 12. Secure the draft hood by twisting or bending the leg tips. See Figure 12. Do not alter the draft hood in any way. If you are replacing an existing water heater, be sure to use the new draft hood supplied with the water heater.

Vent Pipe Size

It is important that you follow the guidelines in these instructions for sizing a vent pipe system. If a transition to a larger vent size is required, the vent transition connection must be made at the draft hood outlet.

Vent Connectors

1. Type B, Double wall, U.L. Listed Vent Pipe.
2. Single wall Vent Pipe.

Maintain the manufacturer’s specified minimum clearance from combustible materials when using type B double wall vent pipe.

Vent connectors made of type B, double wall vent pipe material may pass through walls or partitions constructed of combustible material if the minimum listed clearance is maintained.

Maintain a six inch minimum clearance from all combustible materials when using single wall vent pipe.

IMPORTANT: Single wall vent pipe cannot be used for water heaters located in attics and may not pass through attic spaces, crawl spaces or any confined or inaccessible location. A single wall metal vent connector cannot pass through any interior wall.

When installing a vent connector, please note the following:

- Install the vent connector avoiding unnecessary bends, which create resistance to the flow of vent gases.
- Install without dips or sags with an upward slope of at least 1/4-inch per foot.
- Joints must be fastened by sheet metal screws or other approved means. It must be supported to maintain clearances and prevent separation of joints and damage.
- The length of the vent connector cannot exceed 75% of the vertical vent height.
- The vent connector must be accessible for cleaning, inspection, and replacement.
- Vent connectors cannot pass through any ceiling, floor, firewall, or fire partition.
- It is recommended (but not mandatory) that a minimum 12 inches of vertical vent pipe be installed on the draft hood prior to any elbow in the vent system to improve conditions for positive flow of venting gases.

IMPORTANT: Existing vent systems must be inspected for obstructions, corrosion, and proper installation.

Chimney Connection

IMPORTANT: Before connecting a vent to a chimney, make sure the chimney passageway is clear and free of obstructions. The chimney must be cleaned if previously used for venting solid fuel appliances or fireplaces. Also consult local and state codes for proper chimney sizing and application or, in the absence of local and state codes, the "National Fuel Gas Code", ANSI Z223.1(NFPA 54)-current edition.

- The connector must be installed above the extreme bottom of the chimney to prevent potentially blocking the flue gases.
- The connector must be firmly attached and sealed to prevent it from falling out.
- To aid in removing the connector, a thimble or slip joint may be used.
- The connector must not extend beyond the inner edge of the chimney as it may restrict the space between it and the opposite wall of the chimney (Figure 13).

Do not terminate the vent connector in a chimney that has not been certified for this purpose. Some local codes may prohibit the termination of vent connectors in a masonry chimney.

Vertical Exhaust Gas Vent

Vertical exhaust gas vents must be installed with U.L. listed type B vent pipe according to the vent manufacturer's instructions and the terms of its listing.

It must be connected to the water heater's draft hood by a listed vent connector or by directly originating at the draft hood opening.

Vertical gas vents must terminate with a listed cap or other roof assembly and be installed according to their manufacturer's instructions.

Gas vents must be supported to prevent damage, joint separation, and maintain clearances to combustible materials (Figures 14 and 15).

IMPORTANT: This gas vent must be terminated in a vertical position to facilitate the removal of the burnt gases.

An unused chimney flue or masonry enclosure may be used as a passageway for the installation of a gas vent (Figure 15).

Common (combined) venting is allowable with vertical type B vent systems and lined masonry chimneys as long as proper draft for the water heater is established under all conditions of operation.

IMPORTANT: Do not common vent this water heater with any power vented appliance.

Figures 13-15 are examples of vent pipe system installations and may or may not be typical for your specific application. Consult the "National Fuel Gas Code", NFPA 54, ANSI Z223.1-current edition and the guidelines set forth by prevailing local codes.

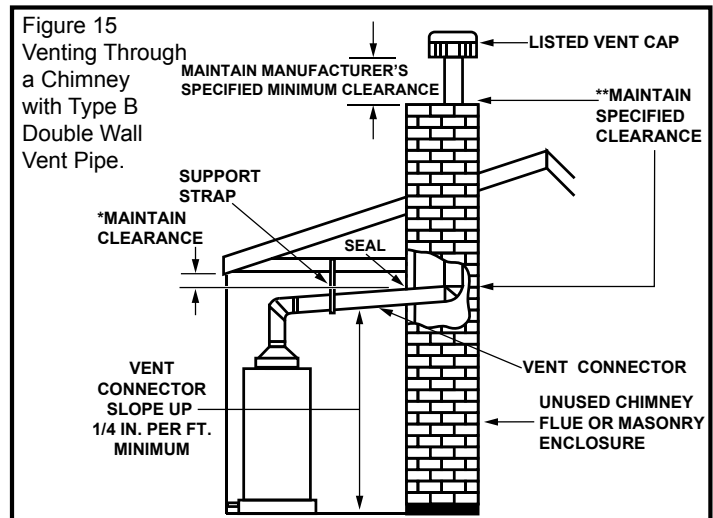
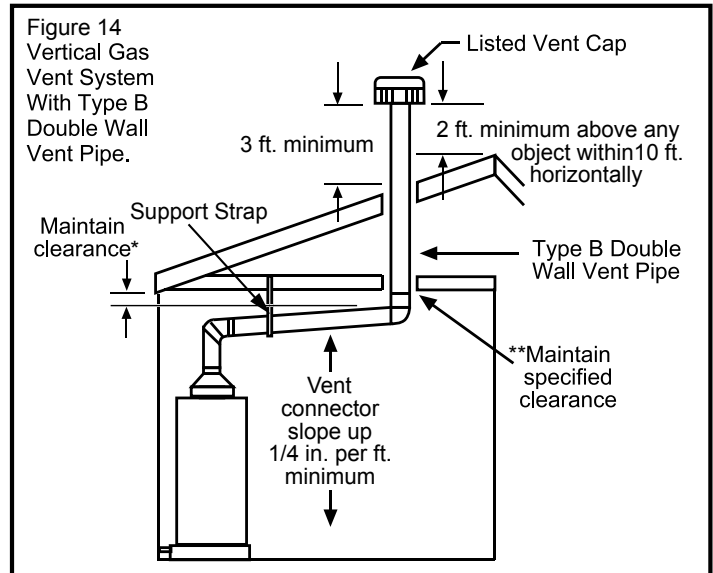
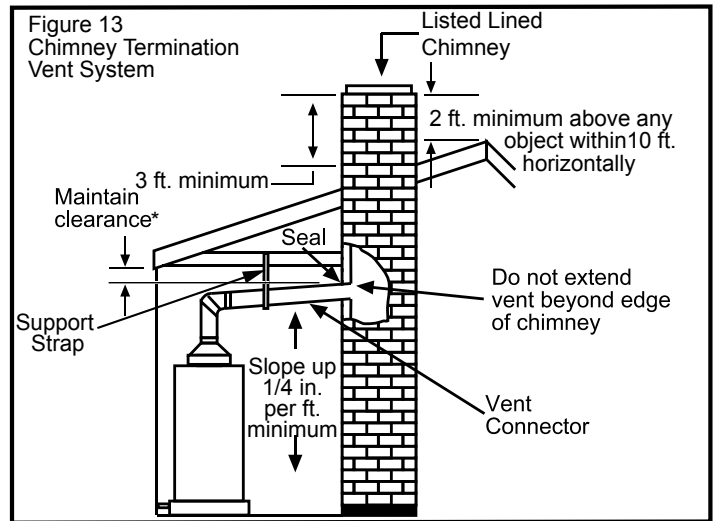

* Maintain vent pipe clearance requirements to local, state and/or the "National Fuel Gas Code", ANSI Z223.1(NFPA 54)-current edition.

** NFPA 211, Standard for Chimneys, Fireplaces, Vents, and Solid Fuel-Burning Appliances states that these chimneys are intended to be installed in accordance with the installation instructions provided with each chimney support assembly. Minimum air space clearance to combustible materials should be maintained as marked on the chimney sections.

Water System Piping

Piping Installation

Piping, fittings, and valves should be installed according to the installation drawing (Figure 16). If the indoor installation area is subject to freezing temperatures, the water piping must be protected by insulation.

The water supply pressure should not exceed 80 psi. If this occurs, a pressure reducing valve with a bypass should be installed in the cold water inlet line. This should be placed on the supply to the entire house in order to maintain equal hot and cold water pressures.

IMPORTANT: Heat cannot be applied to the water fittings on the heater as they may contain nonmetallic parts. If solder connections are used, solder the pipe to the adapter before attaching the adapter to the hot and cold water fittings.

IMPORTANT: Always use a good grade of joint compound and be certain that all fittings are drawn up tight.

1. Install the water piping and fittings as shown in Figure 16. Connect the cold water supply (3/4" NPT) to the fitting marked "C". Connect the hot water supply (3/4" NPT) to the fitting marked "H".

IMPORTANT: Some models may contain energy saving heat traps to prevent the circulation of hot water within the pipes. Do not remove the inserts within the heat traps.

2. The installation of unions in both the hot and cold water supply lines is recommended for ease of removing the water heater for service or replacement.
3. The manufacturer of this water heater recommends installing a mixing valve or an anti-scald device in the domestic hot water line as shown in Figure 17. These valves reduce the point-of-use temperature of the water by mixing cold and hot water and are readily available for use.
4. If installing the water heater in a closed water system, install an expansion tank in the cold water line as specified under "Closed System/Thermal Expansion" section.
5. Install a shut-off valve in the cold water inlet line. It should be located close to the water heater and be easily accessible. Know the location of this valve and how to shut off the water to the heater.
6. A temperature and pressure relief valve must be installed in the opening marked "Temperature and Pressure (T & P) Relief Valve" on the water heater. A discharge line must be added to the opening of the T&P Relief Valve. Follow the instructions under "Temperature and Pressure Relief Valve" section.

7. After piping has been properly connected to the water heater, remove the aerator at the nearest hot water faucet. Open the hot water faucet and allow the tank to completely fill with water. To purge the lines of any excess air, keep the hot water faucet open for 3 minutes after a constant flow of water is obtained. Close the faucet and check all connections for leaks.

Figure 16
Water Piping Installation

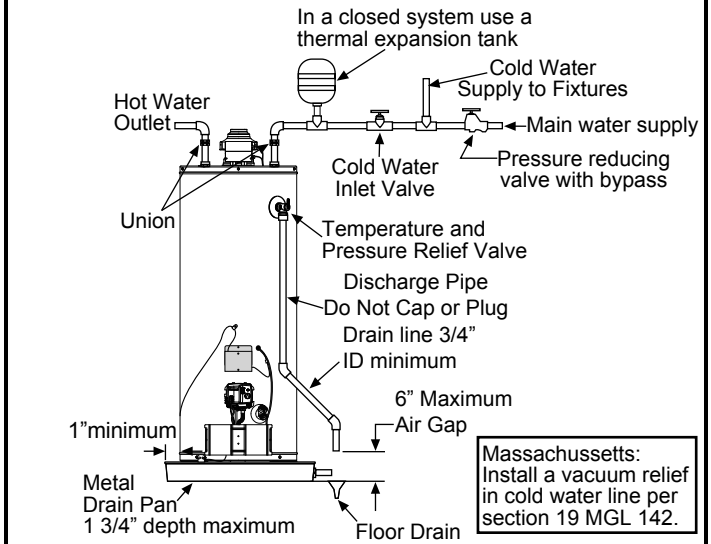
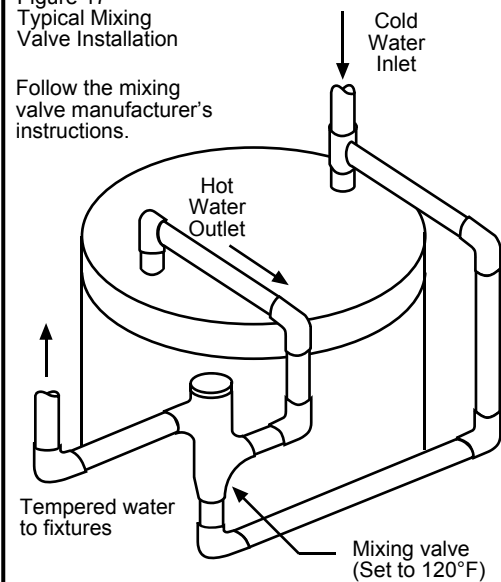

Figure 17
Typical Mixing Valve Installation

Follow the mixing valve manufacturer's instructions.



Please note the following:

- The system should be installed only with piping that is suitable for potable (drinkable) water such as copper, CPVC, or polybutylene. This water heater must not be installed using iron piping or PVC water piping.
- Use only pumps, valves, or fittings that are compatible with potable water.
- Use only full flow ball or gate valves. The use of valves that may cause excessive restriction to water flow is not recommended.
- Use only 95/5 tin-antimony or other equivalent solder. Any lead based solder must not be used.
- Piping that has been treated with chromates, boiler seal, or other chemicals must not be used.
- Chemicals that may contaminate the potable water supply must not be added to the piping system.
- This water heater is suitable for combination water (potable) heating and space heating and not suitable for space heating applications only.

Closed System/Thermal Expansion

! WARNING



Explosion Hazard

If the temperature and pressure relief valve is dripping or leaking, have a qualified person replace it.

Examples of a qualified person include: licensed plumbers, authorized gas company personnel, and authorized service personnel.

Do not plug valve.

Do not remove valve.

Failure to follow these instructions can result in death, or explosion.

As water is heated, it expands (thermal expansion). In a closed system, the volume of water will grow. As the volume of water grows, there will be a corresponding increase in water pressure due to thermal expansion. Thermal expansion can cause premature tank failure (leakage). This type of failure is not covered under the limited warranty. Thermal expansion can also cause intermittent temperature-pressure relief valve operation: water discharged from the valve due to excessive pressure build up. The temperature-pressure relief valve is not intended for the constant relief of thermal expansion. This condition is not covered under the limited warranty.

A properly-sized thermal expansion tank should be installed on all closed systems to control the effects of thermal expansion. Contact a plumbing service agency or your retail supplier regarding the installation of a thermal expansion tank.

Temperature and Pressure Relief Valve

⚠️ WARNING



Explosion Hazard

If the temperature and pressure relief valve is dripping or leaking, have a qualified person replace it.

Examples of a qualified person include: licensed plumbers, authorized gas company personnel, and authorized service personnel.

Do not plug valve.

Do not remove valve.

Failure to follow these instructions can result in death, or explosion.

Figure 18
Temperature and Pressure Relief Valve Installation

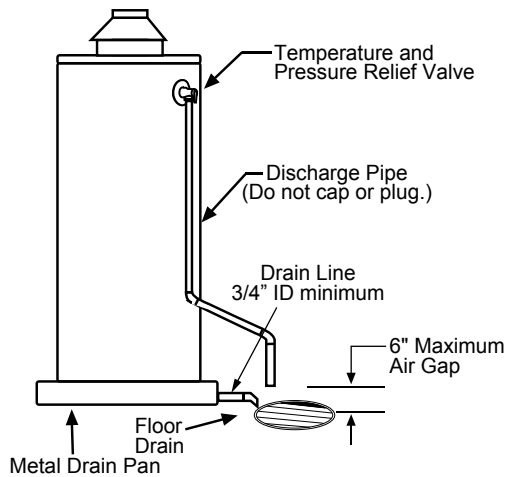

For protection against excessive pressures and temperatures, a temperature and pressure relief valve must be installed in the opening marked "T & P RELIEF VALVE" (see Figure 18). This valve must be design certified by a nationally recognized testing laboratory that maintains periodic inspection of the production of listed equipment or materials as meeting the requirements for Relief Valves and Automatic Shut-off Devices for Hot Water Supply Systems, ANSI Z21.22. The function of the temperature and pressure relief valve is to discharge water in large quantities in the event of excessive temperature or pressure developing in the water heater. The valve's relief pressure must not exceed the working pressure of the water heater as stated on the data plate.

IMPORTANT: Only a new temperature and pressure relief valve should be used with your water heater. Do not use an old or existing valve as it may be damaged or not adequate for the working pressure of the new water heater. Do not place any valve between the relief valve and the tank.

The Temperature & Pressure Relief Valve:

- Must not be in contact with any electrical part.
- Must be connected to an adequate discharge line.
- Must not be rated higher than the working pressure shown on the data plate of the water heater.

The Discharge Line:

- Must not be smaller than the pipe size of the relief valve or have any reducing coupling installed in the discharge line.
- Must not be capped, blocked, plugged or contain any valve between the relief valve and the end of the discharge line.
- Must terminate a maximum of six inches above a floor drain or external to the building. In cold climates, it is recommended that the discharge pipe be terminated at an adequate drain inside the building.
- Must be capable of withstanding 250°F (121°C) without distortion.
- Must be installed to allow complete drainage of both the valve and discharge line.

T&P Relief Valve and Pipe Insulation (Some Models)

1. Locate the temperature and pressure relief valve on the water heater (also known as a T&P relief valve). See Figure 18.
2. Locate the slit running the length of the T&P relief valve insulation.
3. Spread the slit open and fit the insulation over the T&P relief valve. See Figure 19. Apply gentle pressure to the insulation to ensure that it is fully seated on the T&P Relief Valve. Once seated, secure the insulation with duct tape, electrical tape, or equivalent. **IMPORTANT:** The insulation or tape should not block or cover the T&P relief valve drain opening. Also, the insulation or tape should not block or hinder access to the manual relief lever (Figure 19). Ensure that a discharge pipe is installed into the T&P valve discharge opening per the instructions in this manual.
4. Locate the hot water (outlet) & cold water (inlet) pipes to the water heater.
5. Locate the slit running the length of a section of pipe insulation.
6. Spread the slit open and slip the insulation over the cold water (inlet) pipe. Apply gentle pressure along the length of the insulation to ensure that it is fully seated around the pipe. Also, ensure that the base of the insulation is flush with the water heater. Once seated, secure the insulation with duct tape, electrical tape, or equivalent.
7. Repeat steps 5 and 6 for the hot water (outlet) pipe.
8. Add additional sections of pipe insulation as needed.

Figure 19
T&P Relief Valve Insulation

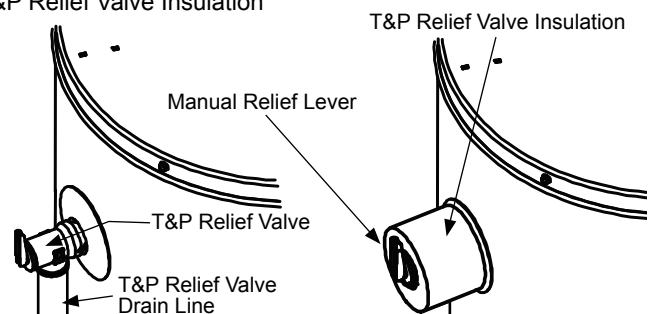

Special Applications

Combination Space Heating/Potable Water System

Some water heater models are equipped with inlet/outlet connections for use in space heating applications.

Note: this water heater, "Suitable for combination water (potable) heating and space heating and not suitable for space heating applications only." If this water heater is to be used to supply both space heating and potable (drinking water), the instructions listed below must be followed.

- Be sure to follow the manual(s) shipped with the air handler system.
- This water heater is not to be used as a replacement for an existing boiler installation.
- Do not use with piping that has been treated with chromates, boiler seal or other chemicals and do not add any chemicals to the water heater piping.
- If the space heating system requires water temperatures in excess of 120°F, a mixing valve or an anti-scald device should be installed per its manufacturer's instructions in the domestic (potable) hot water supply to limit the risk of scald injury.
- Pumps, valves, piping and fittings must be compatible with potable water.
- A properly installed flow control valve is required to prevent thermosiphoning. Thermosiphoning is the result of a continuous flow of water through the air handler circuit during the off cycle. Weeping (blow off) of the temperature and pressure relief valve (T & P) or higher than normal water temperatures are the first signs of thermosiphoning.
- The domestic hot water line from the water heater should be vertical past any mixing valve or supply line to the air handler to remove air bubbles from the system. Otherwise, these bubbles will be trapped in the air handler heat exchanger coil, reducing the efficiency.
- Do not connect the water heater to any system or components previously used with non-potable water heating appliances when used to supply potable water.

Some jurisdictions may require a backflow preventer in the incoming cold water line. This may cause the temperature and pressure relief valve on the water heater to discharge or weep due to expansion of the heated water. A diaphragm-type expansion tank suitable for potable water will normally eliminate this weeping condition. Please read and follow the manufacturer's instructions for the installation of such tanks.

Also see "Water System Piping" section for additional instructions on the proper installation and operation of this water heater.

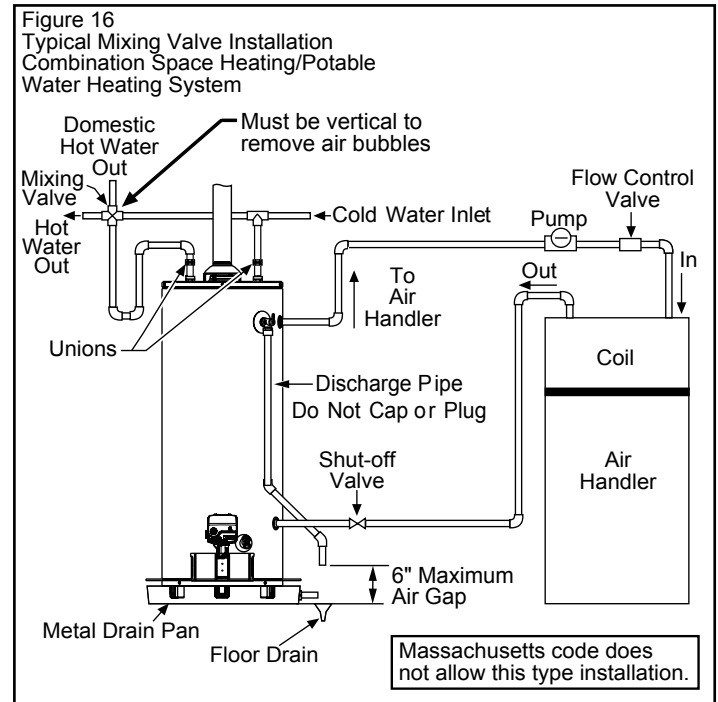

Solar Installation

If this water heater is used as a solar storage heater or as a backup for the solar system, the water supply temperatures to the water heater tank may be in excess of 120°F. A mixing valve or other temperature limiting valve must be installed in the water supply line to limit the supply temperature to 120°F. The unit must be set to Standard Mode (See Operating the Temperature Control System section).

NOTE: Solar water heating systems can often supply water with temperatures exceeding 180°F and may result in water heater malfunction.

Important Information About This Water Heater

This gas water heater was manufactured to voluntary safety standards to reduce the likelihood of a flammable vapor ignition incident. The new technology used in meeting these standards makes this product more sensitive to installation errors. Please review the following checklist and make any required installation upgrades or changes.

Questions? Call 1-877-817-6750.

Installation Checklist

Water Heater Location

Water heater location is important and can affect system performance. Please check the following:

- Installation area free of corrosive elements and flammable materials.
- Centrally located with the water piping system. Located as close to the gas piping and vent pipe system as possible.
- Water heater must be located within 6 feet of 120VAC outlet.
- Located indoors and in a vertical position. Protected from freezing temperatures.
- Proper clearances from combustible surfaces maintained and not installed directly on a carpeted floor.
- Provisions made to protect the area from water damage. Metal drain pan installed and piped to an adequate drain.
- Sufficient room to service the water heater. See "Clearances and Accessibility" section of this manual.
- Water heater not located near an air moving device.
- Is the installed environment dirty (excessive amounts of lint, dirt, dust, etc.)? If so, the flame arrester located on the bottom of the water heater will need to be cleaned periodically. Refer to the "Maintenance of your Water Heater" section of this manual for information on cleaning the flame-trap.

Combustion Air Supply and Ventilation

Check for sufficient combustion air supply. Insufficient air for the combustion of gas will result in the flame becoming "lazy", thereby allowing heat to build up in the combustion chamber. This excessive heat will cause a thermal switch on the door assembly to trip. Is the water heater installed in a closet or other small, enclosed space? If so:

- Are there openings for make-up air to enter and exit the room/area?
- Are the openings of sufficient size? Remember, if there are other gas-fired or air-consuming appliances in the same room, you need more make-up air. Refer to the "Location Requirements" section of this water heater manual for specific requirements.

Fresh air not taken from areas that contain negative pressure producing devices such as exhaust fans, fireplaces, etc.

- Is there a furnace/air handler in the same room space as the water heater? If so, has a return air duct system been attached that exits the room? If so, check for leaks on the air duct system. If no air duct system is present, correct immediately by contacting a local Heating, Ventilation, Air-Conditioning & Refrigeration (HVAC-R) authorized service provider.

- Fresh air supply free of corrosive elements and flammable vapors.
- Fresh air openings sized correctly with consideration given to the blocking effect of louvers and grilles.
- Ductwork is the same cross-sectional area as the openings.

Vent Pipe System

Check for proper drafting at the water heater draft hood. Refer to the "Checking the Draft" section of this manual for the test procedure. If the procedure shows insufficient draft is present, please check the following.

- Draft hood properly installed.
- Vent connectors securely fastened with screws and supported properly to maintain six inch clearance.
- Vent connector made of approved material and sized correctly.
- Vent pipe system installed according to all local and state codes or, in the absence of local and state codes, the "National Fuel Gas Code", ANSI Z223.1(NFPA 54)-current edition.
- Check the vent system for restrictions/obstructions and check the vent termination height. Refer to the "Air Supply and Ventilation" section of this water heater manual for specific requirements. **NOTE:** This water heater utilizes an automatic flue damper that remains closed when the water heater is not operating. Damper must be in open position when appliance main burner is operating. Do not attempt to manually open/operate the damper. Damage to the flue damper may result.
- Recheck for sufficient combustion air supply.

Water System Piping

- Temperature and pressure relief valve properly installed with a discharge line run to an open drain and protected from freezing.
- All piping properly installed and free of leaks.
- Heater completely filled with water.
- Closed system pressure build-up devices installed.
- Mixing valve (when applicable) installed per manufacturer's instructions (see "Water Temperature Regulation" section).

Gas Supply and Piping

- Gas type is the same as that listed on the water heater data plate.
- Gas line equipped with shut-off valve, union, and sediment trap.
- Adequate pipe size and approved pipe material.
- An approved noncorrosive leak detection solution used to check all connections and fittings for possible gas leaks. Correct any leak found.

TEFLON[®] is a registered trademark of E.I. Du Pont De Nemours and Company.

OPERATING YOUR WATER HEATER

Lighting Instructions

Read and understand these directions thoroughly before attempting to start or re-start the water heater. Make sure the viewport is not missing or damaged. (See Figure 28) Make sure the tank is completely filled with water before turning the power switch on. Check the data plate near the gas control valve/thermostat for the correct gas. Do not use this water heater with any gas other than the one listed on the data plate. If you have any questions or doubts, consult your gas supplier or gas utility company.

WARNING



Explosion Hazard

Replace viewport if glass is missing or damaged.

Failure to do so can result in death, explosion or fire.

FOR YOUR SAFETY READ BEFORE LIGHTING

WARNING: If you do not follow these instructions exactly, a fire or explosion may result causing property damage, personal injury or loss of life.

- A. This appliance is equipped with an ignition device which automatically lights the pilot. Do not try to light the pilot by hand
- B. **BEFORE LIGHTING** smell all around the appliance area for gas. Be sure to smell next to the floor because some gas is heavier than air and will settle on the floor.
WHAT TO DO IF YOU SMELL GAS:
 - Do not try to light any appliance.
 - Do not touch any electrical switch; do not use any phone in your building.
 - Immediately call your gas supplier from a neighbor's phone. Follow the gas supplier's instructions.
 - If you cannot reach your gas supplier, call the fire department.
- C. Use only your hand to turn the gas control temperature knob. Never use tools. If the knob will not move by hand, don't try to repair it, call a qualified service technician. Force or attempted repair may result in a fire or explosion.
- D. Do not use this appliance if any part has been under water. Immediately call a qualified service technician to inspect the appliance. Water heaters subjected to flood conditions or anytime the gas controls, main burner or pilot have been submerged in water require replacement of the entire water heater.
- E. **DO NOT USE THIS APPLIANCE IF THERE HAS BEEN AN IGNITION OF VAPORS.** Immediately call a qualified service technician to inspect the appliance. Water heaters subjected to a flammable vapors ignition will show a discoloration on the air intake grid (bottom of combustion chamber) and require replacement of the entire water heater.

LIGHTING INSTRUCTIONS

1. **STOP!** It is imperative that you read all the safety warnings above on this label.
2. Remove the outer door.
3. Move the ON / OFF switch on the Gas Control Valve/Thermostat to the OFF position.
8. This appliance is equipped with a device that automatically lights the pilot.
DO NOT TRY TO LIGHT THE PILOT BY HAND.
9. When the pilot is lit, the status light should blink a heartbeat (bright, dim, bright, dim, etc). If the status light does not start blinking, repeat steps 3 - 7.

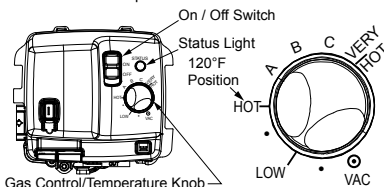

4. To clear any gas that may have accumulated, wait ten (10) minutes. If you then smell gas, **STOP!** Follow "B" in the safety warning above. If you do not smell gas go to the next step.
5. Turn on all electric power to the appliance. (Connect to a grounded 110/120 volt power outlet.)
6. Move the ON / OFF switch on the Gas Control Valve/Thermostat to the ON position.
7. Turn the gas control/temperature knob to the "LOW" temperature setting. As shown above.
10. Set the gas control/temperature knob to the desired setting.
11. Replace the outer door.

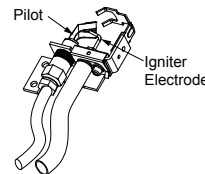

10. Set the gas control/temperature knob to the desired setting.
11. Replace the outer door.

TO TURN OFF GAS TO APPLIANCE

1. Turn off the gas to the water heater at the manual shut-off valve.
2. Move the ON / OFF switch on the Gas Control Valve/Thermostat to the OFF position.
3. Turn off all electric power to the appliance. (Disconnect from a grounded 110/120 volt power outlet.)

L.P.G. (Bottled Propane) Models

Liquefied petroleum gas is over 50% heavier than air and in the occurrence of a leak in the system, the gas will settle at floor level. Basements, crawl spaces, skirted areas under mobile homes (even when ventilated), closets and areas below ground level will serve as pockets for the accumulation of gas. Before lighting an L.P. gas water heater, smell all around the appliance at floor level. If you smell gas, follow the instructions as given in the warning on the front page.

When your L.P. tank runs out of fuel, turn off the gas at all gas appliances including pilot lights. After the tank is refilled, all appliances must be re-lit according to their manufacturer's instructions.

Checking the Draft

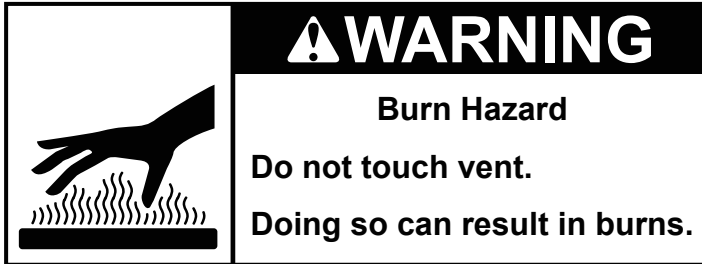

After successfully lighting the water heater, allow the unit to operate for 15 minutes and check the draft hood relief opening for proper draft. Make sure all other appliances in the area are operating and all doors are closed when performing the draft test. Pass a match flame around the relief opening of the draft hood. A steady flame drawn into the opening indicates proper draft. If the flame flutters or is blown out, combustion products are escaping from the relief opening. If this occurs, do not operate the water heater until proper adjustments or repairs are made to the vent pipe system and/or air supply requirements.

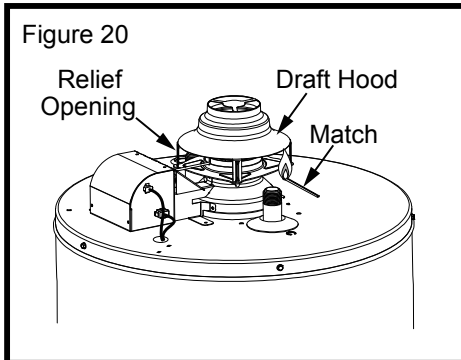

Burner Flames

Inspect the burner flames through the viewport and compare them to the drawings in Figure 21. A properly operating burner should produce a soft blue flame. Blue tips with yellow inner cones are satisfactory. The tips of the flame may have a slight yellow tint. The flame should not be all yellow or have a sharp blue-orange color. Contaminated air may cause an orange colored flame. Contact a qualified person if the flame is not satisfactory.

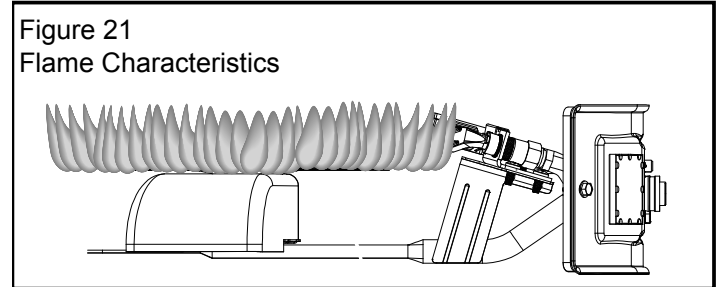

Water Temperature Stacking

Stacking occurs when a series of short draws of hot water (3 gallons or less) are taken from the water heater tank. This causes increased cycling of the burner and can result in increased water temperatures at the hot water outlet.

This water heater's temperature control has been designed to accurately regulate the water temperature. However, under certain operating conditions, the water temperature may temporarily exceed the dial setting. Consequently, in addition to setting the temperature no higher than 120°F, we recommend the installation of a mixing valve or an anti-scald device in the hot water supply line or at the point of use to further reduce the risk of scald injury. These devices can be obtained from a plumbing service agency or your retail supplier.

Emergency Shut Down

IMPORTANT: Should overheating occur or the gas supply fails to shut off, turn off the water heater's manual gas control valve and call a qualified person.

Water Temperature Regulation

⚠️ WARNING

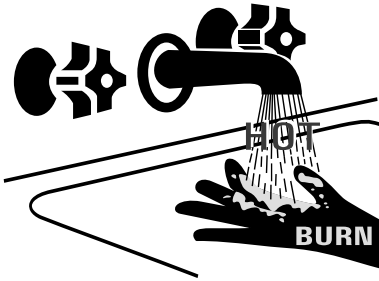

Water temperature over 125°F can cause severe burns instantly or death from scalds.

Children, disabled and elderly are at highest risk of being scalded.

Feel water before bathing or showering.

Temperature limiting valves are available.

The thermostat is adjusted to the pilot position when it is shipped from the factory. Water temperature can be regulated by moving the temperature dial to the preferred setting. The preferred starting point is 120°F at the "HOT" setting. Align the knob with the desired water temperature as shown in Figure 22. There is a hot water scald potential if the thermostat is set too high.

NOTE: Temperatures shown on the gas control valve/thermostat are approximates. The actual temperature of the heated water may vary.

IMPORTANT: Adjusting the thermostat past the 120°F bar on the temperature dial will increase the risk of scald injury. Hot water can produce first degree burns within:

Table 5:

Water Temperature °F	Time for 1st Degree Burn (Less Severe Burns)	Time for Permanent Burns 2nd & 3rd Degree (Most Severe Burns)
110	(normal shower temp.)	
116	(pain threshold)	
116	35 minutes	45 minutes
122	1 minute	5 minutes
131	5 seconds	25 seconds
140	2 seconds	5 seconds
149	1 second	2 seconds
154	instantaneous	1 second

(U.S. Government Memorandum, C.P.S.C., Peter L. Armstrong, Sept. 15, 1978)

Figure 22
Gas Control Valve/Thermostat Settings

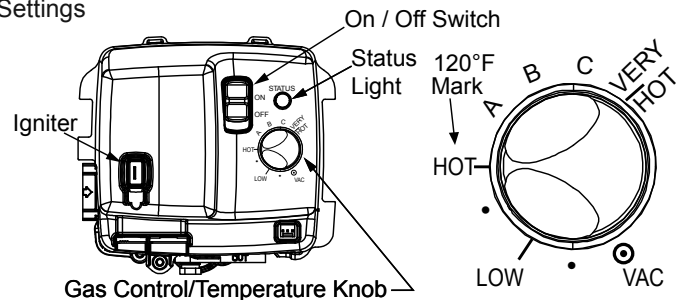

NOTE: During low demand periods when hot water is not being used, a lower thermostat setting will reduce energy losses and may satisfy your normal hot water needs. If hot water use is expected to be more than normal, a higher thermostat setting may be required to meet the increased demand. When leaving your home for extended periods (vacations, etc.), turn the temperature dial to the vacation (VAC) setting. This will maintain the water at low temperatures with minimum energy losses and prevent the tank from freezing during cold weather.

Electrical Connections

Before plugging in the water heater, always make sure:

- The Voltage and frequency correspond to that specified on the water heater.
- The electrical outlet has the proper overload fuse or breaker protection.
- Water heater to be located within 6 feet of 120VAC outlet.
- Unit is to connect to a 120VAC electrical supply outlet (extension cord is not allowed).
- The water heater and the outlet are properly grounded.
- Installed in accordance with prevailing provisions of local codes, or in the absence of such, National Electric Code, ANSI/NFPA 70 current edition.

Completely fill the tank with water and check all connections for leaks. Open the nearest hot water faucet and let it run for three (3) minutes to purge the water lines of air and sediment and to ensure complete filling of the tank. The Electrical power may then be turned on. Verify proper operation after servicing.

⚠ WARNING



Electric Shock Hazard

Disconnect power before servicing.

Replace all parts and panels before operating.

Failure to do so can result in death or electrical shock.

⚠ WARNING



Electric Shock Hazard

Plug into a grounded 3 prong outlet.

Do not remove ground prong.

Do not use an adapter.

Do not use an extension cord.

Failure to follow these instructions can result in death, fire, or electrical shock.

Figure 23:
Wiring Diagram

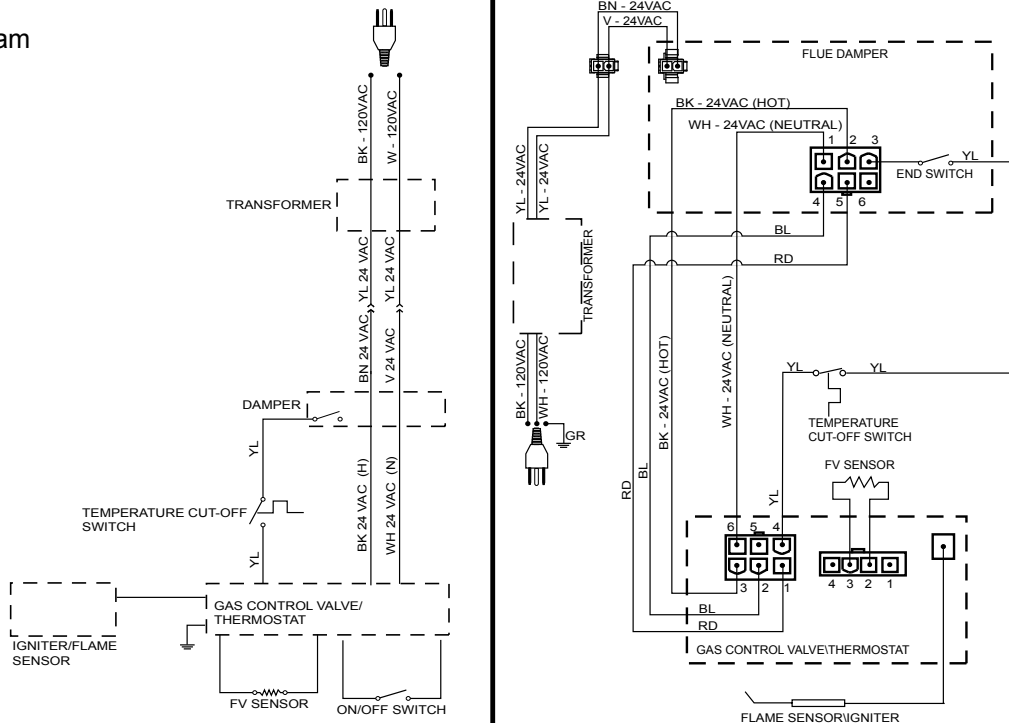

You must provide all wiring of the proper size outside of the water heater. You must obey local codes and electric utility requirements when you install this wiring. This appliance must be electrically grounded in accordance with local codes or, in the absence of local codes, with the National Electrical Code ANSI/NFPA No 70 (current edition) and/or THE CSA C22.1 ELECTRICAL CODE.(CURRENT EDITION)

Note: If any of the original wire as supplied with the appliance must be replaced, it must be replaced with 105°C wire or its equivalent.

Caution: Label all wires prior to disconnection when servicing controls. Wiring errors can cause improper and dangerous operation.

Operating the Temperature Control System

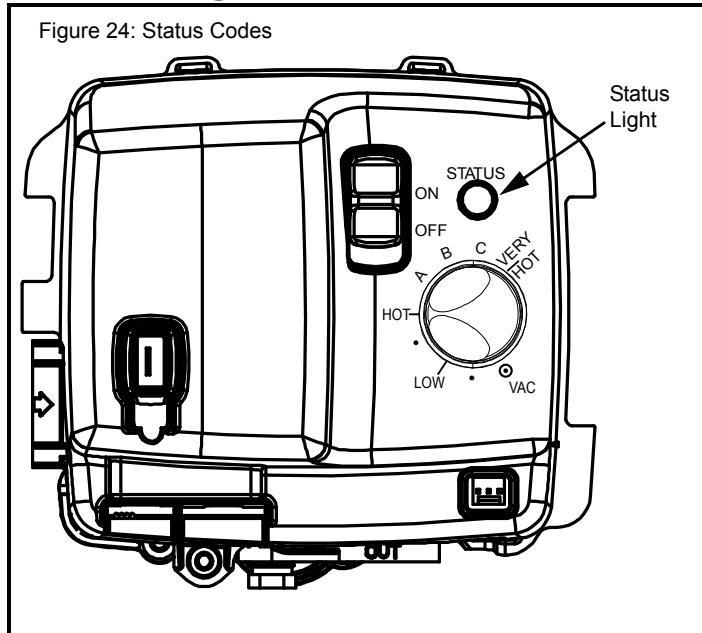

Water Temperature Adjustment

The water temperature setting can be adjusted from 70°F to 160°F. Turn the Gas Control/Temperature Knob to the desired setting/temperature.

Operating Modes and Settings

- **Standard Mode** - The controller adjusts the water heater to maintain the temperature set by the user.
- **Vacation Setting** - The Vacation Setting (VAC) sets the controller at approximately 70°F. This setting is recommended when the water heater is not in use for a long period of time. This effectively turns the controller temperature setting down to a temperature that prevents the water in the water heater from freezing while still conserving energy.

Status Light Code

LED FLASH SEQUENCE	CONTROL STATUS
Short flash once every four second	IDLE (No call for heat, no fault conditions)
"Heartbeat", alternates bright/dim	Call for Heat (No fault conditions)
One Flash, three second pause	Low Flame Signal (control continues to operate)
Two Flash, three second pause	End Switch Failed Closed
Three Flash, three second pause	End Switch Failed Open or TCO Limit Lockout
Four Flash, three second pause	ECO Limit Lockout
Five Flash, three second pause	Flame Out of Sequence
Six-One Flash, three second pause	Soft Lockout - Retry Limit - Failed TFI
Six-Two Flash, three second pause	Soft Lockout - Recycle Limit - Flame Lost - END Switch Fails
Six-Three Flash, three second pause	Soft Lockout - Recycle Limit - Flame Lost
Six-Four Flash, three second pause	Soft Lockout - Flame out of Sequence Sensed
Seven Flash, three second pause	Flammable Vapor Sensor (FVS) Lockout
Eight-One Flash, three second pause	Flammable Vapor Sensor (FVS) Fault Detected
Eight-Two Flash, three second pause	Temperature Sensor Fault Detected
Eight-Three Flash, three second pause	Electronic Fault Detected
Eight-Four Flash, three second pause	Gas Control Valve/Thermostat Fault Detected

Operational Conditions

Condensation

Moisture from the products of combustion condenses on the tank surface and the outside jacket of the water heater and forms drops of water which may fall onto the burner or other hot surfaces. This will produce a “sizzling” or “frying” noise.

NOTE: This condensation is normal and should not be confused with a leaking tank. Condensation may increase or decrease at different times of the year.

High efficient energy saver water heaters will produce larger amounts of condensation on initial start-up or when a large amount of hot water is being used. **NOTE:** Do not confuse this with a “tank leak”. Once the water reaches a temperature of 120°F and the tank warms up (usually 1-2 hours), the condensation will stop.

IMPORTANT: It is always recommended that a suitable metal drain pan be installed under the water heater to protect the area from water damage resulting from normal condensation production, a leaking tank or piping connections. Refer to “Location Requirements” on page 4. Under no circumstances is the manufacturer to be held responsible for any water damage in connection with this water heater.

Water Heater Sounds

During the normal operation of the water heater, sounds or noises may be heard. These noises are common and may result from the following:

1. Normal expansion and contraction of metal parts during periods of heat-up and cool-down.
2. Condensation causes sizzling and popping within the burner area and should be considered normal.
3. Sediment buildup in the tank bottom will create varying amounts of noise and may cause premature tank failure. Drain and flush the tank as directed under “Draining and Flushing”.

Smoke/Odor

The water heater may give off a small amount of smoke and odor during the initial start-up of the unit. This is due to the burning off of oil from metal parts of a new unit and will disappear after a few minutes of operation.

Safety Shut-off

This water heater is designed to automatically shut-off in the event of the following:

1. The water temperature exceeds 189°F (87°C) for 160°F models.
3. Excessive combustion chamber temperatures.
4. The presence of flammable vapors.

This unit is equipped with a flammable vapor sensor, designed to shut off the gas supply in the event the heater has been exposed to flammable vapors (spilled gasoline or paint fumes for example). **IMPORTANT:** If the flammable vapor sensor activates a qualified service person must be contacted to reset the water heater. This unit is also equipped with a thermal switch designed to shut off the gas control valve/thermostat in the event the water heater has poor combustion caused by a blocked vent or insufficient combustion air. If the switch opens, check the flame-trap for signs of high temperature (blue or black discoloration), and inspect your installation for any problems with venting or combustion air (See Troubleshooting Flowchart on page 29). Reset the thermal switch by depressing the small button in the center of the switch.

IMPORTANT: Correct any issues prior to resetting the switch. Contact the Product Service and Support Department for service information at: 1-877-817-6750.

A temperature limit switch or ECO (Energy Cut Off) sensor located in the gas control valve/thermostat, is used to shut off the water heater if the water temperature exceeds 189°F (87°C).

The Diagnostic Status Light will flash a code indicating an “Overheat Failure” (4 Flashes). See “Operating the Temperature Control System.” If the gas control valve/thermostat has an “ECO Lockout” the gas control valve/thermostat must be replaced by a qualified person. Contact your local dealer for service information.

Anode Rod/Water Odor

Each water heater contains at least one anode rod, which will slowly deplete (due to electrolysis) prolonging the life of the water heater by protecting the glass-lined tank from corrosion. Adverse water quality, hotter water temperatures, high hot water usage, hydronic heating devices, and water softening methods can increase the rate of anode rod depletion. Once the anode rod is depleted, the tank will start to corrode, eventually developing a leak.

Certain water conditions will cause a reaction between the anode rod and the water. The most common complaint associated with the anode rod is a “rotten egg smell” produced from the presence of hydrogen sulfide gas dissolved in the water.

IMPORTANT: Do not remove this rod permanently as it will void any warranties. A special anode rod may be available if water odor or discoloration occurs.

NOTE: This rod may reduce but not eliminate water odor problems. The water supply system may require special filtration equipment from a water conditioning company to successfully eliminate all water odor problems.

Artificially softened water is exceedingly corrosive because the process substitutes sodium ions for magnesium and calcium ions. The use of a water softener may decrease the life of the water heater tank.

The anode rod should be inspected after a maximum of three years and annually thereafter until the condition of the anode rod dictates its replacement.

NOTE: Artificially softened water requires the anode rod to be inspected annually.

The following are typical (but not all) signs of a depleted anode rod:

- The majority of the rods diameter is less than 3/8”.
- Significant sections of the support wire (approx. 1/3 or more of the anode rod’s length) are visible.

If the anode rod show signs of either or both it should be replaced. **NOTE:** Whether re-installing or replacing the anode rod, check for any leaks and immediately correct if found.

In replacing the anode:

1. Turn off gas supply to the water heater.
2. Shut off the water supply and open a nearby hot water faucet to depressurize the water tank.
3. Drain approximately 5 gallons of water from tank. (Refer to “Draining and Flushing” for proper procedures). Close drain valve.
4. Remove old anode rod.
5. Use Teflon® tape or approved pipe sealant on threads and install new anode rod.
6. Turn on water supply and open a nearby hot water faucet to purge air from water system.
7. Check for any leaks and immediately correct any if found.
8. Restart the water heater as directed in this manual. See the Repair Parts Illustration for anode rod location.

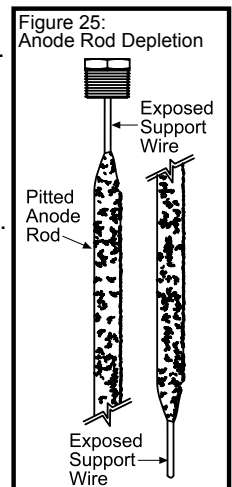

TEFLON® is a registered trademark of E.I. Du Pont De Nemours and Company.

MAINTENANCE OF YOUR WATER HEATER

Draining and Flushing

It is recommended that the tank be drained and flushed every 6 months to remove sediment which may build up during operation. The water heater should be drained if being shut down during freezing temperatures. To drain the tank, perform the following steps:

1. Turn off the gas to the water heater at the manual gas shut-off valve.
1. Move the switch on the gas control valve/thermostat to the "OFF" position to turn off the water heater.
2. Open a nearby hot water faucet until the water is no longer hot.
3. Close the cold water inlet valve.
4. Connect a hose to the drain valve and terminate it to an adequate drain or external to the building.
5. Open the water heater drain valve and allow all of the water to drain from the tank. Flush the tank with water as needed to remove sediment.
6. Close the drain valve, refill the tank, and restart the heater as directed in this manual.

If the water heater is going to be shut down for an extended period, the drain valve should be left open.

IMPORTANT: Condensation may occur when refilling the tank and should not be confused with a tank leak.

Routine Preventative Maintenance

At least annually, a visual inspection should be made of the venting and air supply system, piping systems, main burner, pilot burner, and Flame-trap. Check the water heater for the following:

- Obstructions, damage, or deterioration in the venting system. Make sure the ventilation and combustion air supplies are not obstructed.
- Build up of soot and carbon on the main burner and pilot burner. Check for a soft blue flame.
- Leaking or damaged water and gas piping.
- Presence of flammable or corrosive materials in the installation area.
- Presence of combustible materials near the water heater.
- After servicing this water heater, check to make sure it is working properly. (See Operating Your Water Heater section of this manual.)

IMPORTANT: If you lack the necessary skills required to properly perform this visual inspection, you should not proceed, but get help from a qualified person.

Temperature and Pressure Relief Valve

⚠ WARNING



Explosion Hazard

If the temperature and pressure relief valve is dripping or leaking, have a qualified person replace it.

Examples of a qualified person include: licensed plumbers, authorized gas company personnel, and authorized service personnel.

Do not plug valve.

Do not remove valve.

Failure to follow these instructions can result in death, or explosion.

Manually operate the temperature and pressure relief valve at least once a year to make sure it is working properly. To prevent water damage, the valve must be properly connected to a discharge line which terminates at an adequate

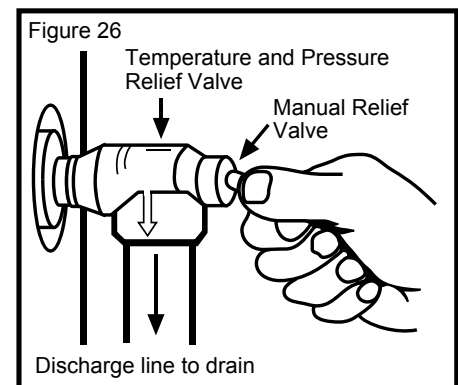

drain. Standing clear of the outlet (discharged water may be hot), slowly lift and release the lever handle on the temperature and pressure relief valve to allow the valve to operate freely and return to its closed position. If the valve fails to completely reset and continues to release water, immediately shut off the manual gas control valve and the cold water inlet valve and call a qualified person.

Replacement Parts

IMPORTANT: The following maintenance procedures are for the Flame Guard™ Safety System components and should be performed by a qualified person.

Replacement parts may be ordered through your plumber or the local distributor. Parts will be shipped at prevailing prices and billed accordingly. When ordering replacement parts, always have the following information ready:

1. model, serial, and product number
2. type of gas
3. item number
4. parts description

See pages 31-32 for a list of available repair parts.

Removing the Manifold Assembly

1. Turn off the gas to the water heater at the manual shut-off valve (Figure 5).
2. Move the ON/OFF switch on the gas control valve/thermostat to the "OFF" position to turn off the water heater. (Figure 22).

3. Remove the outer door.
4. Remove the two screws (1/4" nut driver) securing the manifold door assembly to the combustion chamber (Figure 28).

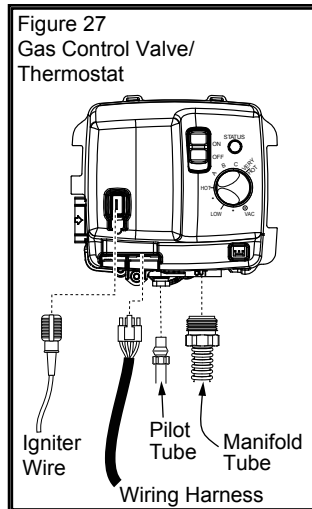

5. Disconnect the pilot tube (7/16" wrench), the igniter wire, and manifold tube (3/4" wrench) at the gas control valve/thermostat. Also use needle nose pliers to disconnect the yellow TCO wire leads from the thermal switch on the manifold door. **NOTE:** L.P. Gas systems use reverse (left-hand) threads on the manifold tube.

6. Grasp the manifold tube and push down slightly to free the manifold and pilot tube.
7. Carefully remove the manifold assembly from the burner compartment.

NOTE: Be sure not to damage internal parts.

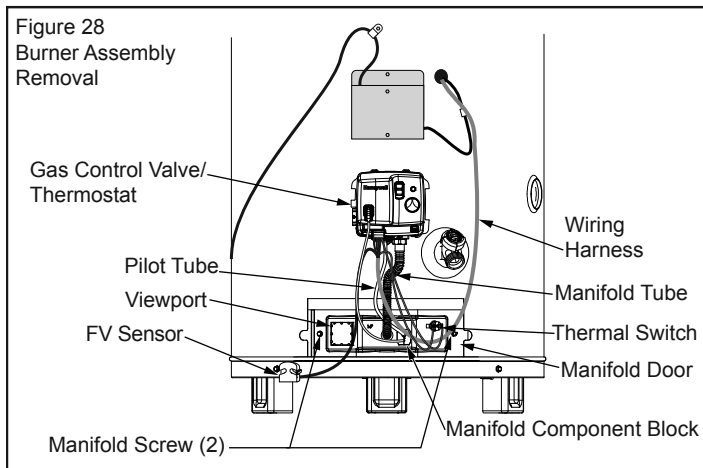

Removing the Burner from the Manifold Assembly

Natural Gas Burner (Low Nox) & L.P. Burner

1. Take off the burner by removing the two (2) screws located underneath the burner.
2. Check the burner to see if it is dirty or clogged. The burner may be cleaned with soap and hot water (Figure 29).

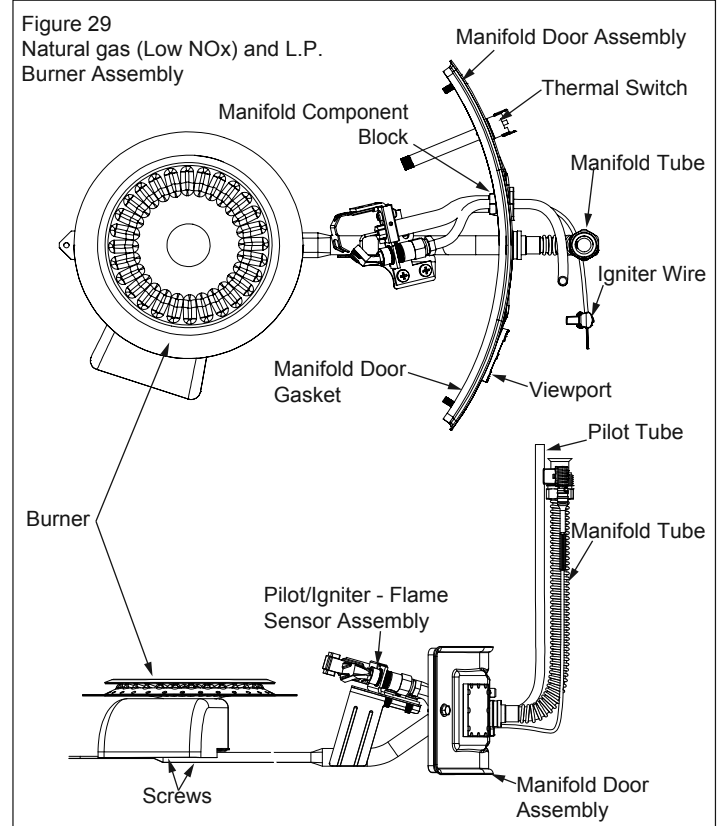

Replacing the Pilot/Igniter - Flame Sensor Assembly

1. Remove the manifold assembly as directed previously.
2. Lift the retainer clip straight up from the back of the manifold component block (using a flat-blade screwdriver), then remove the manifold component block from the manifold door (Figure 30).

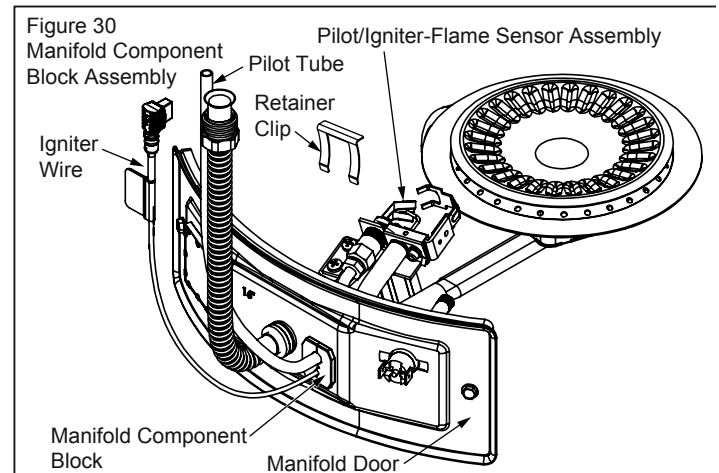

3. Using a 7/16" wrench, loosen the nut securing the pilot tube to the pilot assembly.

NOTE: To prevent any bending of the pilot bracket, use pliers to hold the pilot assembly bracket while loosening the pilot nut.

4. Pull the pilot tube from the pilot assembly (Figure 31).

IMPORTANT: Be careful not to bend or alter the position of the pilot assembly components.

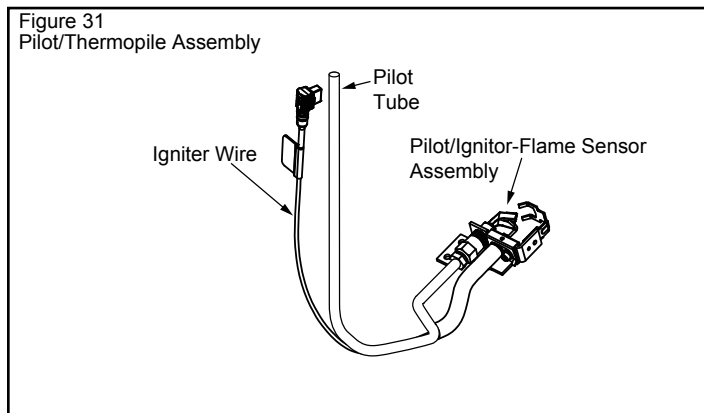

5. Use a screwdriver to remove the screws securing the Pilot/Ignitor - Flame Sensor Assembly. Keep the screws for reattachment.
6. Using the old pilot/pilot tube assembly as a guide, bend the new pilot tube to match the old one. Make only the bends closest to the pilot before going to the next step.
7. Push the new pilot tube and igniter wire through the hole in the manifold door (See Figure 30). Reconnect the pilot tube and tighten the nut securing it to the pilot assembly. **IMPORTANT:** Keep the pilot orifice in the pilot when making the connection. DO NOT operate the water heater without the pilot orifice installed. Reattach the pilot assembly to the manifold.
8. Be sure the igniter wire is positioned through the bottom opening of the manifold component block. See "Replacing Manifold Assembly" section.

Filter Installation and Cleaning

IMPORTANT: It is essential that the filter be installed properly. If you encounter difficulty installing the filter or have a question, please call the Service & Warranty Department at 1-877-817-6750.

Failure to install (and clean) the air filter assembly properly can allow dust and lint to restrict the air supply to the water heater. If that occurs, the pilot light could go out or the thermal switch could shut the water heater off. A service call could be needed to clean the flame trap. These conditions are not defects and are not covered by the warranty.

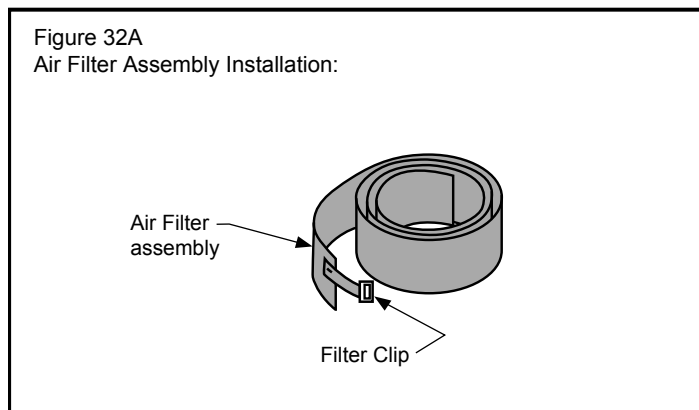

Install the air filter assembly as described below and clean as needed. Replace the air filter assembly with a new one if it is damaged.

1. Before installing the air filter assembly, remove any dust, lint or debris (including any packaging materials or tape) from under the water heater. For existing installations, a visual inspection of the flame-trap is recommended. Refer to "External Inspection & Cleaning of the Flame-trap."
2. Wrap the filter around the base of the water heater. Cut to fit around a sensor if present. Trim excess filter material with scissors but allow filter material to overlap a few inches (Figure 32B).
3. The filter should fit snugly against the base of the water heater with no gaps. The filter must fit flush against the bottom of the drain pan and/or floor. Hold the filter in place, then stretch the filter clip over the overlapped joint and hook in place (Figure 32B).
4. Check the filter at least every three months and clean as necessary. After installation, the filter may be cleaned by using a vacuum cleaner with a brush attachment to remove lint and dust. **NOTE:** Because the amount of dust and lint in the air can vary, your filter may need to be inspected/ cleaned more often. In some instances, the filter may need to be removed and washed using mild hand soap and water to remove any oily residue. After washing, allow to dry and properly reinstall.

Never operate the water heater without a clean air filter.

Figure 32B
Installing Air Filter Assembly:

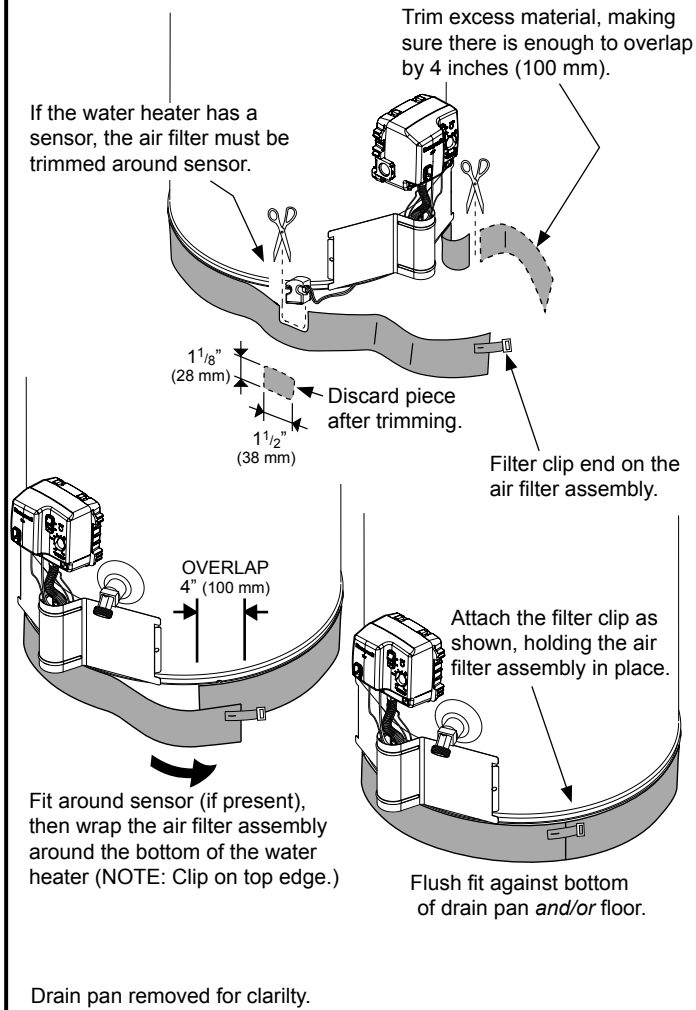

External Inspection & Cleaning of the Flame-trap

Although not likely to occur, if debris collects on the flame-trap, use a vacuum, compressed air, or a soft bristle brush to remove it.

NOTE: If unable to inspect or clean the flame trap from underneath, follow the "Cleaning the Combustion Chamber and Flame-trap" section instructions.

Figure 33A
Flame-trap visual inspection

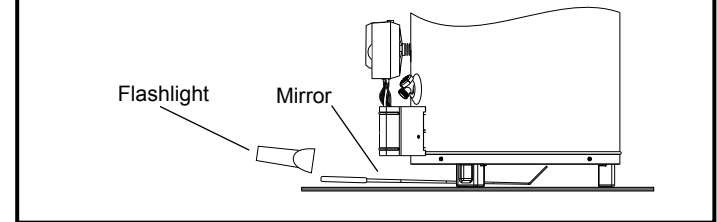

Cleaning the Combustion Chamber and Flame-trap

1. Follow procedure outlined in "Removing the Manifold Assembly".
2. Use a vacuum cleaner/shop vac to remove all loose debris in the combustion chamber (Figure 33B). Use compressed air to clear any dust or debris that may have accumulated in the flame-trap.
3. Reassemble following the procedure under "Replacing the Manifold Assembly".

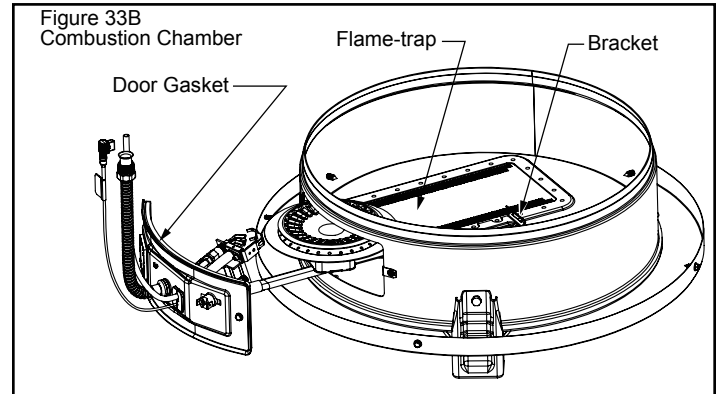

Replacing the Manifold Assembly

⚠ WARNING



Explosion Hazard

Tighten both manifold door screws securely.

Remove any fiberglass between gasket and combustion chamber.

Replace viewport if glass is missing or damaged.

Replace two piece wire connector if missing or removed.

Replace door gasket if damaged.

Failure to follow these instructions can result in death, explosion, or fire.

1. Check the door gasket for damage or imbedded debris prior to installation.
2. Inspect the viewport for damage and replace as required.
3. Insert the manifold assembly into the burner compartment making sure that the tab of the manifold tube engages in the slot of the bracket inside the combustion chamber (Figure 34).
4. Inspect the door gasket and make sure there is no fiberglass insulation between the gasket and the combustion chamber.
5. Replace the two screws which secure the manifold assembly door to the combustion chamber and tighten securely. There should be no space between the gasket part of the manifold door and combustion chamber. **IMPORTANT:** Do not operate the water heater if the door gasket does not create a seal between the manifold door and the combustion chamber.
6. Reconnect the yellow wire leads to the thermal switch (Figure 27), the manifold tubing (3/4" wrench) and pilot tubing (7/16" wrench), to the gas control valve/thermostat. Do not cross-thread or apply any thread sealant to the fittings.
NOTE: L.P. Gas systems use reverse (left-hand) threads on the manifold tube.

7. If replacing the pilot tube, install ferrule nut supplied with kit into the gas valve at the pilot tube location, hand tight only. Insert pilot tube into ferrule nut until tube bottoms out then tighten nut with a 7/16" wrench until crimp connection seals to pilot tube. Continue to tighten until the nut is tight in gas valve.
8. Reconnect the igniter wire to the gas control valve/thermostat.
9. Turn the gas supply on and check for leaks. Test the water heater by brushing on an approved noncorrosive leak detection solution. Bubbles forming indicate a leak. Correct any leak found.
10. Refer to the "Lighting Instructions" on page 16. With the burner lit, check the gas control valve/thermostat supply line, manifold component block, manifold tube, and pilot tube connections for leaks. Check for leaks by brushing on an approved noncorrosive leak detection solution. Bubbles forming indicate a leak. Correct any leak found. **IMPORTANT:** All leaks must be fixed immediately
11. Replace the outer door.

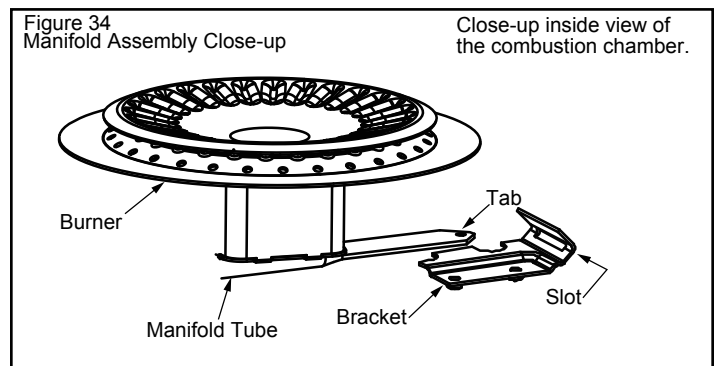

Igniter System

The STP (Spark to Pilot) igniter system consists of the pilot, electrode, and wire. The pilot is ignited by an electric spark generated when the gas control valve/thermostat sends an electrical signal to the electrode. Use only factory authorized STP igniter parts for replacement.

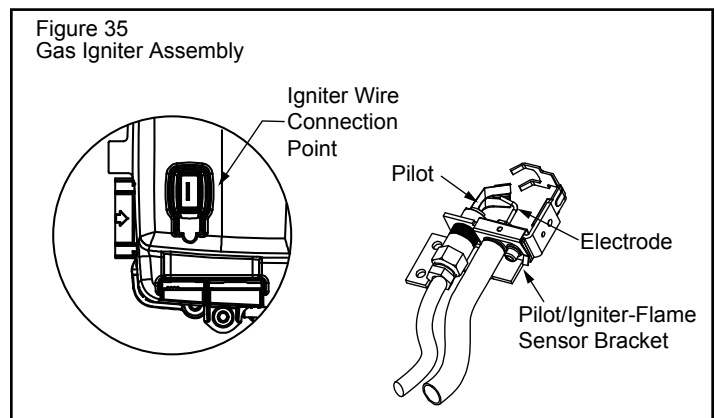

Removing and Replacing the Gas Control Valve/Thermostat

IMPORTANT: The gas control valve/thermostat is a standard valve with wire leads that connect to a thermal switch, flue damper, igniter, and flammable vapor sensor

Removing the Gas Control Valve/Thermostat:

1. Turn off the gas at the manual shut-off valve on the gas supply pipe (Figure 5).
2. Move the ON/OFF switch on the gas control valve/thermostat to the "OFF" position to turn off the water heater and unplug from the wall outlet. (Figure 22).
3. Drain the water heater. Refer to the section of "Draining and Flushing" and follow the procedure.
4. Disconnect the wire harness, flammable vapor sensor wires, and igniter wire from the gas control valve/thermostat. Disconnect pilot tube (7/16" wrench) and manifold tube (3/4" wrench) at the gas control valve/thermostat (Figure 27). **NOTE:** L.P. Gas systems use reverse (left-hand) threads on the manifold tube.
5. Refer to "Gas Piping" (Figure 5) and disconnect the ground joint union in the gas piping. Disconnect the remaining pipe from the gas control valve/thermostat.
6. To remove the gas control valve/thermostat, thread a 4" section of gas pipe into the inlet and use it to turn the gas control valve/thermostat (counterclockwise.) Do not use pipe wrench or equivalent to grip body. Damage may result, causing leaks. Do not insert any sharp

objects into the inlet or outlet connections. Damage to the gas control valve/thermostat may result.

Gas Control Valve/Thermostat:

To replace the gas control valve/thermostat, reassemble in reverse order. When replacing the gas control valve/thermostat, thread a 4" section of gas pipe into the inlet and use it to turn the gas control valve/thermostat (clockwise.) **DO NOT OVER TIGHTEN**, damage may result.

- Be sure to use approved Teflon® tape or pipe joint compound on the gas piping connections and fitting on the back of the gas control valve that screws into tank.
- Be sure to remove the pilot ferrule nut from the new gas control valve/thermostat.
- Turn the gas supply on and check for leaks. Test the water heater by brushing on an approved noncorrosive leak detection solution. Bubbles forming indicate a leak. Correct any leak found.
- Be sure tank is completely filled with water before lighting and activating the water heater. Follow the "Lighting Instructions" on page 16.
- With the burner lit, check the gas control valve/thermostat supply line, manifold component block, manifold tube, and pilot tube connections for leaks. Check for leaks by brushing on an approved noncorrosive leak detection solution. Bubbles forming indicate a leak. Correct any leak found. **IMPORTANT:** All leaks must be fixed immediately
- If additional information is required, contact the Service Department at: 1-877-817-6750.

Flame Guard™ Safety System Operational Checklist

1. Manifold gasket properly sealed.
2. Viewport not damaged or cracked.
3. Flame-trap free of debris and undamaged.
4. Manifold component block properly installed.
5. No leaks at pilot and manifold connection.
6. Manifold door screws securely tightened.
7. Depress the button on the thermal switch.

TROUBLESHOOTING CHART

PROBLEM	POSSIBLE CAUSE(S)	CORRECTIVE ACTION
BURNER WILL NOT IGNITE	<ol style="list-style-type: none"> 1. Pilot will not light 2. Thermostat set too low 3. No gas 4. Dirt in the gas lines 5. Pilot line clogged 6. Main burner line clogged 7. Non-functioning gas control valve/thermostat 8. Heater installed in a confined area 9. Flue Damper not functioning 	<ol style="list-style-type: none"> 1. See PILOT WILL NOT LIGHT OR REMAIN LIT 2. Turn temp. dial to desired temperature 3. Check with gas utility company 4. Notify utility-install trap in gas line 5. Clean, locate source and correct 6. Clean, locate source and correct 7. Replace gas control valve/thermostat 8. Provide fresh air ventilation 9. Cycle power to the water heater off and on. If problem persists replace the flue damper
PILOT WILL NOT LIGHT OR REMAIN LIT	<ol style="list-style-type: none"> 1. Non-functioning Pilot/Igniter-Flame Sensor 2. The thermal switch tripped 3. Igniter wire connection loose 4. Air in gas line 5. Low gas pressure 6. No gas 7. Dirt in gas lines 8. Cold drafts 9. Thermostat ECO switch open 10. Pilot line or orifice clogged 11. Air for combustion obstructed 12. FV Sensor Lockout 13. Flue Damper not functioning 	<ol style="list-style-type: none"> 1. See Status Light Code Troubleshooting Table section 2. See Pilot Light Troubleshooting Flowchart section 3. Seat connector firmly in socket 4. Bleed the air from the gas line 5. Check with gas utility company 6. Check with gas utility company 7. Notify utility-install dirt trap in gas line 8. Locate source and correct 9. Replace thermostat 10. Clean, locate source and correct 11. See maintenance section for inspection and cleaning of flame trap. 12. Contact a qualified person to reset the sensor 13. Cycle power to the water heater off and on. If problem persists replace the flue damper

PROBLEM	POSSIBLE CAUSE(S)	CORRECTIVE ACTION
BURNER FLAME YELLOW-LAZY	<ol style="list-style-type: none"> Insufficient secondary air Low gas pressure Flue clogged Flue damper partially open Main burner line clogged Heater installed in a confined area Obstruction in main burner orifice 	<ol style="list-style-type: none"> Provide ventilation to water heater Check with gas utility company Clean, locate source and correct Cycle gas control valve/thermostat OFF then ON. If problem persists replace damper Clean, locate source and correct Proper fresh air ventilation Clean or replace orifice
HIGH OPERATION COSTS	<ol style="list-style-type: none"> Thermostat set too high Sediment or lime in tank Water heater too small for job Wrong piping connections Leaking faucets Gas leaks Wasted hot water Long runs of exposed piping Hot water piping in exposed wall Flue Damper seal not functioning 	<ol style="list-style-type: none"> Set temperature dial to lower setting Drain/flush-provide water treatment if needed Install adequate heater Correct piping-dip tube must be in cold inlet Repair faucets Check with utility-repair at once Advise customer Insulate piping Insulate piping Replace the flue damper
INSUFFICIENT HOT WATER	<ol style="list-style-type: none"> Thermostat set too low Sediment or lime in tank Water heater too small Wrong piping connections Leaking faucets Wasted hot water Long runs of exposed piping Hot water piping in outside wall Low gas pressure 	<ol style="list-style-type: none"> Turn temperature dial to desired setting Drain/flush-provide water treatment if needed Install adequate heater Correct piping-dip tube must be in cold inlet Repair faucets Advise customer Insulate piping Insulate piping Check with gas utility company
SLOW HOT WATER RECOVERY	<ol style="list-style-type: none"> Insufficient secondary air Flue clogged Low gas pressure Improper calibration Water heater too small Wrong piping connections Wasted hot water 	<ol style="list-style-type: none"> Provide ventilation to water heater. Check flue way, flue baffle, and burner Clean flue, locate source and correct Check with gas utility company Replace thermostat Install adequate heater Correct piping-dip tube must be in cold inlet Advise customer
DRIP FROM RELIEF VALVE	<ol style="list-style-type: none"> Excessive water pressure Heater stacking Closed water system 	<ol style="list-style-type: none"> Use a pressure reducing valve and relief valve Lower the thermostat setting See "Closed System/Thermal Expansion"
THERMOSTAT FAILS TO SHUT-OFF	<ol style="list-style-type: none"> Thermostat not functioning properly Improper calibration 	<ol style="list-style-type: none"> Replace thermostat Replace thermostat
COMBUSTION ODORS	<ol style="list-style-type: none"> Insufficient secondary air Flue clogged Heater installed in a confined area 	<ol style="list-style-type: none"> Provide ventilation to water heater. Check flue way, flue baffle, and burner Clean, locate source and correct Provide fresh air ventilation
SMOKING AND CARBON FORMATION (SOOTING)	<ol style="list-style-type: none"> Insufficient secondary air Low gas pressure Flue clogged Thermostat not functioning properly Heater installed in a confined area Burner flame yellow-lazy 	<ol style="list-style-type: none"> Provide ventilation to water heater. Check flue way, flue baffle, burner Check with gas utility company Clean, locate source and correct Replace thermostat Provide fresh air ventilation See "Burner Flame Yellow-Lazy"
CONDENSATION	<ol style="list-style-type: none"> Temperature setting too low 	<ol style="list-style-type: none"> Increase the temperature setting
BURNER FLAME FLOATS AND LIFTS OFF PORTS	<ol style="list-style-type: none"> Orifice too large High gas pressure Flue clogged Cold drafts 	<ol style="list-style-type: none"> Replace with correct orifice Check with gas utility company Clean flue and burner-locate source and correct Locate source and correct
BURNER FLAME TOO HIGH	<ol style="list-style-type: none"> Orifice too large 	<ol style="list-style-type: none"> Replace with correct orifice
FLAME BURNS AT ORIFICE	<ol style="list-style-type: none"> Thermostat not functioning properly Low gas pressure 	<ol style="list-style-type: none"> Replace thermostat Check with gas utility company
PILOT FLAME TOO SMALL	<ol style="list-style-type: none"> Pilot line or orifice clogged Low gas pressure 	<ol style="list-style-type: none"> Clean, locate source and correct Check with gas utility company
SMELLY WATER	<ol style="list-style-type: none"> Sulfides in the water 	<ol style="list-style-type: none"> Replace the anode with a special anode

STATUS LIGHT CODE TROUBLESHOOTING TABLE

Status Light Code

LED FLASH SEQUENCE	CONTROL STATUS	CORRECTIVE ACTION
Short flash once every four second	IDLE (No call for heat, no fault conditions)	
"Heartbeat", alternates bright/dim	Call for Heat (No fault conditions)	
One Flash, three second pause	Low Flame Signal (control continues to operate)	<p>Turn the power switch on the gas control valve to the "OFF" position and unplug the power cord from the power outlet.</p> <ol style="list-style-type: none"> 1. Check the incoming gas line pressure to ensure adequate supply to the water heater. If incoming gas supply pressure is adequate proceed to step 2. 2. Check all wiring connections and insure all harness and wires connections are seated firmly and provide proper electrical contact. If no connection problems are found proceed to step 3. Firmly seat any loose connections found. If any connections are found to be damaged consult the replacement parts list for the appropriate replacement. After any connection problems are fixed restart the water heater by following the lighting instructions on page 16. If the problem persists proceed to step 3. 3. Check condition of the base ring filter and flame trap. If they are clogged follow the instructions for cleaning on page 24. If parts are not clogged proceed to step 4. After cleaning follow instructions for lighting on page 16. If problem persists proceed to step 4. 4. Follow the instructions on page 23 to remove the burner assembly. Once the burner assembly has been removed inspect the manifold tube and burner, see figure 29, for any obstructions. If any clogs or obstructions are present clear them. Inspect the electrode/flame sense rod, see figure 35, for corrosion buildup, degradation, or damage. If there is evidence of any damage to the electrode/flame sense rod replace the igniter/pilot assembly. Follow the directions on page 25 to re-install the burner assembly into the combustion chamber. Follow the instructions for lighting on page 16. If the problem persists contact a certified service representative.
Two Flash, three second pause	End Switch Failed Closed	<p>Look at the top of water heater to see if the damper is open, see figure 20. If the damper is open insure there is no obstruction that would prevent the damper from closing. If there are any obstructions turn the power switch on the gas valve to the "OFF" position, remove the obstruction, if the damper closes turn the power switch on the gas valve to the "ON" position. If there are no obstructions present turn the power switch on the gas valve to the "OFF" position. Observe the damper to see if the damper closes. If the damper does not close unplug the power cord from the power outlet and proceed to step 1. If the damper closes turn the power switch on the gas valve to the "ON" position.</p> <ol style="list-style-type: none"> 1. Check all wiring connections to insure all harness and wire connections are seated firmly and provide proper electrical contact. If no connection problems are found replace the damper. Firmly seat any loose connections found. If any connections are found to be damaged consult the replacement parts list on page # for the appropriate replacement. After any connection problems are fixed restart the water heater by following the lighting instructions on page 16. If the problem persists replace the damper.
Three Flash, three second pause	End Switch Failed Open or TCO Limit Lockout	<p>Turn the power switch on the gas control valve to the "OFF" position and unplug the power cord from the power outlet.</p> <ol style="list-style-type: none"> 1. Attempt to depress the TCO door switch button, see figure # . If the TCO door switch button depresses follow the instructions for cleaning the filter and flame arrester on page 24. After cleaning is completed follow the lighting instructions on page #. If the TCO door switch button does not depress proceed to step 2. 2. Follow the lighting instructions on page 16. Observe the damper during initial startup. If there is a call for heat and the damper opens allow the unit to continue to perform and monitor any change in status. If there is a call for heat and the damper does not open proceed to step 3. 3. Check all wiring connections to insure all harness and wire connections are seated firmly and provide proper electrical contact. If no connection problems are found replace the damper. Firmly seat any loose connections found. If any connections are found to be damaged consult the replacement parts list on page 31-32 for the appropriate replacement. After any connection problems are fixed restart the water heater by following the lighting instructions on page 17. If the problem persists replace the damper.
Four Flash, three second pause	ECO Limit Lockout	<ol style="list-style-type: none"> 1. Turn the power switch on the gas control valve to the "OFF" position, wait 10-20 seconds then turn the power switch on the gas control valve to the "ON" position. If the problem persists replace the gas control valve.
Five Flash, three second pause	Flame Out of Sequence	<p>Turn the power switch on the gas control valve to the "OFF" position. Wait 10 minutes then follow the lighting instructions on page #. If the problem persists replace the gas control valve.</p>
Six-One Flash, three second pause	Soft Lockout - Retry Limit - Failed TFI	<p>Turn the power switch on the gas control valve to the "OFF" position and unplug the power cord from the power outlet.</p> <ol style="list-style-type: none"> 1. Check the incoming gas line pressure to ensure adequate supply to the water heater. If incoming gas supply pressure is adequate proceed to step 2. 2. Check all wiring connections and insure all harness and wires connections are seated firmly and provide proper electrical contact. If no connection problems are found proceed to step 3. Firmly seat any loose connections found. If any connections are found to be damaged consult the replacement parts list for the appropriate replacement. After any connection problems are fixed restart the water heater by following the lighting instructions on page #. If the problem persists proceed to step 3. 3. Check condition of the base ring filter and flame arrester. If they are clogged follow the instructions for cleaning on page 24. If parts are not clogged proceed to step 4. After cleaning follow instructions for lighting on page 16. If problem persists proceed to step 4.

STATUS LIGHT CODE TROUBLESHOOTING TABLE

Status Light Code

LED FLASH SEQUENCE	CONTROL STATUS	CORRECTIVE ACTION
Six-Two Flash, three second pause	Soft Lockout - Recycle Limit - Flame Lost - END Switch Fails	Turn the power switch on the gas control valve to the "OFF" position and unplug the power cord from the power outlet. 1. Check all wiring connections to insure all harness and wire connections are seated firmly and provide proper electrical contact. If no connection problems are found replace the damper. Firmly seat any loose connections found. If any connections are found to be damaged consult the replacement parts list on pages 31-32 for the appropriate replacement. After any connection problems are fixed restart the water heater by following the lighting instructions on page 16. If the problem persists replace the damper.
Six-Three Flash, three second pause	Soft Lockout - Recycle Limit - Flame Lost	Turn the power switch on the gas control valve to the "OFF" position and unplug the power cord from the power outlet. 1. Check the incoming gas line pressure to ensure adequate supply to the water heater. If incoming gas supply pressure is adequate proceed to step 2. 2. Check all wiring connections and insure all harness and wires connections are seated firmly and provide proper electrical contact. If no connection problems are found proceed to step 3. Firmly seat any loose connections found. If any connections are found to be damaged consult the replacement parts list for the appropriate replacement. After any connection problems are fixed restart the water heater by following the lighting instructions on page 16. If the problem persists proceed to step 3. 3. Check condition of the base ring filter and flame arrestor. If they are clogged follow the instructions for cleaning on page #. If parts are not clogged proceed to step 4. After cleaning follow instructions for lighting on page 16. If problem persists proceed to step 4. 4. Follow the instructions on page # to remove the burner assembly. Once the burner assembly has been removed inspect the manifold tube and burner, see figure 29, for any obstructions. If any clogs or obstructions are present clear them. Inspect the electrode/flame sense rod, see figure #, for corrosion buildup, degradation, or damage. If there is evidence of any damage to the electrode/flame sense rod replace the igniter/pilot assembly. Follow the directions on page 25 to re-install the burner assembly into the combustion chamber. Follow the instructions for lighting on page 16. If the problem persists contact a certified service representative.
Six-Four Flash, three second pause	Soft Lockout - Flame out of Sequence Sensed	Turn the power switch on the gas control valve to the "OFF" position and unplug the power cord from the power outlet. Wait 10 minutes then follow the lighting instructions on page 16. If the problem persists replace the gas control valve.
Seven Flash, three second pause	Flammable Vapor Sensor (FVS) Lockout	1. Do not touch any electrical switch, do not use any phone in the building and do not try to light any appliance. 2. Smell around the water heater to ensure there are no gas leaks at the gas control valve or in the supply gas line or for any other type of flammable vapors in the area. 3. Carefully inspect the area surrounding the water heater for any substances such as gasoline, paint, paint thinners, varnish, or cleaners that could emit flammable vapors. Remove anything that can potentially emit flammable vapors from the area and store it properly in a different location. 4. Contact a certified service representative for inspection.
Eight-One Flash, three second pause	Flammable Vapor Sensor (FVS) Fault Detected	Turn the power switch on the gas control valve to the "OFF" position, wait 10-20 seconds then turn the power switch on the gas control valve to the "ON" position. If the problem persists replace the gas valve.
Eight-Two Flash, three second pause	Temperature Sensor Fault Detected	Turn the power switch on the gas control valve to the "OFF" position, wait 10-20 seconds then turn the power switch on the gas control valve to the "ON" position. If the problem persists replace the gas valve.
Eight-Three Flash, three second pause	Electronic Fault Detected	Turn the power switch on the gas control valve to the "OFF" position, wait 10-20 seconds then turn the power switch on the gas control valve to the "ON" position. If the problem persists replace the gas valve.
Eight-Four Flash, three second pause	Gas Control Valve/Thermostat Fault Detected	Turn the power switch on the gas control valve to the "OFF" position, wait 10-20 seconds then turn the power switch on the gas control valve to the "ON" position. If the problem persists replace the gas valve.

SEQUENCE OF OPERATION CHART

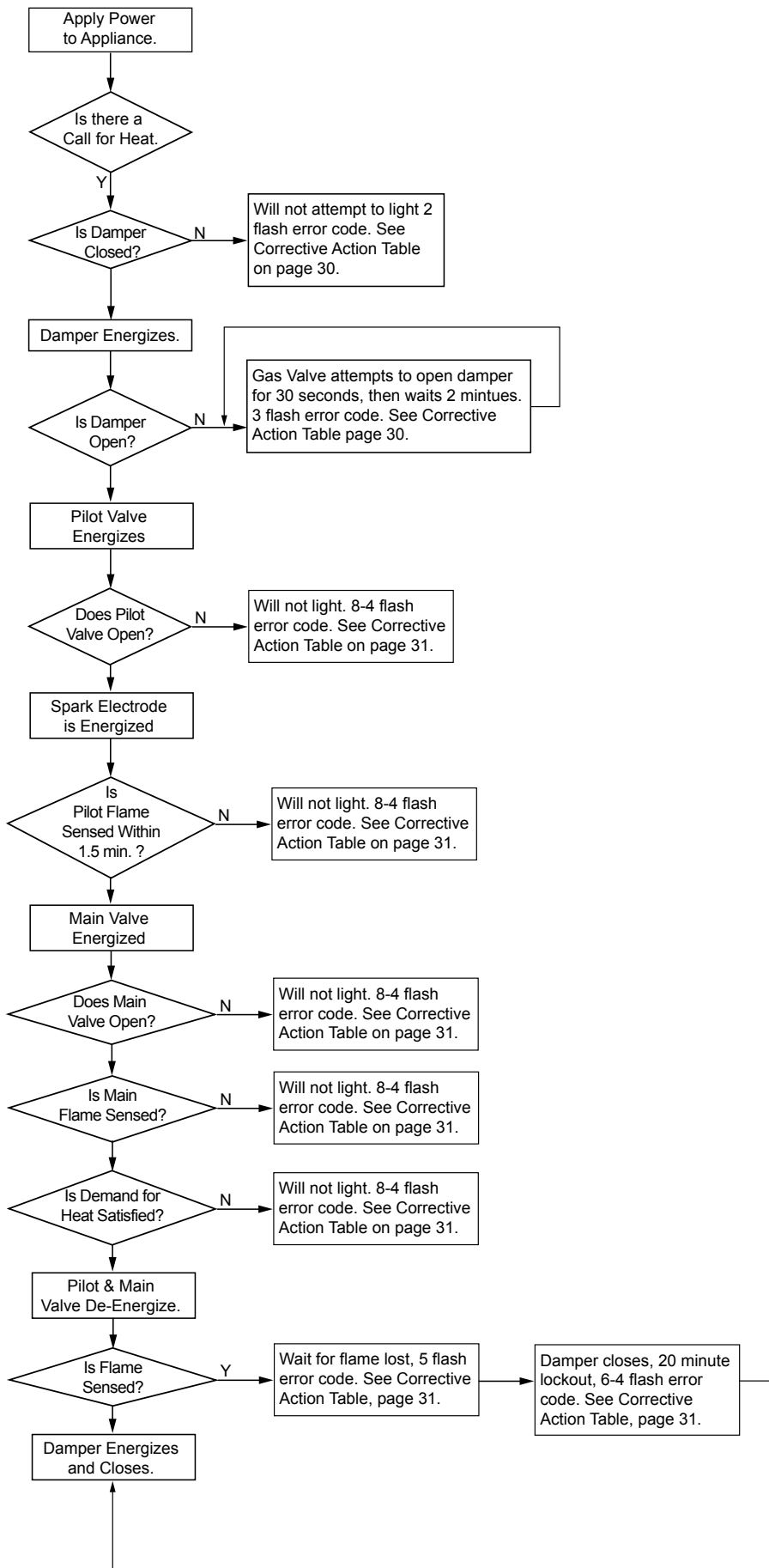

REPAIR PARTS ILLUSTRATION

When ordering repair parts always give the following information:

1. Model, serial, and product number
2. Type of gas
3. Item number
4. Parts description

Repair Parts List

Item No.	Parts Description
1	DRAFT HOOD
2	FLUE DAMPER
3	FLUE BAFFLE
4	HEAT TRAP (COLD) - SOME MODELS
5	HEAT TRAP (HOT) - SOME MODELS
6	COLD WATER DIP TUBE
7	ANODE ROD ▲
8	TEMPERATURE & PRESSURE RELIEF VALVE (LOCATED ON SIDE) ■
9	DRAIN VALVE
10	GAS CONTROL VALVE/THERMOSTAT ★
11	OUTER DOOR ★
12A*	STP (SPARK TO PILOT) PILOT ASSEMBLY KIT ★
12B*	STP (SPARK TO PILOT) PILOT ASSEMBLY KIT (L.P.) ★
13A*	BURNER (Natural Gas/Low Nox) ★
13B*	BURNER (L.P.) ★
14A*	BURNER ASSEMBLY ★
14B*	BURNER ASSEMBLY (L.P. Burner) ★
15*	MANIFOLD COMPONENT BLOCK
16*	MANIFOLD DOOR GASKET ★
17*	VIEWPORT ASSEMBLY
18**	TRANSFORMER ASSEMBLY KIT
19**	FV SENSOR KIT
20**	FV SENSOR KIT WITH BRACKET
21**	FV WIRE HARNESS
22**	MAIN WIRE HARNESS
23**	GAS CONTROL VALVE/THERMOSTAT CONTROL MODULE

*Pictured on next page.

** Not shown.

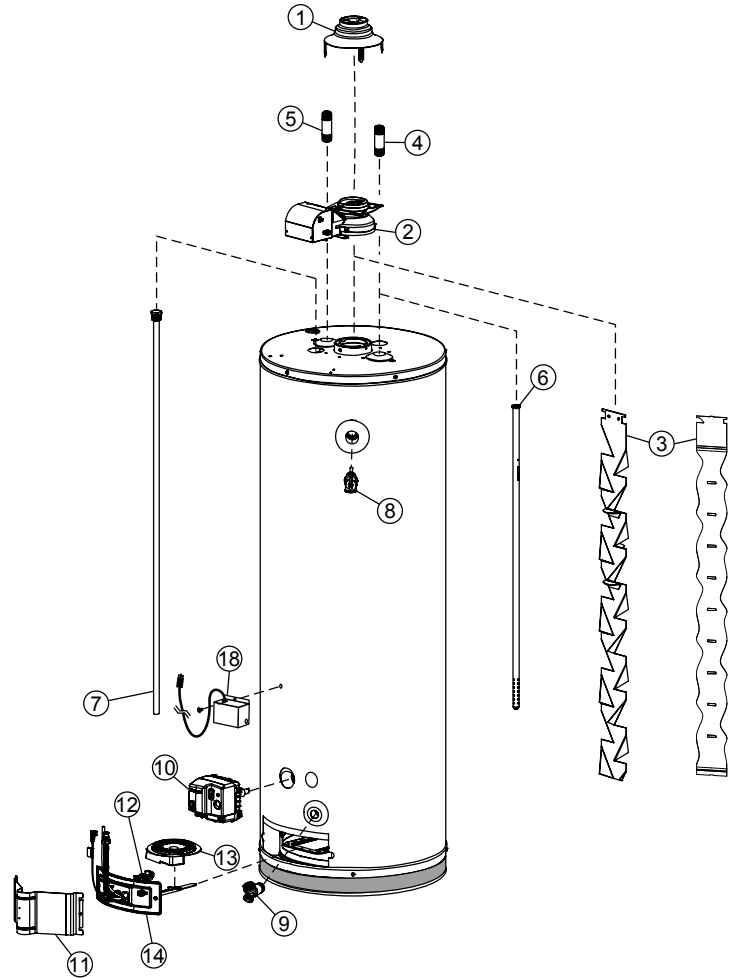

LEGEND

- ▲ Special anode rod (see page 21)
- Temperature and Pressure Relief Valve is required, but may not be factory installed
- ★ Unique: Flame Guard™ Safety System parts

Listed Parts Kits and Illustrations

Item 12A: Pilot/Igniter-Flame Sensor assembly kit, which contains the pilot, igniter-flame sensor, and retainer clip (Natural Gas)

Item 12B: Pilot/Igniter-Flame Sensor assembly kit, which contains the pilot, igniter-flame sensor, and retainer clip (L.P. Gas)

Item 13A: Burner (Natural Gas/L.P. Gas)

Item 13B: Burner (L.P. Gas)

Item 14A: Burner assembly which contains the manifold tube, gasket, door, pilot/igniter-flame sensor assembly, manifold component block with retainer clip, thermal switch, and pilot tube. (Natural Gas/Low Nox)

Item 14B: Burner assembly which contains the manifold tube, gasket, door, pilot/igniter-flame sensor assembly, manifold component block with retainer clip, thermal switch, and pilot tube. (L.P. Gas)

Item 15: Contains manifold component block and retainer clip

Item 16: Contains manifold door gasket

Item 17: Contains viewport

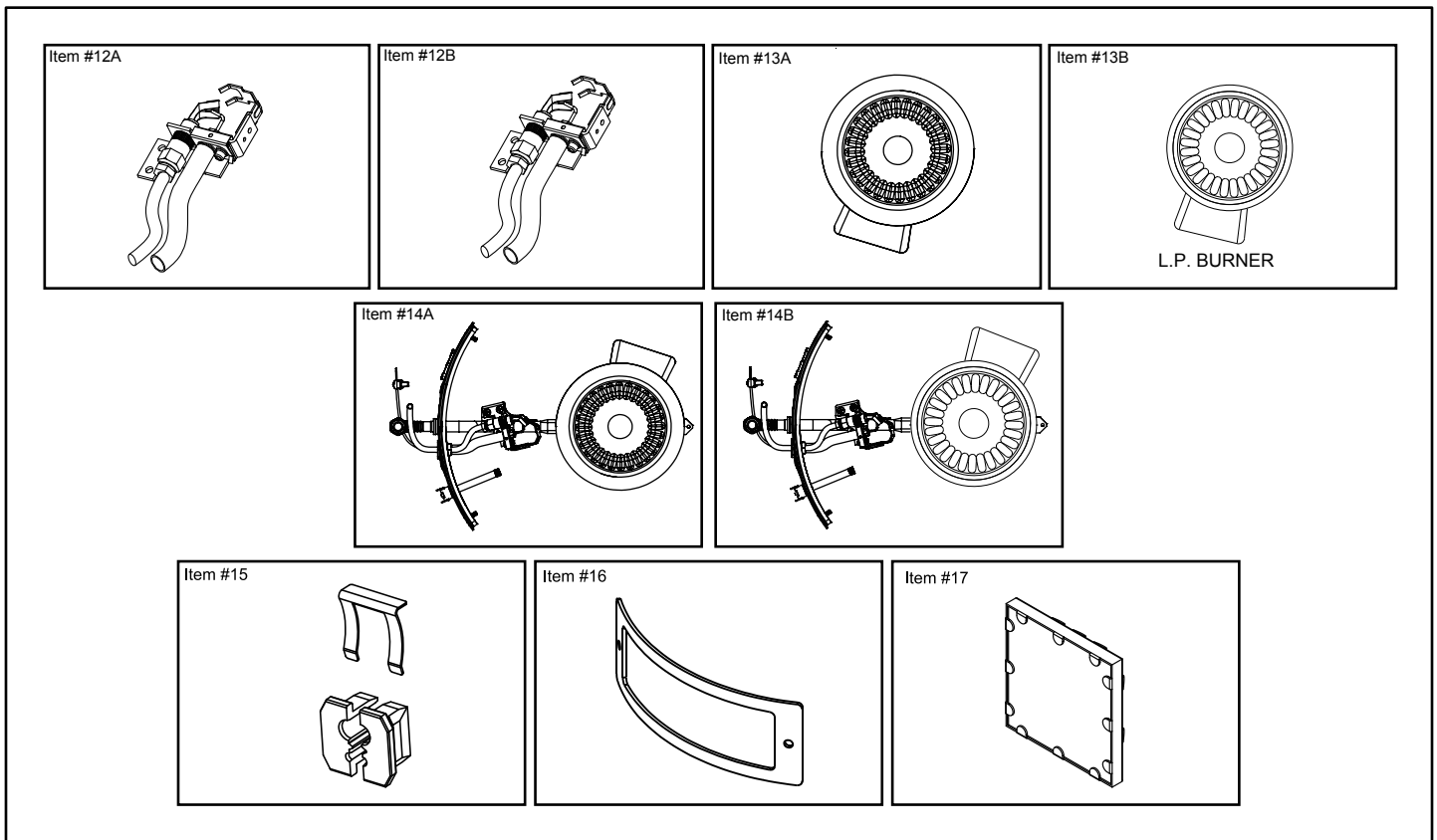

NOTES
