



# Commercial Gas Tankless Water Heater

## TANKLESS CONDENSING HIGH EFFICIENCY COMMERCIAL GAS

Ultra-Low NOx gas tankless water heaters with condensing technology featuring up to 0.95 Uniform Energy Factor (UEF) which lowers operating costs and is environmentally friendly.

### FEATURES:

**ULTRA-LOW NOX CONDENSING TECHNOLOGY PROVIDES UP TO 0.95 UNIFORM ENERGY FACTOR**

### DURABLE HEAT EXCHANGER

- Primary Heat Exchanger is constructed of Commercial-Grade Copper that is more resilient to erosion and is 25x better at heat transfer than stainless steel thus stabilizing outgoing water temperatures quicker
- Secondary Heat Exchanger is made of Type 316L Stainless Steel to protect against corrosion

**CONTINUOUS MAXIMUM FLOW RATES UP TO 10.0 GPM ENERGY STAR® QUALIFIED**

**AVAILABLE IN NATURAL GAS OR PROPANE (LP)**

**INDOOR MODEL - INCLUDES INTEGRATED TEMPERATURE CONTROLLER AND ADVANCED DIAGNOSTICS TO SIMPLIFY TROUBLESHOOTING**

**OUTDOOR MODEL - INCLUDES A WALL MOUNT TEMPERATURE REMOTE CONTROLLER AND ADVANCED DIAGNOSTICS TO SIMPLIFY TROUBLESHOOTING**

**FACTORY-INSTALLED POWER CORD INCLUDED FOR INDOOR MODELS**

**EASY-LINK UP TO 4 UNITS (CT-199 MODELS ONLY)**

- With no additional parts or accessories needed

**MULTI-LINK UP TO 20 UNITS**

**COMMON VENT UP TO 8 UNITS**

**COMPLIES WITH LEAD FREE STANDARDS**

### SAFETY FEATURES:

- Air-Fuel Ratio (AFR) Sensor
- Exhaust & Water Temperature Safety Control
- Overheat Cut-Off Fuse

**INTERNAL FREEZE PROTECTION SYSTEM**

### POWER DIRECT VENT DESIGN

- Exhaust, 3" PVC Venting up to 70 feet or 4" PVC Venting up to 100 feet
- Provides flexible venting with PVC, CPVC, or ABS Pipe for Intake and Exhaust (solid core only). Canadian Installations Require ULCS636 Listed PVC or CPVC Pipe for Venting.
- Category III or IV venting can be used

### ACCESSORIES

- Pipe Cover
- Neutralizer Kit
- Isolation Valve Kits
- Concentric Termination

### WARRANTY

- 6-year limited warranty on heat exchanger in commercial applications
- 5-year limited warranty on all parts

### INDOOR MODEL CT-199



### OUTDOOR MODEL CT-199



ANSI Z21.10.3 CSA 4.3



# Commercial Gas Tankless Water Heater

| Model Number          | Type    | Gas Consumption Input |               | Inlet Gas Pressure |                  | UEF  | Maximum GPM* | Hot/Cold Connections | Gas Connection | Dimensions in Inches |        |        | Approx Shipping Weight (lbs) |
|-----------------------|---------|-----------------------|---------------|--------------------|------------------|------|--------------|----------------------|----------------|----------------------|--------|--------|------------------------------|
|                       |         | Minimum BTU/H         | Maximum BTU/H | Minimum in. W.C.   | Maximum in. W.C. |      |              |                      |                | Height               | Width  | Depth  |                              |
| <b>Indoor Models</b>  |         |                       |               |                    |                  |      |              |                      |                |                      |        |        |                              |
| <b>MCT-199I-N</b>     | Natural | 15,000                | 199,000       | 4.0                | 10.5             | 0.93 | 10           | 3/4" NPT             | 3/4" NPT       | 23-5/8               | 17-3/4 | 11-1/4 | 71                           |
| <b>MCT-199I-P</b>     | Propane | 13,000                | 199,000       | 8.0                | 14.0             | 0.93 | 10           | 3/4" NPT             | 3/4" NPT       | 23-5/8               | 17-3/4 | 11-1/4 | 71                           |
| <b>Outdoor Models</b> |         |                       |               |                    |                  |      |              |                      |                |                      |        |        |                              |
| <b>MCT-199O-N</b>     | Natural | 15,000                | 199,000       | 4.0                | 10.5             | 0.95 | 10           | 3/4" NPT             | 3/4" NPT       | 23-5/8               | 17-3/4 | 11-1/4 | 69                           |
| <b>MCT-199O-P</b>     | Propane | 13,000                | 199,000       | 8.0                | 14.0             | 0.95 | 10           | 3/4" NPT             | 3/4" NPT       | 23-5/8               | 17-3/4 | 11-1/4 | 69                           |

All dimensions are in inches.

15-150 psi Water Pressure. 40 psi or above is recommended for maximum flow.

\*Current numbers based on factory testing; 0.4 GPM required for continuous fire after initial ignition.

Indoor models are certified from sea level to 10,100 ft. elevations.

Outdoor models are certified from sea level to 6,000 ft. elevation.

The manufacturer reserves the right to discontinue, or change at any time, specifications or designs without notice and without incurring obligation.



# Commercial Gas Tankless Water Heater

Flow Rate vs. Temperature Rise

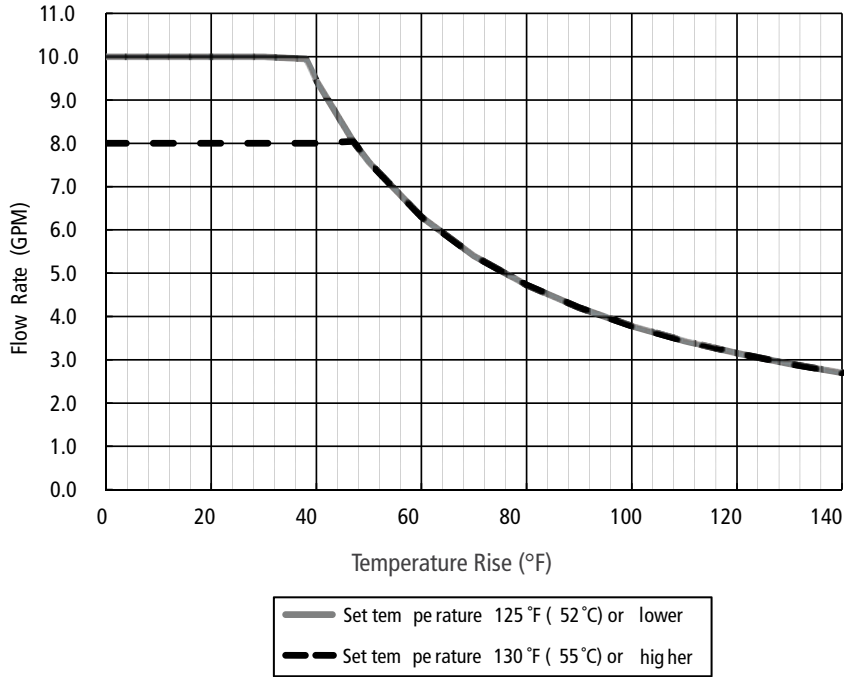

Pressure Loss

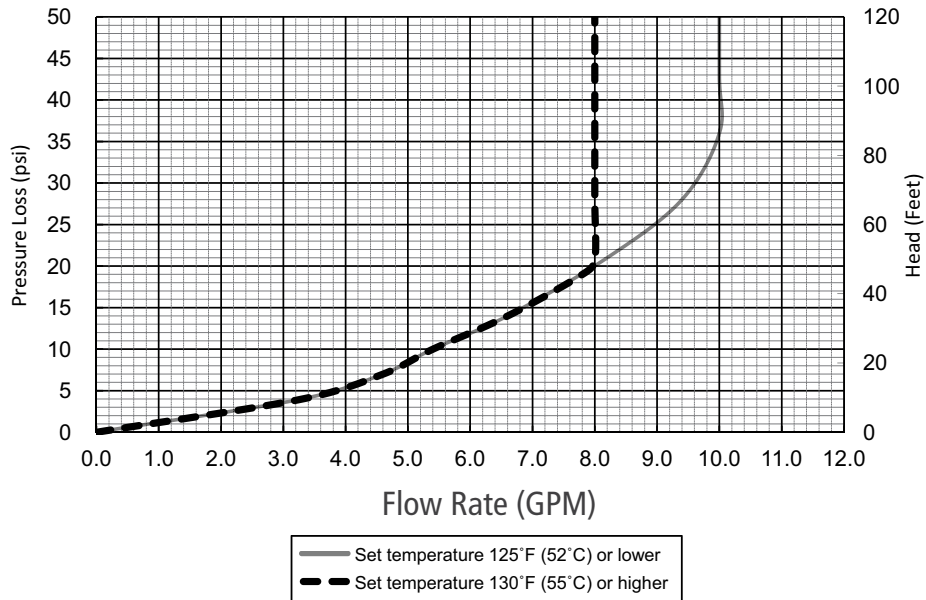

## INDOOR MODEL

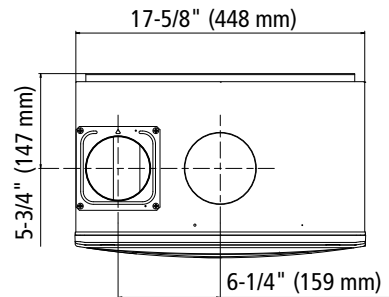
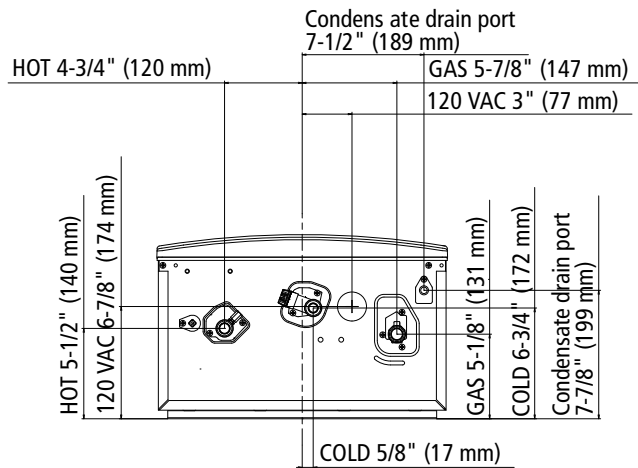
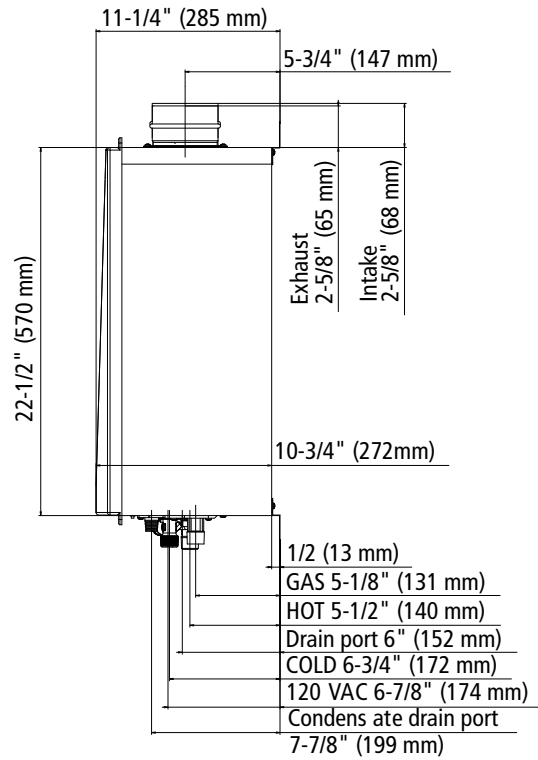
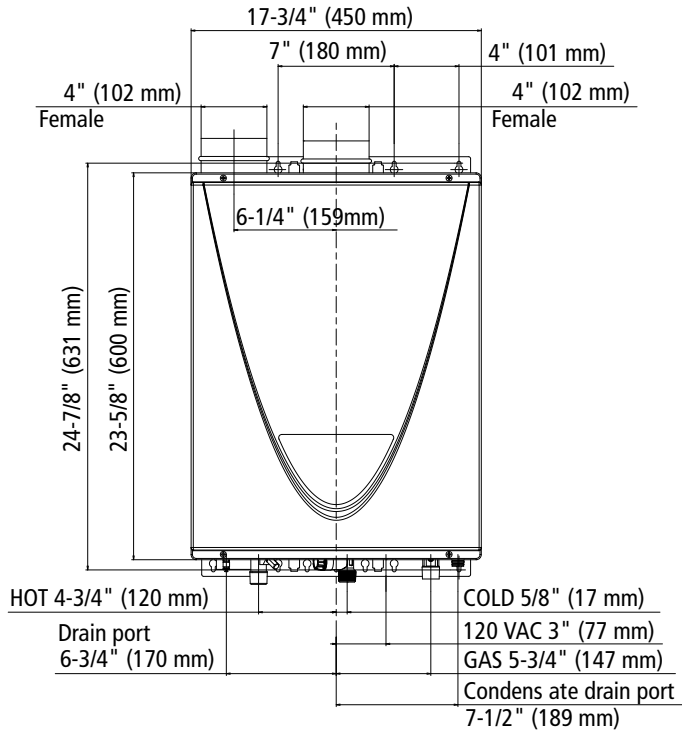



# Commercial Gas Tankless Water Heater

## OUTDOOR MODEL

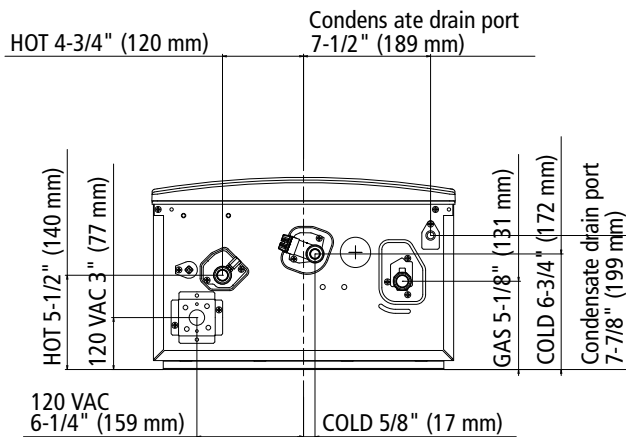
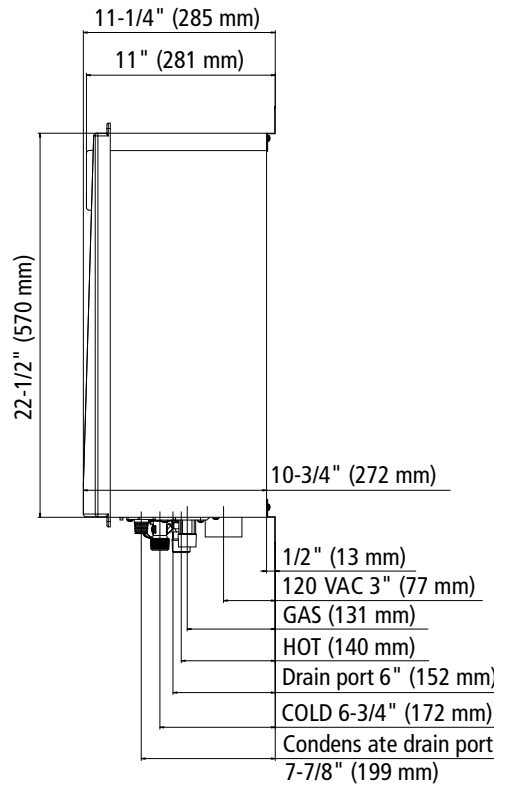
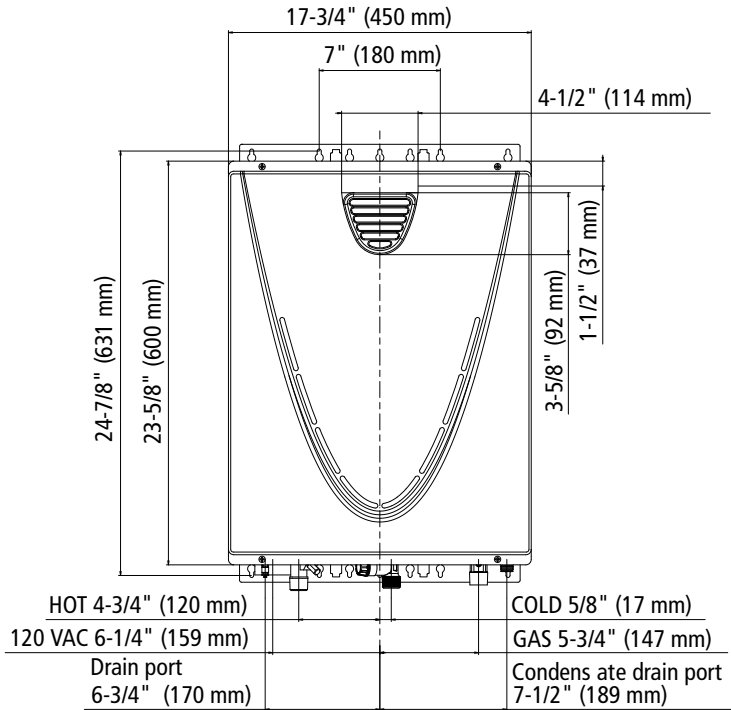



## Commercial Gas Tankless Water Heater

### TANKLESS CONDENSING HIGH EFFICIENCY SPECIFICATIONS

The fully modulating, on-demand, condensing gas fired tankless water heater(s) shall be American model CT-199, having a maximum input rating of 199,000 Btu/h and available in NG or LP. The heater shall have  $\frac{3}{4}$  in. male NPT water and gas connections. The inlet gas supply pressures shall be 4.0 in. WC (min.) up to 10.5 in. WC (max) for NG and 8.0 in. WC (min.) up to 14 in. WC (max.) for LP. The indoor heater(s) shall incorporate an integrated temperature controller that will provide diagnostic information, fault history, and heater set temperature. The outdoor heater(s) shall be factory supplied with a temperature remote, 100112572, that can be installed up to 400 ft. from the heater using 18 gauge (minimum) control wire. The temperature remote shall provide diagnostic information, fault history, and heater set temperature. The heater(s) shall operate using 120 V / 60 Hz power source. The indoor heater(s) will incorporate a factory installed power cord.

The indoor heater(s) shall be vented with 3" or 4" diameter schedule 40 PVC, CPVC, ABS, or Category IV vent pipe with a length not to exceed 70 ft. (equivalent) for 3" vent or 100 ft. (equivalent) for 4" vent, terminating horizontally or vertically. The intake pipe may use material such as PVC, ABS, aluminum, or Category IV pipe and cannot exceed 70 ft. (equivalent) for 3" vent or 100 ft. (equivalent) for 4" vent. The outdoor heater(s) shall be constructed with an integral exhaust vent on the front of the heater.

The water heater(s) shall use a commercial-grade copper, fin tube primary heat exchanger with quick release brass or bronze waterways. The secondary heat exchanger shall be constructed from stainless steel 316L. The heater(s) shall be controlled by an on-board solid-state printed circuit board which uses the following factory installed components: thermistors to monitor water temperature and exhaust temperature; a flow sensor to measure flow rate; a flame sensor to monitor combustion; an Air-Fuel Ratio Rod to measure and adjust air input in order to maintain optimal combustion efficiency. The heater also consists of in-line fusing and surge absorbers for electrical surge protection, an electronic spark igniter, aluminized stainless steel burners, hi-limit temperature switches to monitor water and exhaust temperatures, modulating gas valve, dual freeze protection that will automatically fire the heater (indoor model only) and use heating blocks to protect the heat exchanger, and an overheat cutoff fuse.

The heater(s) can manifold to Easy-Link up to 4 heaters to provide additional capacity. The Easy-Link controls shall be built onto the on-board solid-state printed circuit board and does not require external controls. The linking control wire shall be supplied with the heater. The heater(s) can use a Multi-Unit controller, 100112691, to manifold 5-20 heaters. The Easy-Link and Multi-Unit Controller shall modulate the system for the most efficient performance. The Easy-Link and Multi-Unit Controller shall rotate the priority heater every 12 hours of operation time or 100 starts for balanced duty/cycle operation.

The heater models are design certified by CSA according to ANSI Z21.10.3 • CSA 4.3, approved for sale in the United States, ENERGY STAR® qualified, has a minimum uniform energy factor of 0.93, meets the energy efficiency requirements of the U. S. Department of Energy and ASHRAE 90.1, complies with SCAQMD Rule 1146.2 and other air quality districts with similar requirements for low NOx emissions of 14 ng/J or 20 ppm, and shall be certified to NSF 5 standards.

For technical information call (800) 999-9515. American Water Heaters reserves the right to make product changes or improvements without prior notice.